

# Single Output Power Supply OZ-060 series

## Various outputs (+3.3V,+5V,+12V,+15V, and +24V) with 60W lined up



**RoHS  
Directive**

**Single Output**  
Continuous Max. **39.6W**  
~60W  
Peak **—**

Structure and In/Out connector	Model	Output voltage	Output current	Output power	Stock	Standard price (Before Tax)
Open frame type/ Nylon connector	OZ-060-3R3-J00	+3.3V	12A	39.6W	Standard Stock	¥5,000
	OZ-060-5-J00	+5V	12A	60W	Standard Stock	¥5,000
	OZ-060-12-J00	+12V	5A	60W	Standard Stock	¥5,000
	OZ-060-15-J00	+15V	4A	60W	Standard Stock	¥5,000
	OZ-060-24-J00	+24V	2.5A	60W	Standard Stock	¥5,000
Structure	Description	Stock	Standard price (Before Tax)			
W/T Chassis	'C' is added after Open frame model name (Ex.OZ-060-3R3-J00-C)	Standard Stock	Open frame type price + ¥550			
W/T Chassis and Cover	'K' is added after Open frame model name (Ex.OZ-060-3R3-J00-K)	Standard Stock	Open frame type price + ¥950			
Input/Output connector	Model name	Stock	Standard price (Before Tax)			
European connector type	'E' from 'J' of nylon connector model (Ex. OZ-060-3R3-E00)	Standard Stock	Nylon connector type price + ¥490			

### Model name coding

OZ - 060 - \*\* - \*\* 0 - \*

① ② ③ ④ ⑤ ⑥ ⑦

- ① Series name
- ② Output power
- ③ 3R3: +3.3V output
- 5: +5V output
- 12: +12V output
- 15: +15V output
- 24: +24V output
- ④ Input/Output connector
- J: Nylon connector
- E: European connector
- ⑤ Backup function NOT available
- ⑥ Optional specification NOT available
- ⑦ Blank: Open frame type
- K: W/T Chassis and Cover

### Features

- Double sided PWBs with through holes suitable for Industrial use (Competitors mainly adopt Single sided PWBs).
- Equipped with a variable resistor to adjust output voltage
- For Input/Output connectors, Nylon connector or European connector is selectable.
- Safety standards are acquired (UL60950-1, CSA60950-1, EN60950-1, and EN50178)
- High efficiency with synchronous rectifying system except 24V output model

Refer to C-B1 "Product page guideline" for icons.

Safety standard	UL	CSA	EN	CE	CCC
Reliability grade	HFA	FA	HOA	OA	

### Function

TTL	PFC	RoHS指令 RoHS Directive
-----	-----	--------------------------

### Input

AC input	85V to 264V (Worldwide range)
----------	-------------------------------

### Dimension

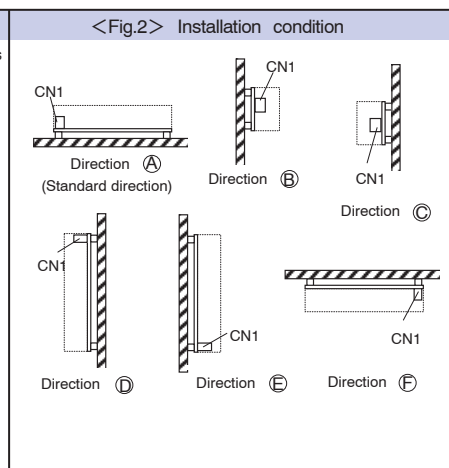
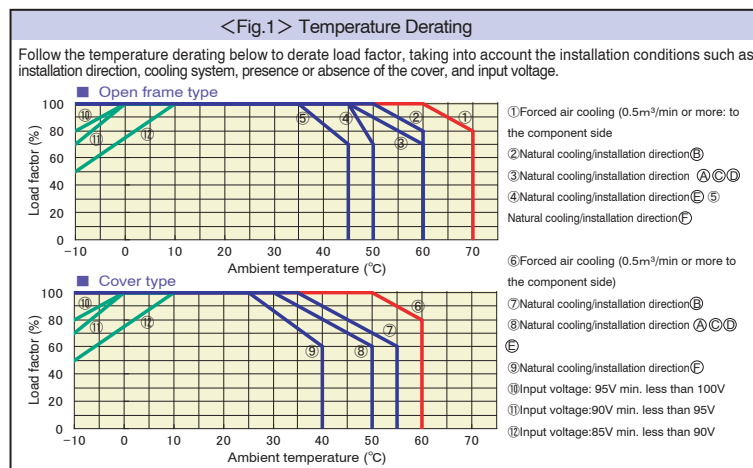
W × H × D (mm)	W/O Chassis and Cover	55 × 32 × 195
	W/T Chassis and Cover	65 × 42 × 225

Page	Items	Specification	Measurements, etc.					
AC Input	D-6(1) Rated voltage	AC100-240V (AC85-264V) <a href="#">Data on Fig 9-10,34-35,60-61,85-86, and 110-111</a>	Worldwide range					
	D-6(2) Frequency	50/60Hz	Frequency range: 47-63Hz					
	D-6(3) Efficiency	100V input	74% typ(+3.3V),77% typ(+5V),80% typ(+12V),82% typ(+15V),83% typ(+24V) <a href="#">Data on Fig 3,28, 54,79, and 104</a>	at Rated output				
		240V input	75% typ(+3.3V),79% typ(+5V),82% typ(+12V),82% typ(+15V),83% typ(+24V)					
	D-6(4) Power factor	<a href="#">Data on Fig 4, 29, 55, 80, and 105</a>						
	D-6(5) Inrush current	25A typ(AC100V),50A typ(AC200V) <a href="#">Data on Fig 5,30,56,81, and 106</a>		at Rated load and Cold start (25°C)				
D-6(6) Input current	100V input	0.85A typ(+3.3V),1.23A typ(+5V),1.18A typ(+12V),1.15A typ(+15V),1.14A typ(+24V)	at Rated output					
	240V input	0.48A typ(+3.3V),0.67A typ(+5V),0.64A typ(+12V),0.64A typ(+15V),0.63A typ(+24V)						
Output	Model	OZ-060-3R3    OZ-060-5    OZ-060-12    OZ-060-15    OZ-060-24						
	Rated voltage	+3.3V    +5V    +12V    +15V    +24V						
	Rated current	12A    12A    5A    4A    2.5A						
	D-6(8) Max. current/Power	12A    12A    5A    4A    2.5A						
		39.6W    60W    60W    60W    60W						
	D-6(10) Min. load	0A    0A    0A    0A    0A						
	— Voltage adjustable range (%)	±10					at Rated input with 50% load	
	D-6 (11)-⑧ Total voltage regulation (%)	±165 max.	±250 max.	±600 max.	±750 max.	±1200 max.	Sum of fluctuation by Temp., Input and Load	
	D-7(12) Max. ripple voltage (mVp-p)	0-50°C	80 max.	80 max.	120 max.	120 max.	120 max.	To measure on the test board with a capacitor (47uF) with 20MHz oscilloscope. The test board shall be away from load wires and within 150 mm from the output terminals. <a href="#">Data on Fig 26,51, 77,102, and 127</a>
		-10-0°C	140 max.	140 max.	160 max.	160 max.	160 max.	
D-7(12) Max. spike voltage (mVp-p)	0-50°C	120 max.	120 max.	150 max.	150 max.	150 max.		
	-10-0°C	160 max.	160 max.	180 max.	180 max.	180 max.		
Protection	D-7(13) Overcurrent protection	OCP point (A)	12.6 min.	12.6 min.	5.25 min.	4.2 min.	2.65 min.	at the load when output voltage falls down by 10%.
		Method	Hold-down current limiting					
	Recovery	Automatic recovery						
	D-7(14) Overvoltage Protection	OVP point (V)	4-6	Operation point is 115% to 140% of rated voltage.				
	Method	Output latch lock (See ※ below)						
		Recovery	Reclosing of Input					
Environment	D-7(16) Operating temperature and Humidity	-10-60°C*/20-90%					* See <Fig.1> Temperature derating below. No condensation	
	D-7(17) Storage Temp. and Humidity	-20-75°C/10-95%					No condensation	
	D-7(18) Vibration	To endure the acceleration of 2G with vibration frequency of 10 to 55Hz for 10 sweep cycles in each X-, Y-, and Z-direction.					To follow JIS-C-60068-2-6 at no operation	
	D-7(19) Mechanical strength (surface drooping)	Lift one bottom edge of the unit up to 50mm high with the opposite edge placed on the test bench, and let it fall. Repeat 3 times for each of four bottom edges, and no malfunction shall be observed.					To follow JIS-C-60068-2-31 at no operation	
Insulation	D-7(20) Dielectric strength	AC 1500V for 1 min. between AC input and DC output/FG					Cut-off current: 20mA	
	D-7(21) Insulation resistance	50MΩ min. between AC input and DC output/FG, and between DC output and FG.					At DC500V	
	D-7(22) Leakage current	0.5mA max. at AC 100V, and 1mA max. at AC 200V <a href="#">Data on Fig.6,31,57,82, and 107</a>					YEW.TYPE3226 (1kΩ) or equivalent	
EMC	D-7(23) Line noise immunity	±1000V (Pulse width: 100/1000ns, Repeated cycle: 30 to 100Hz, Normal mode/Common mode with Positive/Negative polarity for 1 minute.)					To measure with IIS-410. There shall be no DC-factor fluctuation of output and malfunction.	
	D-7(24) Electrostatic discharge	EN61000-4-2 Compliant						
	D-7(25) Radioactive radio frequency electromagnetic field	EN61000-4-3 Compliant						
	D-7(26) Fast Transient Burst	EN61000-4-4 Compliant						
	D-7(27) Lightning	EN61000-4-5 Compliant						
	D-7(28) Conductive radio frequency electromagnetic field	EN61000-4-6 Compliant						
	D-7(29) Power source frequency magnetic field Immunity	EN61000-4-8 Compliant						
	D-8(30) Voltage dips/Fluctuation	EN61000-4-11 Compliant <a href="#">Data on Fig.19-20,44-45,70-71,95-96, and 120-121</a>						
	D-8(31) Conducted Emission	VCCI-B, FCC-B, EN55022-B, and CISPR22-8 Compliant					Connect a metal spacer of 8mm in height between FG land of PSU board mounting hole on the PCB solder side and an iron plate to measure the PSU single body. The iron plate shall be the same size as the PSU board and 1mm thick.	
	Others	D-8(1)-6 Safety standard	UL60950-1, CSA60950-1 (c-UL), EN60950-1, EN50178, CE Marking (Low voltage directive) the Electrical Appliance and Material Safety Law (section 2) compliant					
D-8(34) Cooling system		Natural air cooling						
D-8(35) Output GND grounding		Capacitor earthing						
D-8(38) Output hold-up time		AC turn-off → 90% of rated voltage: 20ms min at AC100V, 100ms min. at AC200V. <a href="#">Data on Fig.17,42,68,93, and 118</a>					at Rated output	
F-3 Reliability Grade		FA (Industrial use appliance to use double-sided PWBs with through holes)					To follow our Standard	
D-8(41) MTBF		200,000 H min					To follow EIAJ RCR-9102	
— Weight		300g typical W/O Chassis and Cover						
F-3 Warranty		Three years after delivery. However, if any faults belong to us, the defective unit shall be repaired or replaced at our cost.					Except causes generated by operation out of this specification	

Computer Power Supply - BRAIN

Control & Mechanism System Power Supply - LIMBS

- B. SELECTION GUIDE
- B. PRODUCT PAGE GUIDELINE
- B. NONSTOP POWER SUPPLY
- B. AC+DC DUAL-INPUT PSU
- B. GENERAL PURPOSE PC PSU
- B. GENERAL PURPOSE REDUNDANT PSU
- B. OPTIONS
- C. SELECTION GUIDE
- C. PRODUCT PAGE GUIDELINE
- C. AC-DC SINGLE OUTPUT NONSTOP PSU
- C. AC-DC MULTI-OUTPUT NONSTOP PSU
- C. AC-DC SINGLE OUTPUT POWER SUPPLY
- C. AC-DC MULTI-OUTPUT POWER SUPPLY
- C. DC-DC CONVERTER
- C. OPTIONS
- D. TECHNICAL DICTIONARY
- E. COMPANY PROFILE
- F. BUSINESS MANUAL
- G. INDEX



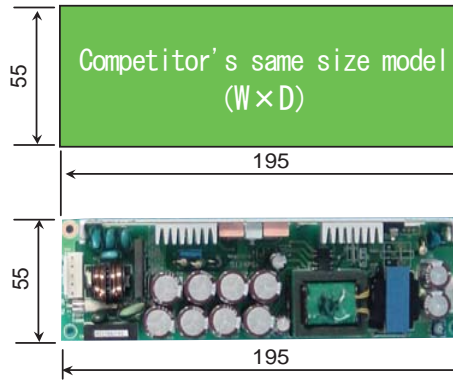
※ **Output latch lock**  
 When overvoltage occurs due to malfunction of the unit, output shuts down by stopping switching operation of the primary circuit. This status lasts as long as AC input exists.  
 For recovery, remove the cause and turn on AC input again.

**Higher efficiency!  
with synchronous rectifying  
circuit**

Synchronous rectifying FET



**High power !**



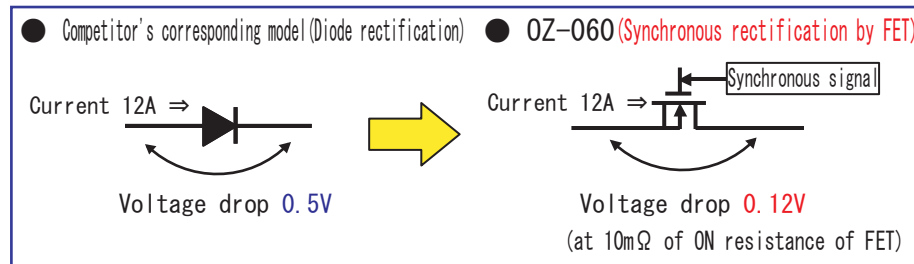
Competitor's 50W  
(5V output model)



Nipron's **60W**  
(5V output model)

● Adoption of synchronous rectification ⇒ High efficiency

(Except 24V output model)



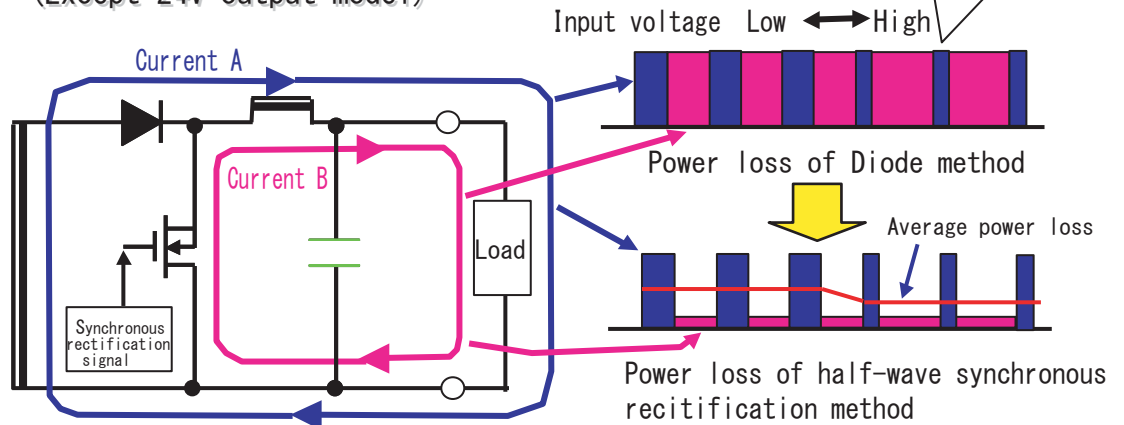
Power loss = 0.5V × 12A = 6W

Big heat of diode ⇒ Poor efficiency  
⇒ Heat sink is required.

Power loss = 0.12V × 12A = 1.44W

Very few heat of FET ⇒ Higher efficiency  
⇒ No Heat sink

● Adoption of half-wave rectification ⇒ High efficiency  
(Except 24V output model)

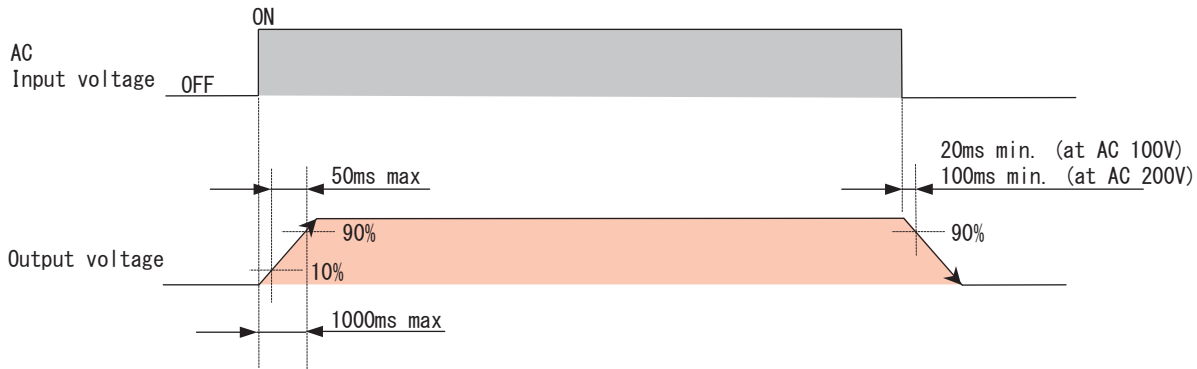


※ Synchronous rectification only for the period in which current B flows ⇒  
The higher input voltage, the higher efficiency!

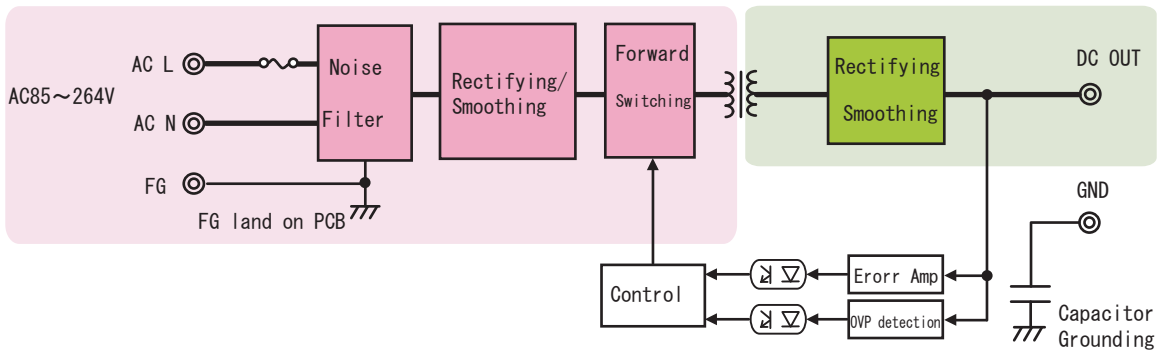
● Efficiency measurement data of OZ-060

	100V input	200V input
OZ-060-3R3 (3.3V 12A)	74.1%	76.2%
OZ-060-5 (5V 12A)	77.0%	79.7%
OZ-060-12 (12V 5A)	80.5%	83.3%
OZ-060-15 (15V 4A)	81.7%	83.4%
OZ-060-24 (24V 2.5A)	82.6%	84.3%

## Sequence Timing Chart



## Block Diagram



## ● Double sided PWBs with through holes adopted! (Single sided PWBs at competitors)

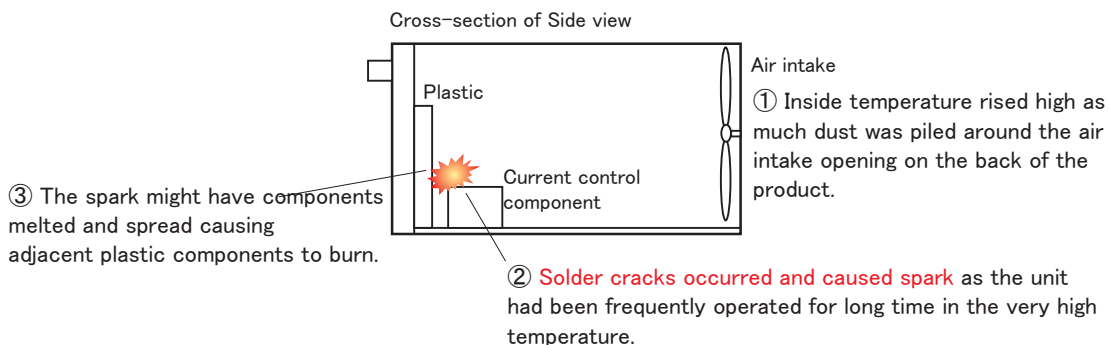
- No solder cracks even with Lead free soldering.

### Trouble case

Smoke and Fire from microwave ovens of M company in May, 2007!

⇒ Major recall from the market

Cause of Smoke and Fire



A. UPDATE

B. A. SELECTION GUIDE

B. B. PRODUCT PAGE GUIDELINE

B. C. NONSTOP POWER SUPPLY

B. D. AC+DC DUAL-INPUT PSU

B. E. GENERAL PURPOSE PC PSU

B. F. GENERAL PURPOSE REDUNDANT PSU

B. G. OPTIONS

Computer Power Supply - BRAIN

C. A. SELECTION GUIDE

C. B. PRODUCT PAGE GUIDELINE

C. C. AC-DC SINGLE OUTPUT NONSTOP PSU

C. D. AC-DC MULTI-OUTPUT NONSTOP PSU

C. E. AC-DC SINGLE OUTPUT POWER SUPPLY

C. F. AC-DC MULTI-OUTPUT POWER SUPPLY

C. G. DC-DC CONVERTER

C. H. OPTIONS

Control & Mechanism System Power Supply - LIMBS

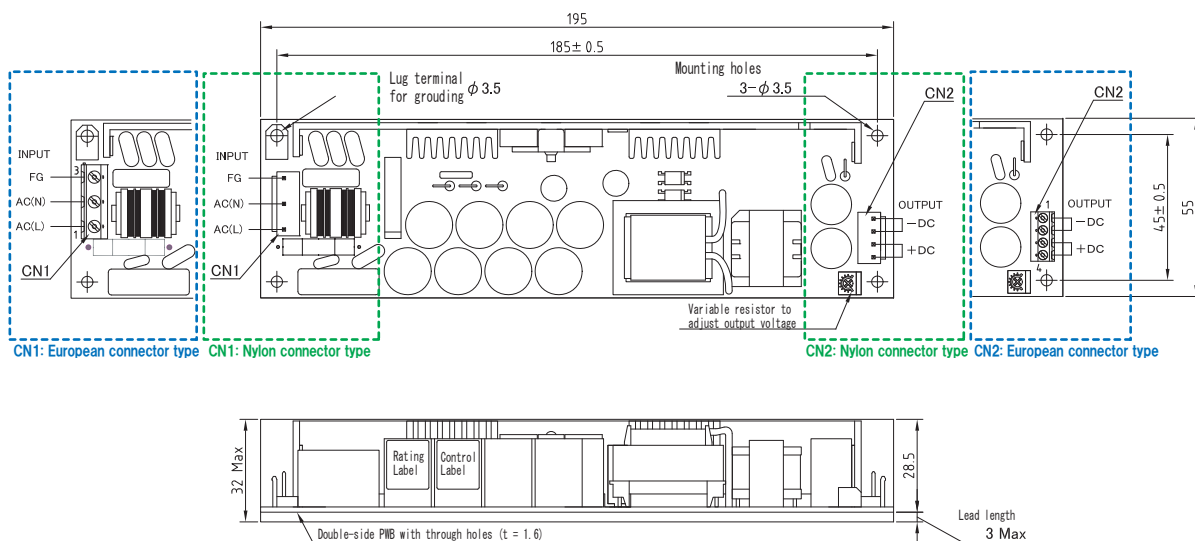
D. TECHNICAL DICTIONARY

E. COMPANY PROFILE

F. BUSINESS MANUAL

G. INDEX

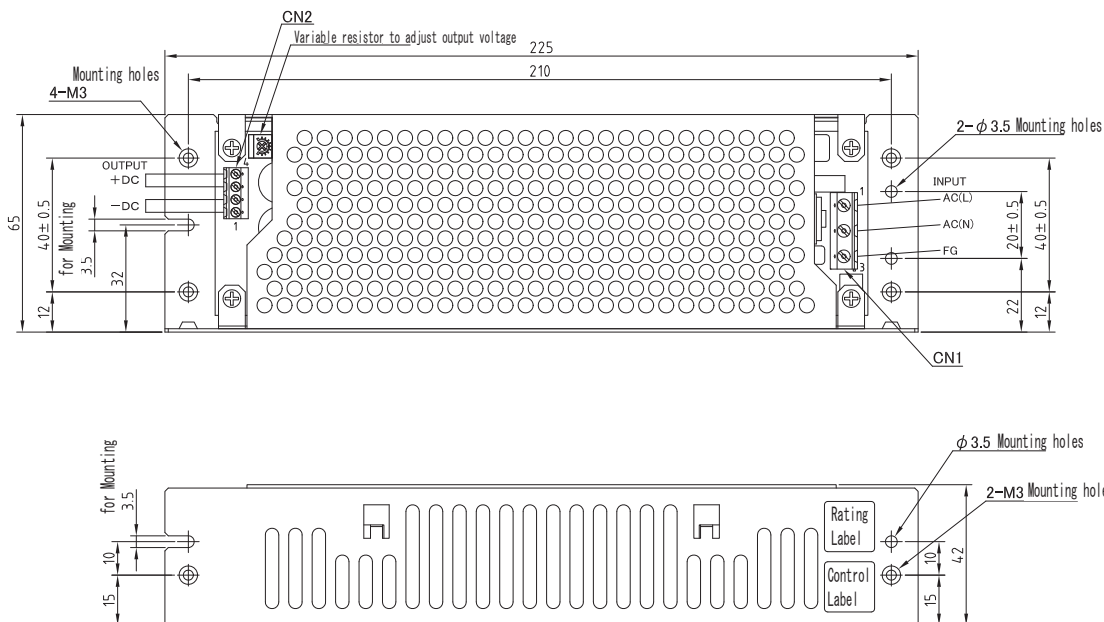
■ Open frame model



■ Connector pin allocation

Nylon connector type			European connector type		
<b>CN1: INPUT</b>			* Applicable housing VHR-5N (JST)		
PIN No.	FUNCTION	CONNECTOR TYPE	* Applicable terminal Reel:SVH-21T-P1.1 Bulk:BVH-21T-P1.1		
1	AC(L)	B3P5-VH (JST)			
2	AC(N)				
3	AC(N)				
4	FG				
<b>CN2: OUTPUT</b>			* Applicable housing VHR-4N (JST)		
PIN No.	FUNCTION	CONNECTOR TYPE	* Applicable terminal Reel:SVH-21T-P1.1 Bulk:BVH-21T-P1.1		
1	-DC	B4P-VH (JST)			
2	-DC				
3	+DC				
4	+DC				
			* Current per pin shall be 6A or less for CN2.		
<b>CN1: INPUT</b>			* Applicable housing GMKDSN 1.5/3-7.62 (PHOENIX)		
PIN No.	FUNCTION	CONNECTOR TYPE	* Applicable wire gauge: UL 1007 AWG#26 to 16 * Stripped length: 5mm		
1	AC(L)				
2	AC(N)				
3	FG				
<b>CN2: OUTPUT</b>			* Applicable housing MKDS 1/4-3.81 (PHOENIX)		
PIN No.	FUNCTION	CONNECTOR TYPE	* Applicable wire gauge: UL 1007 AWG#26 to 16 * Stripped length: 5mm		
1	-DC				
2	-DC				
3	+DC				
4	+DC				
			* Current per pin shall be 6A or less for CN2.		

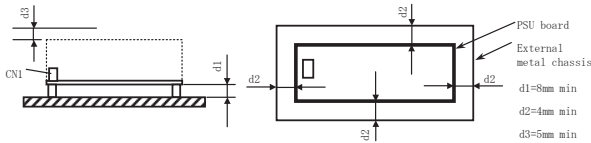
■ Model with Chassis and Cover



Dimensional tolerance shall be ±1 unless otherwise specified.

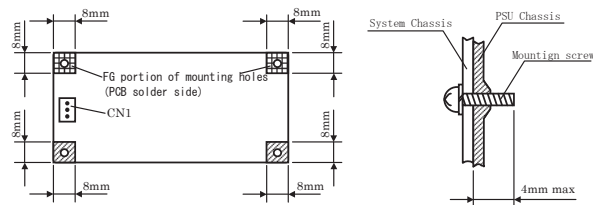
## Power supply Installation Dimension

- Keep d1, d2, and d3 below to meet the safety standard for Insulation and dielectric strength.
- Arrange the installation direction of the unit to secure the natural air convection and ventilation so that the ambient temperature rise around the unit is prevented.



## Power supply Installation And Grounding

- For single PSU board use, fix all four mounting holes with 3mm diameter screws.
- Metal parts such as PSU mounting screws shall not exceed the hatched area shown below.
- For models with Chassis and Cover, dimension of PSU mounting screw shall not exceed the size shown in the drawing below.
- FG terminal of CN1 or FG portion on the solder side of the PCB shall be securely connected to the safety earth of whole system using metal part such as metal spacer (washer). When applying for a safety standard, make sure to connect FG terminal of CN1 to the safety GND terminal of the system chassis.



## Regarding Series And Parallel Connection

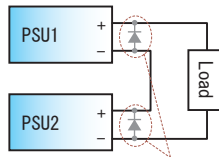
### Series connection

- Series connection shown on the right is available.
- Series connection between different output voltages is available, such as 12V and 24V.

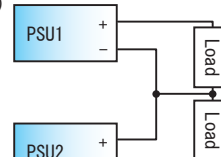
Note: In the case that different voltages are connected in series like Fig.(1) on the right;

1. The output current shall be the rated current or less of the smaller rated current among the PSU1 and PSU2 connected in series.
2. Connect diodes for protection as shown in the Fig.(1).  
Current rating of the diode shall be 1.5 times or more of rated output current whose unit has larger rated output current among PSU1 and PSU2.  
Also, use Schottky diodes whose forward voltage is lower than the forward voltage of the diodes used in the PSU.

(Fig.(1))



(Fig.(2))



In the case of serial connection of different output voltages, connect

### Parallel operation

Parallel operation is unacceptable.

## Optional Products

Cable				
Page	Photos	Model	Category	Description
C-H10		WH-C05VH-800	Input harness	connection to nylon connector type is available.
C-H10		WH-C05VH-800-01	Input harness (with ferrite core)	connection to nylon connector type is available.

A. UPDATE

B. SELECTION GUIDE

B. PRODUCT PAGE GUIDELINE

B. NONSTOP POWER SUPPLY

B. AC+DC DUAL-INPUT PSU

B. GENERAL PURPOSE PC PSU

B. GENERAL PURPOSE REDUNDANT PSU

B. OPTIONS

C. SELECTION GUIDE

C. PRODUCT PAGE GUIDELINE

C. AC-DC SINGLE OUTPUT NONSTOP PSU

C. AC-DC MULTI-OUTPUT NONSTOP PSU

C. AC-DC SINGLE OUTPUT POWER SUPPLY

C. AC-DC MULTI-OUTPUT POWER SUPPLY

C. DC-DC CONVERTER

C. OPTIONS

D. TECHNICAL DICTIONARY

E. COMPANY PROFILE

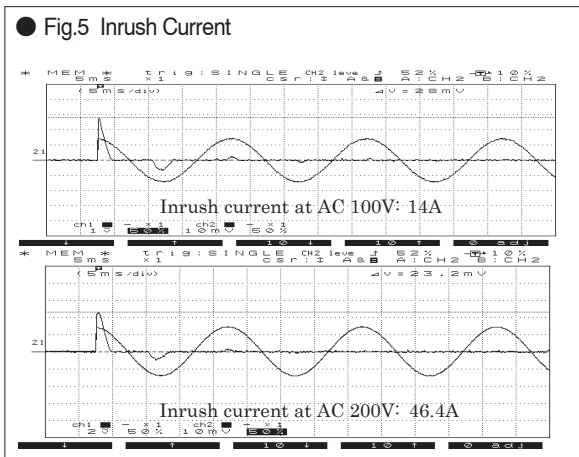
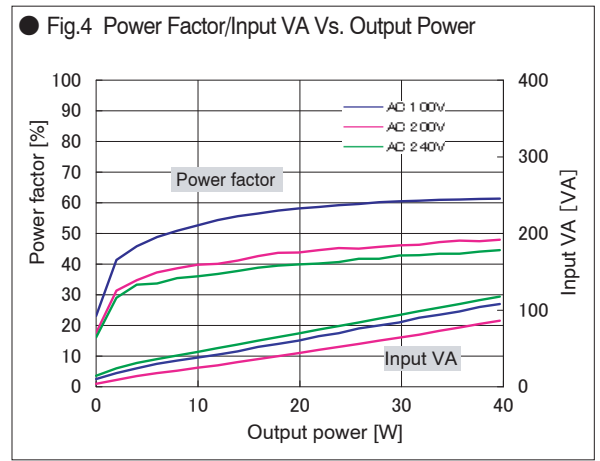
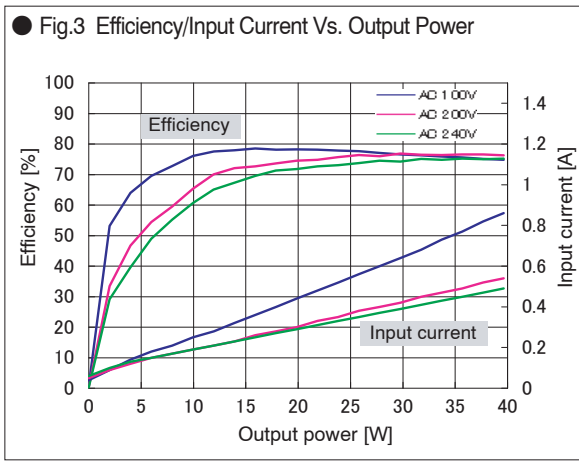
F. BUSINESS MANUAL

G. INDEX

Computer Power Supply - BRAIN

Control & Mechanism System Power Supply - LIMBS

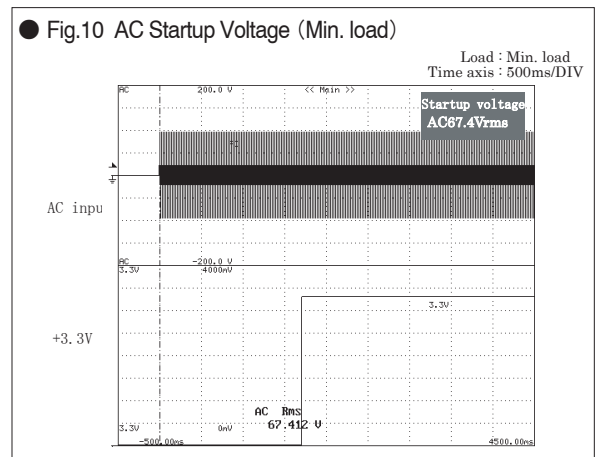
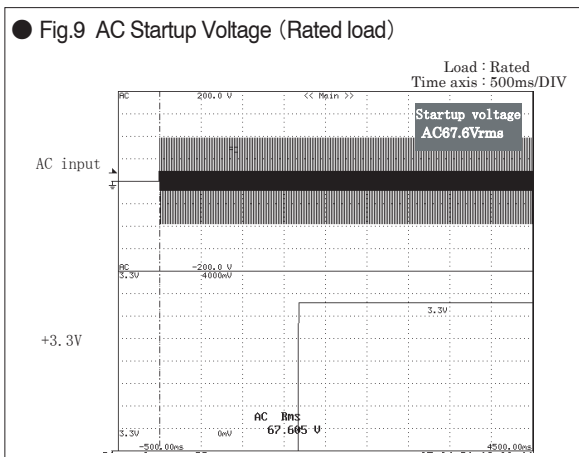
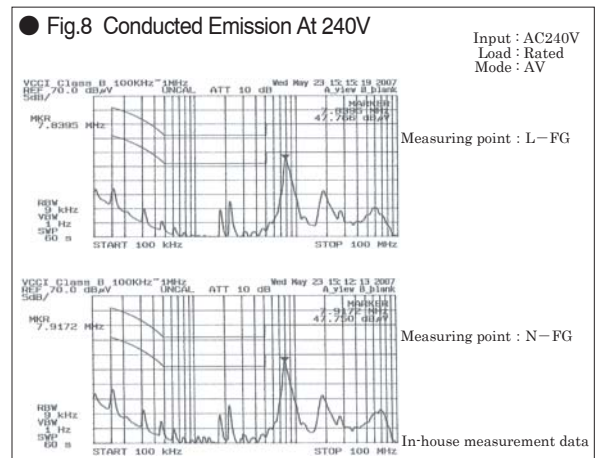
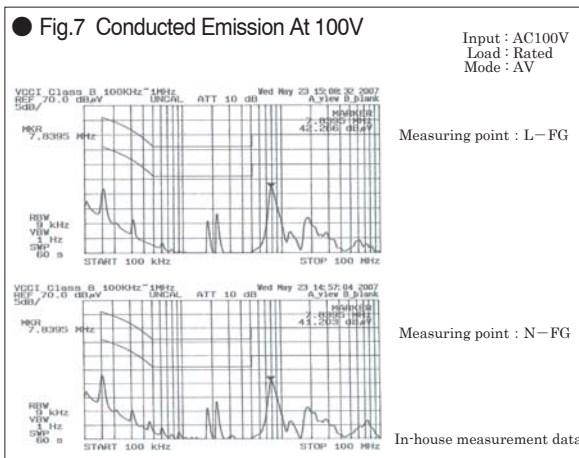
**Characteristics Data 0Z-060-3R3** (Examples of actual measurement)



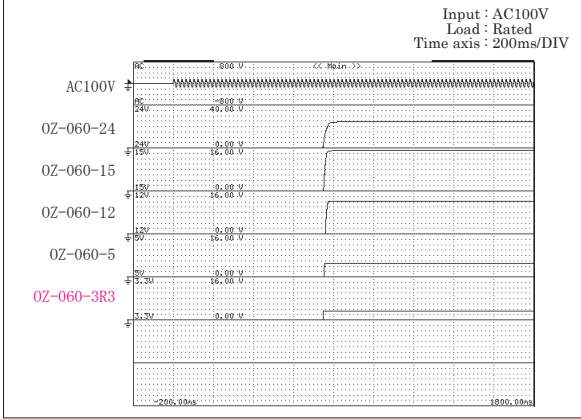
**Fig.6 Leakage Current**

Input : AC 100, 200, 240V  
Load : Rated load and Min. load

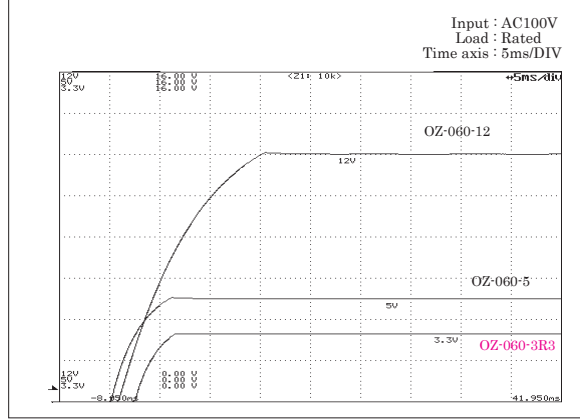
	Rated load	Min. load
AC 100V	0.15mA	0.15mA
AC 200V	0.3mA	0.3mA
AC 240V	0.38mA	0.37mA



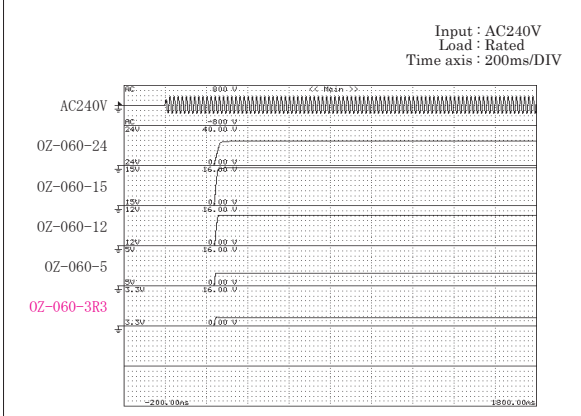
● Fig.11 Rising Sequence At AC 100V



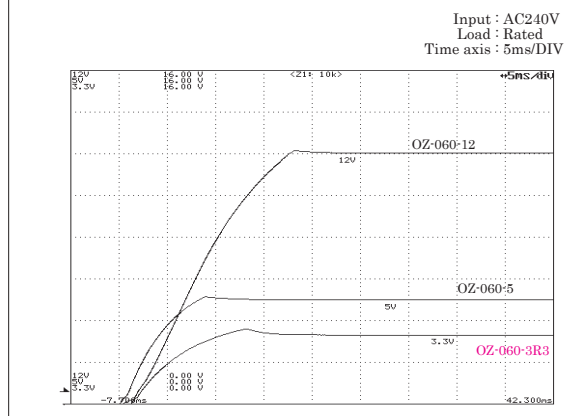
● Fig.12 Rising Characteristics At AC 100V



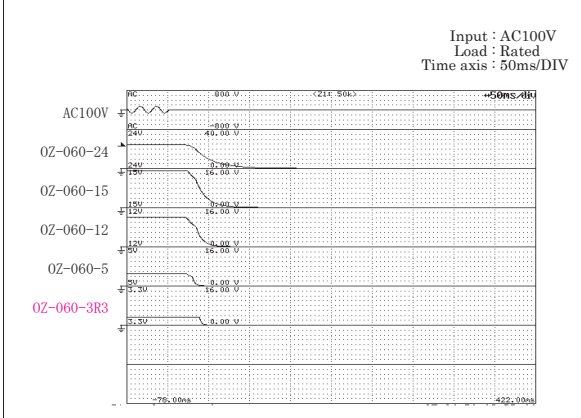
● Fig.13 Rising Sequence At AC 240V



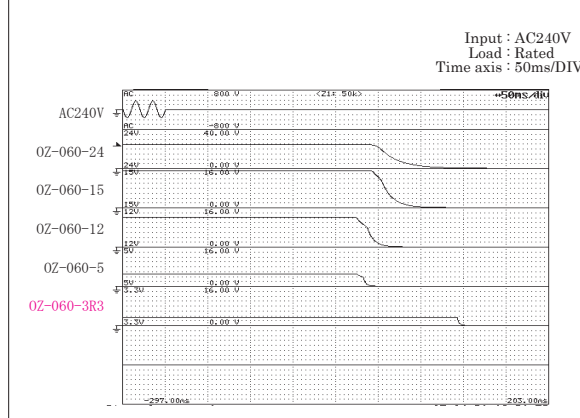
● Fig.14 Rising Characteristics At AC 240V



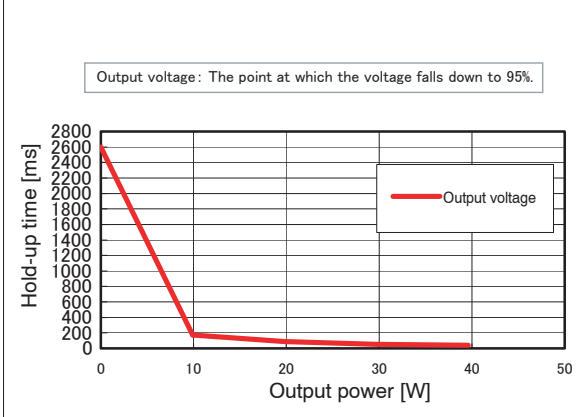
● Fig.15 Falling Characteristics At AC 100V When AC Goes Off



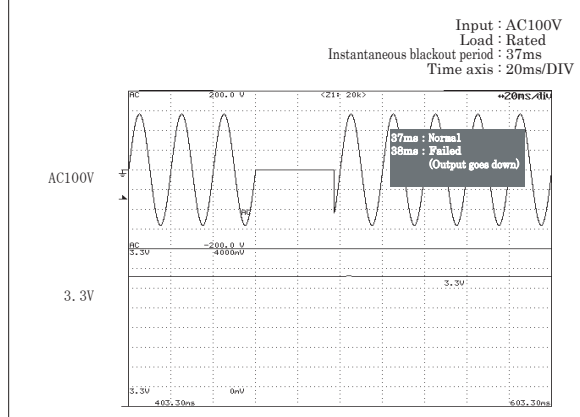
● Fig.16 Falling Characteristics At AC 240V When AC Goes Off



● Fig.17 Output Hold-up Time Vs. Output Power



● Fig.18 Instantaneous Blackout



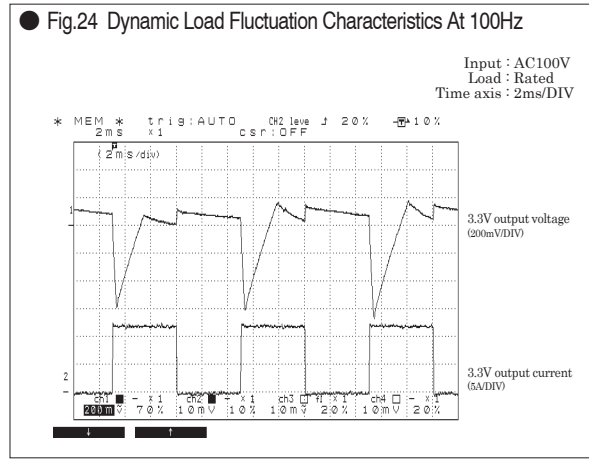
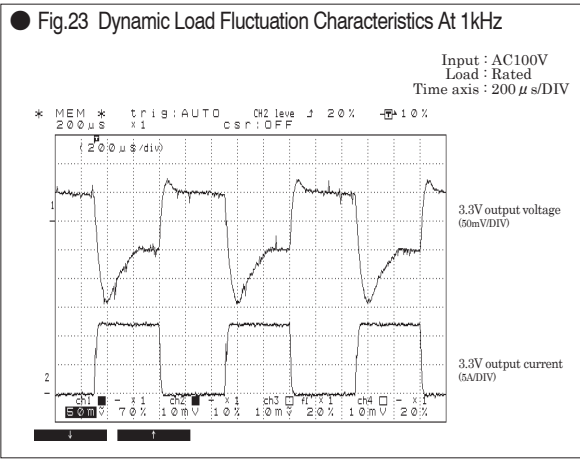
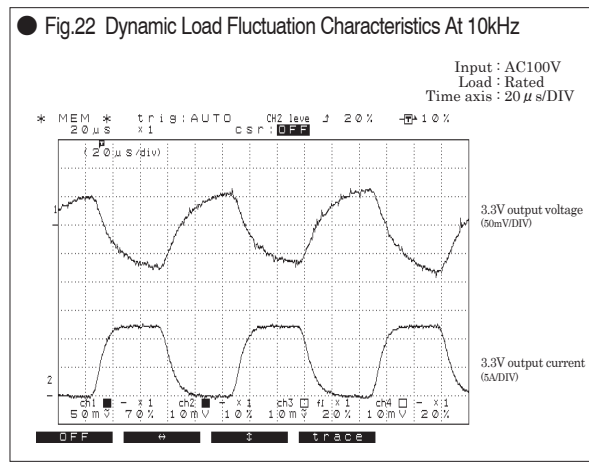
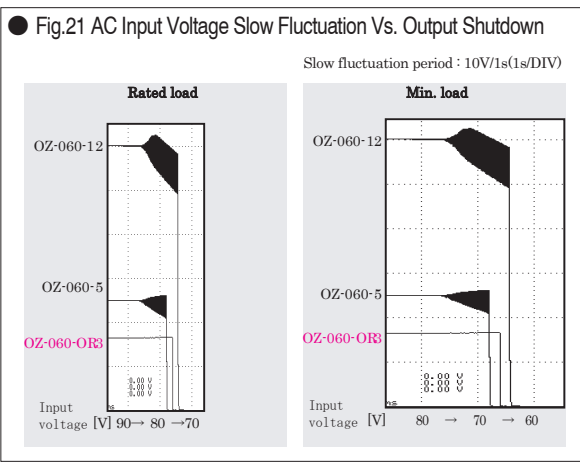
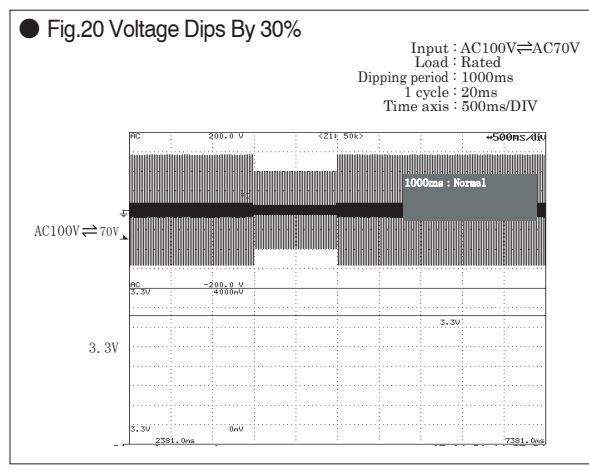
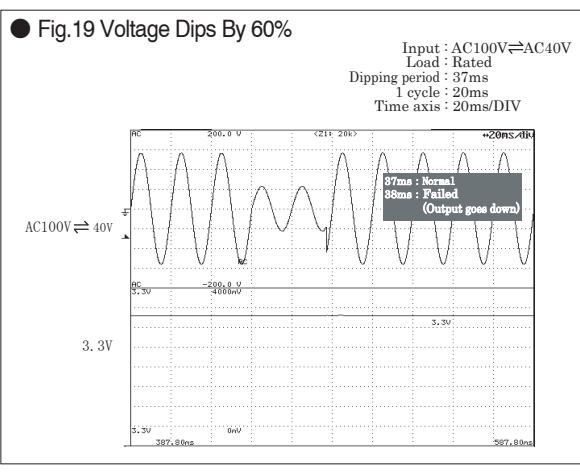
Computer Power Supply - BRAIN

- B-A SELECTION GUIDE
- B-B PRODUCT PAGE GUIDELINE
- B-C NONSTOP POWER SUPPLY
- B-D AC+DC DUAL-INPUT PSU
- B-E GENERAL PURPOSE PC PSU
- B-F GENERAL PURPOSE REDUNDANT PSU
- B-G OPTIONS

Control & Mechanism System Power Supply - LIMBS

- C-A SELECTION GUIDE
- C-B PRODUCT PAGE GUIDELINE
- C-C AC-DC SINGLE OUTPUT NONSTOP PSU
- C-D AC-DC MULTI-OUTPUT NONSTOP PSU
- C-E AC-DC SINGLE OUTPUT POWER SUPPLY
- C-F AC-DC MULTI-OUTPUT POWER SUPPLY
- C-G DC-DC CONVERTER
- C-H OPTIONS

Characteristics Data **OZ-060-3R3** (Examples of actual measurement)

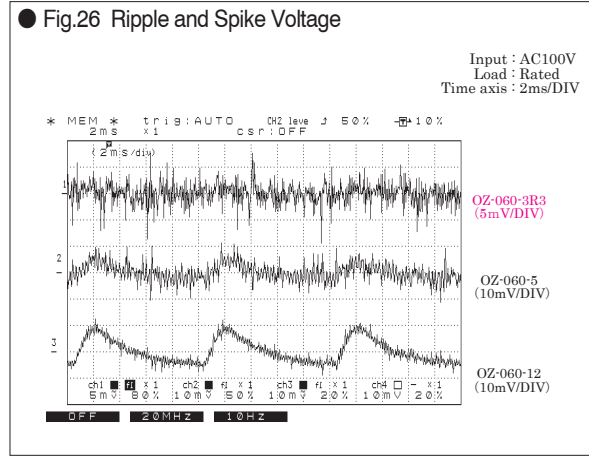


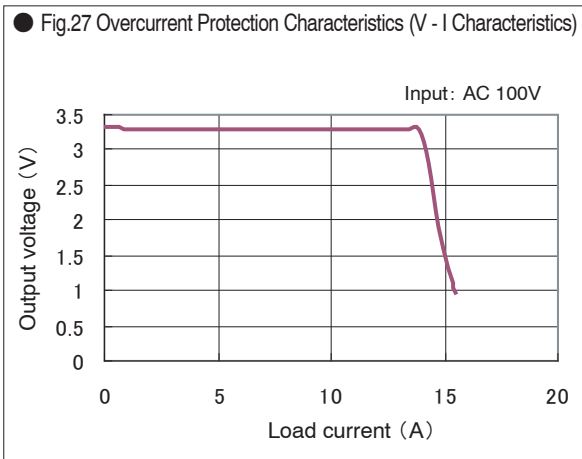
**Fig.25 Output Voltage Regulation**

	Spec.	Min. load	Rated load
3.3V load		0A	12A

AC input	AC 85V	AC 100V	AC 132V	AC 176V	AC 240V	AC 264V
3.3V load (min.)	3.312 V	3.312 V	3.312 V	3.311 V	3.311 V	3.311 V
3.3V load (50%)	3.304 V	3.304 V	3.303 V	3.303 V	3.303 V	3.302 V
3.3V load (Rated)	3.297 V	3.296 V	3.296 V	3.296 V	3.296 V	3.296 V





A. UPDATE

Computer Power Supply - BRAIN

B.<sub>A</sub> SELECTION GUIDE

B.<sub>B</sub> PRODUCT PAGE GUIDELINE

B.<sub>C</sub> NONSTOP POWER SUPPLY

B.<sub>D</sub> AC+DC DUAL-INPUT PSU

B.<sub>E</sub> GENERAL PURPOSE PC PSU

B.<sub>F</sub> GENERAL PURPOSE REDUNDANT PSU

B.<sub>G</sub> OPTIONS

Control & Mechanism System Power Supply - LIMBS

C.<sub>A</sub> SELECTION GUIDE

C.<sub>B</sub> PRODUCT PAGE GUIDELINE

C.<sub>C</sub> AC-DC SINGLE OUTPUT NONSTOP PSU

C.<sub>D</sub> AC-DC MULTI-OUTPUT NONSTOP PSU

C.<sub>E</sub> AC-DC SINGLE OUTPUT POWER SUPPLY

C.<sub>F</sub> AC-DC MULTI-OUTPUT POWER SUPPLY

C.<sub>G</sub> DC-DC CONVERTER

C.<sub>H</sub> OPTIONS

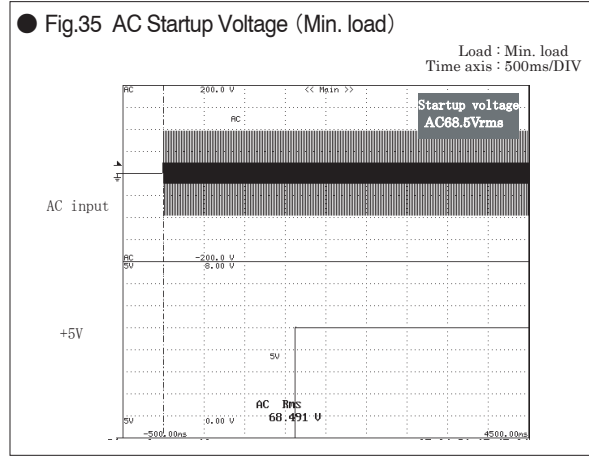
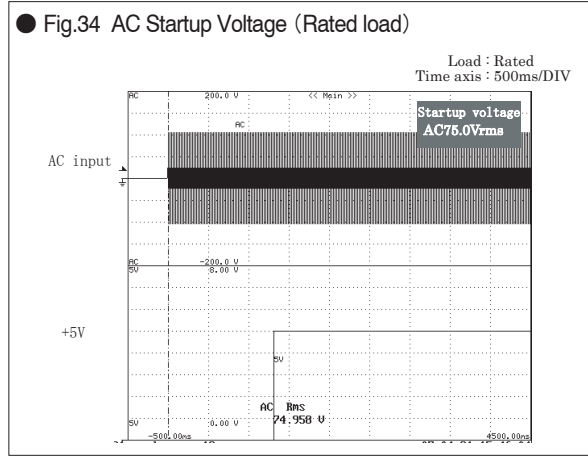
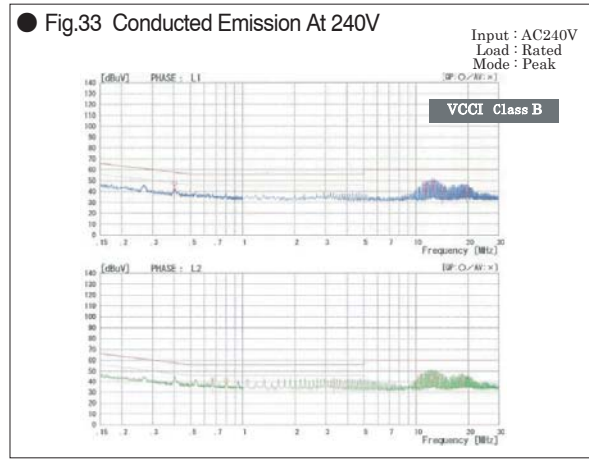
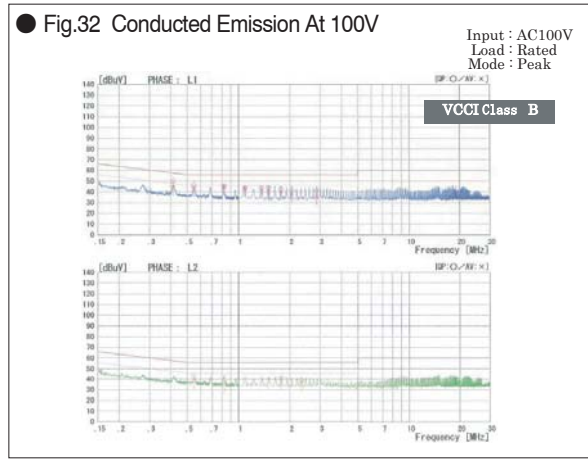
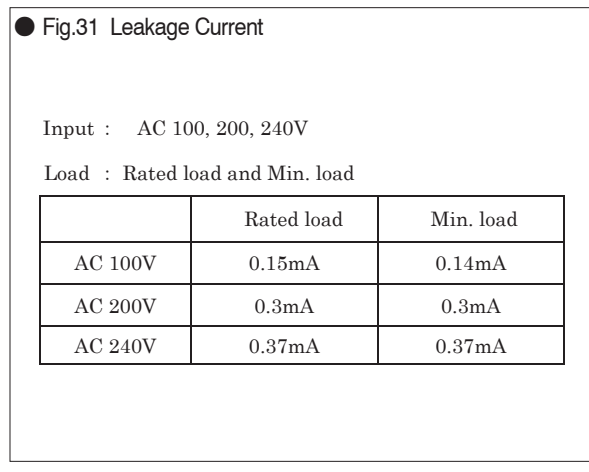
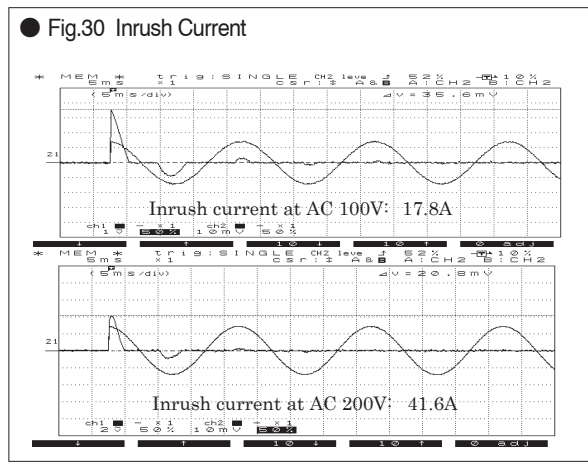
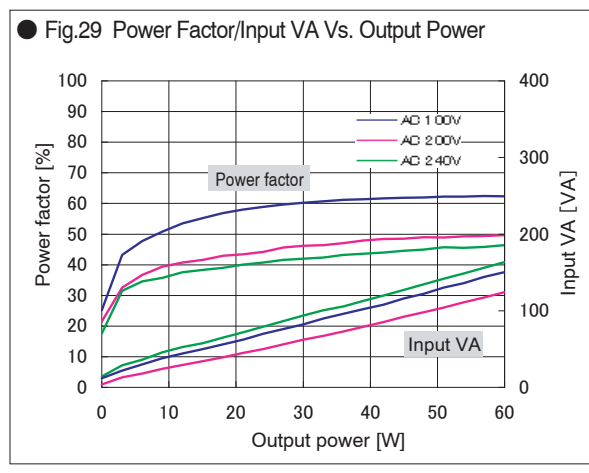
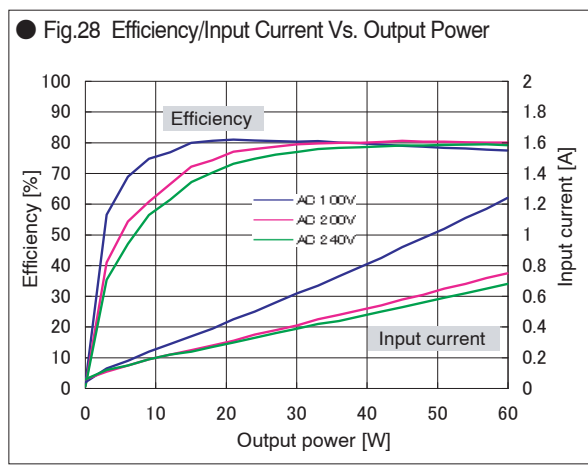
D. TECHNICAL DICTIONARY

E. COMPANY PROFILE

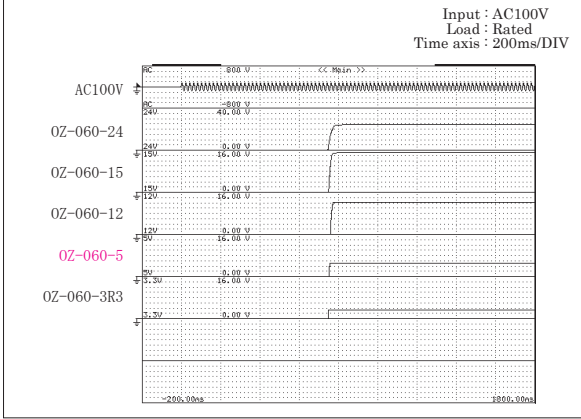
F. BUSINESS MANUAL

G. INDEX

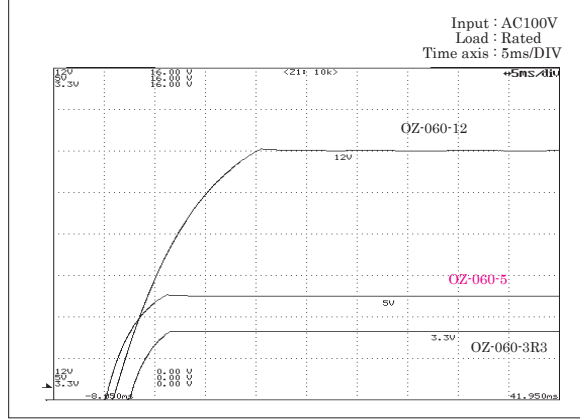
Characteristics Data **0Z-060-5** (Examples of actual measurement)



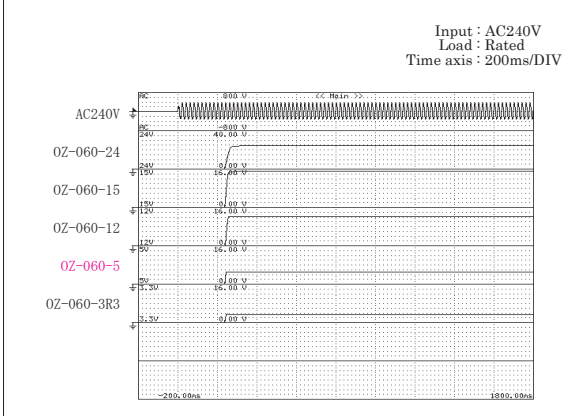
● Fig.36 Rising Sequence At AC 100V



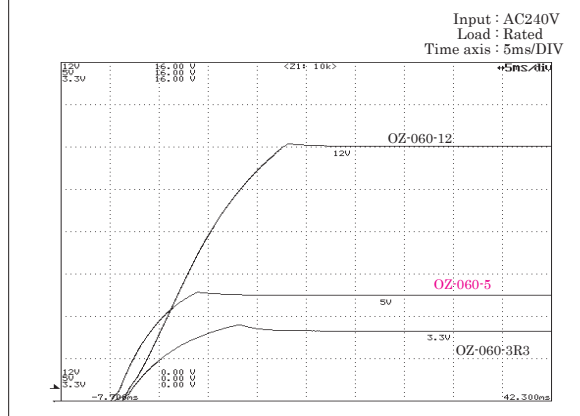
● Fig.37 Rising Characteristics At AC 100V



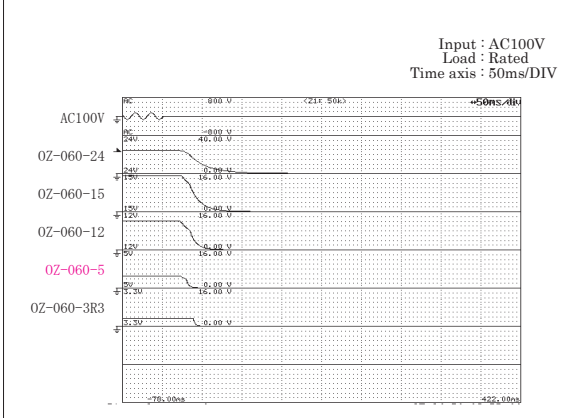
● Fig.38 Rising Sequence At AC 240V



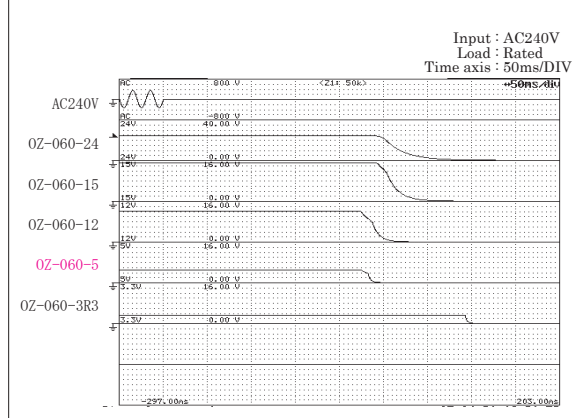
● Fig.39 Rising Characteristics At AC 240V



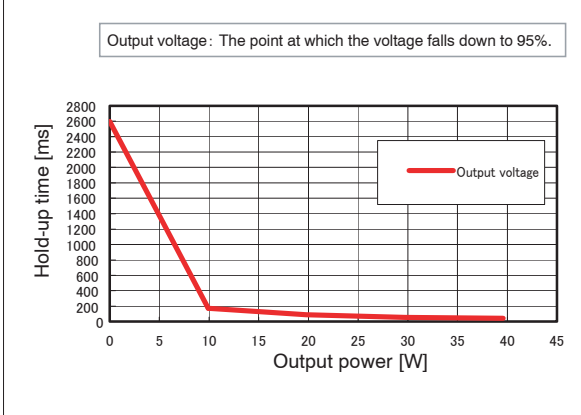
● Fig.40 Falling Characteristics At AC 100V When AC Goes Off



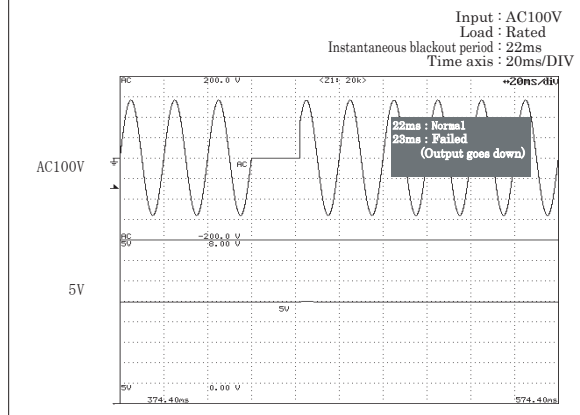
● Fig.41 Falling Characteristics At AC 240V When AC Goes Off



● Fig.42 Output Hold-up Time Vs. Output Power



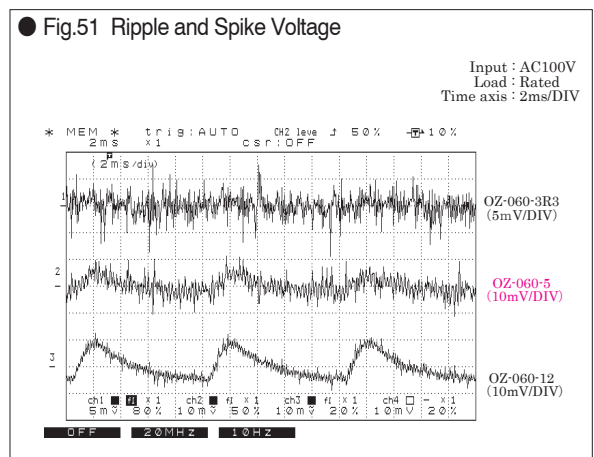
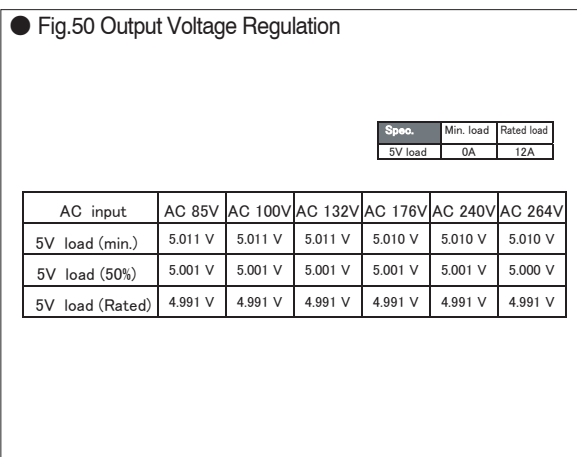
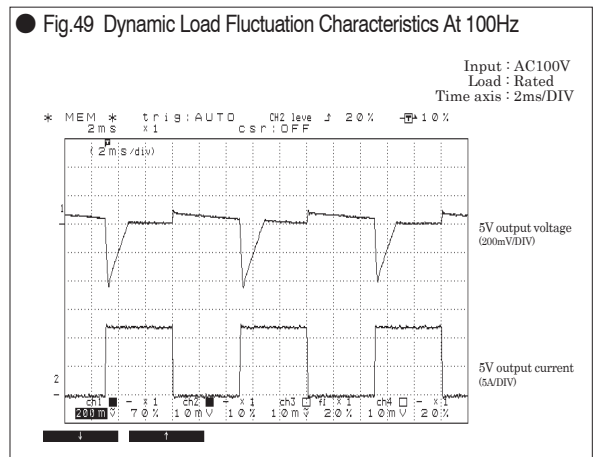
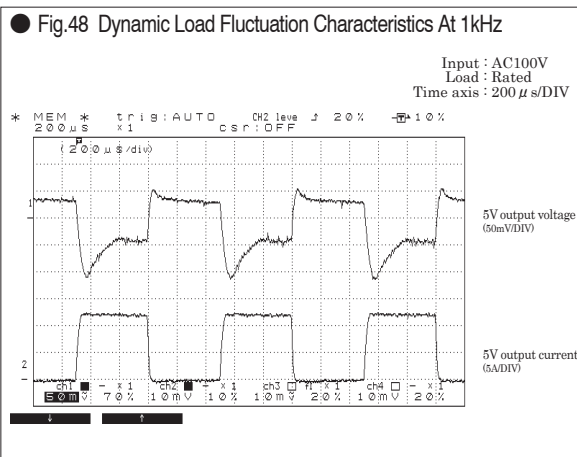
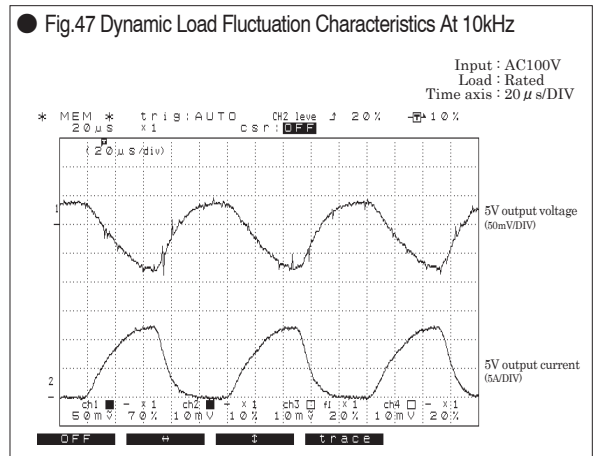
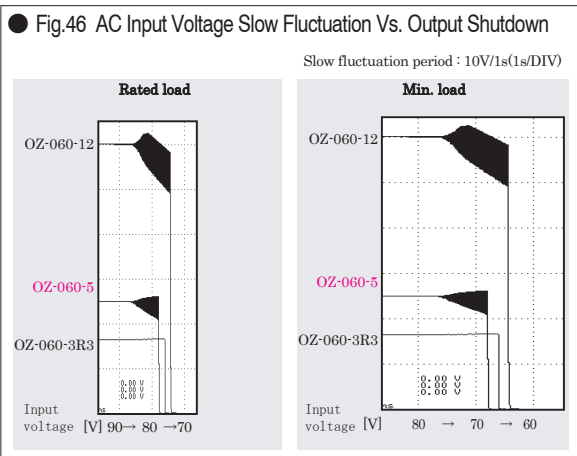
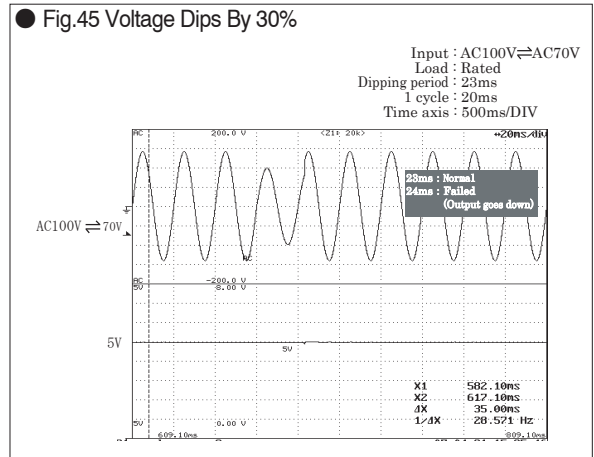
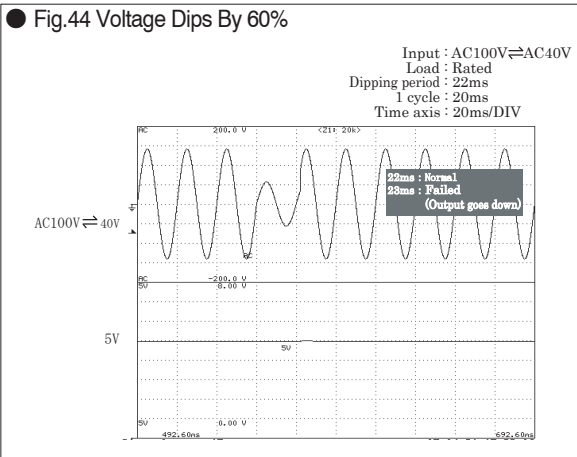
● Fig.43 Instantaneous Blackout

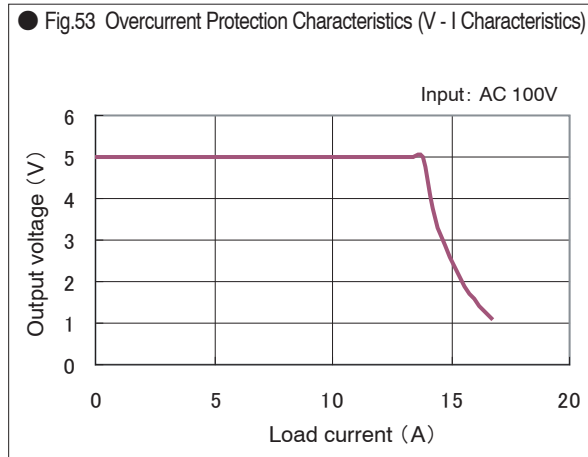
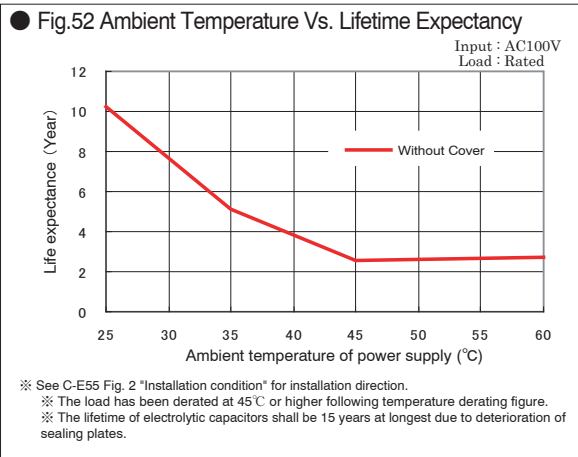


Computer Power Supply - BRAIN

Control & Mechanism System Power Supply - LIMBS

- A. UPDATE
- B-A. SELECTION GUIDE
- B-B. PRODUCT PAGE GUIDELINE
- B-C. NONSTOP POWER SUPPLY
- B-D. AC+DC DUAL-INPUT PSU
- B-E. GENERAL PURPOSE PC PSU
- B-F. GENERAL PURPOSE REDUNDANT PSU
- B-G. OPTIONS
- C-A. SELECTION GUIDE
- C-B. PRODUCT PAGE GUIDELINE
- C-C. AC-DC SINGLE OUTPUT NONSTOP PSU
- C-D. AC-DC MULTI-OUTPUT NONSTOP PSU
- C-E. AC-DC SINGLE OUTPUT POWER SUPPLY
- C-F. AC-DC MULTI-OUTPUT POWER SUPPLY
- C-G. DC-DC CONVERTER
- C-H. OPTIONS
- D. TECHNICAL DICTIONARY
- E. COMPANY PROFILE
- F. BUSINESS MANUAL
- G. INDEX





Computer Power Supply - BRAIN

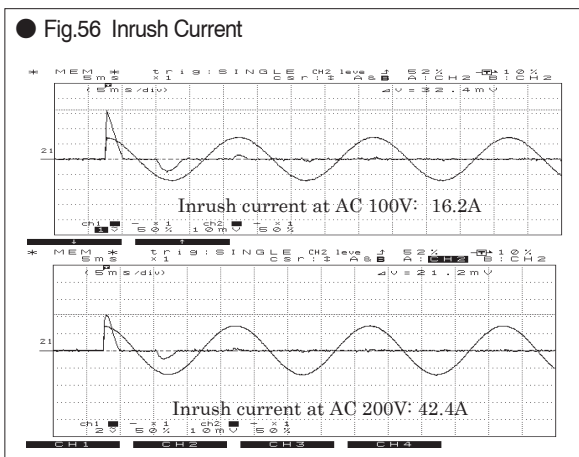
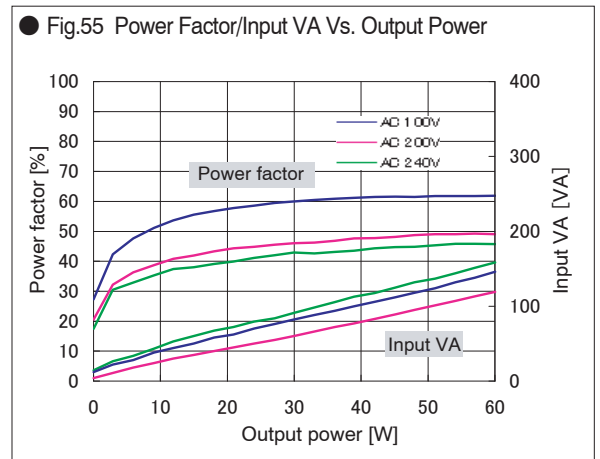
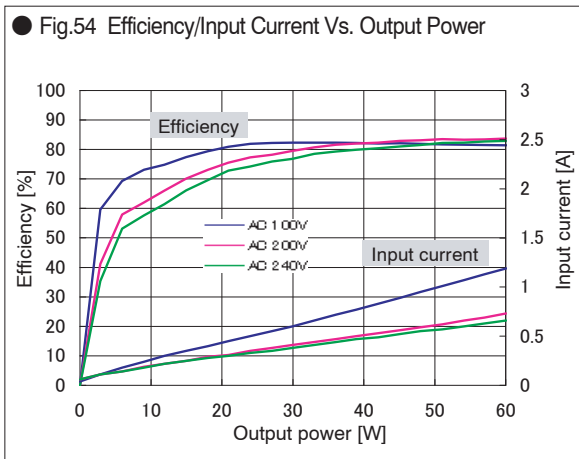
- A. UPDATE
- B.-A. SELECTION GUIDE
- B.-B. PRODUCT PAGE GUIDELINE
- B.-C. NONSTOP POWER SUPPLY
- B.-D. AC+DC DUAL-INPUT PSU
- B.-E. GENERAL PURPOSE PC PSU
- B.-F. GENERAL PURPOSE REDUNDANT PSU
- B.-G. OPTIONS

Control & Mechanism System Power Supply - LIMBS

- C.-A. SELECTION GUIDE
- C.-B. PRODUCT PAGE GUIDELINE
- C.-C. AC-DC SINGLE OUTPUT NONSTOP PSU
- C.-D. AC-DC MULTI-OUTPUT NONSTOP PSU
- C.-E. AC-DC SINGLE OUTPUT POWER SUPPLY
- C.-F. AC-DC MULTI-OUTPUT POWER SUPPLY
- C.-G. DC-DC CONVERTER
- C.-H. OPTIONS

- D. TECHNICAL DICTIONARY
- E. COMPANY PROFILE
- F. BUSINESS MANUAL
- G. INDEX

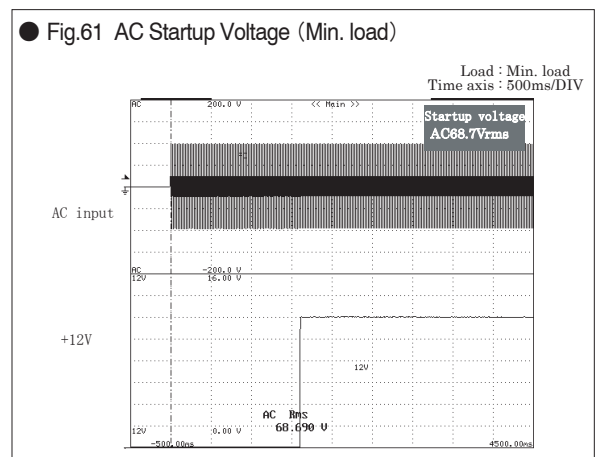
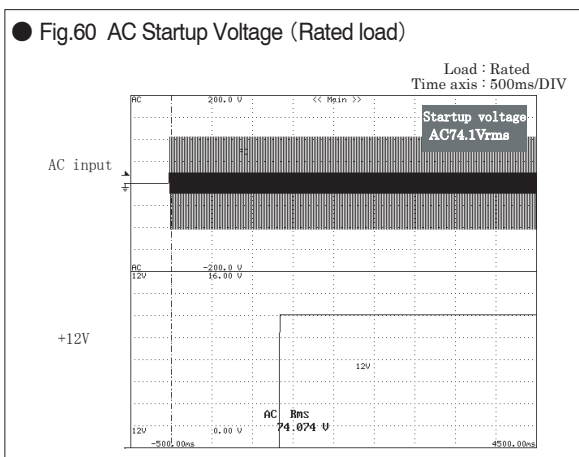
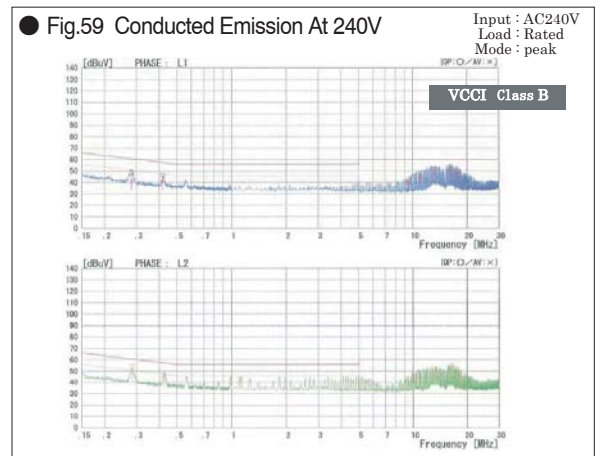
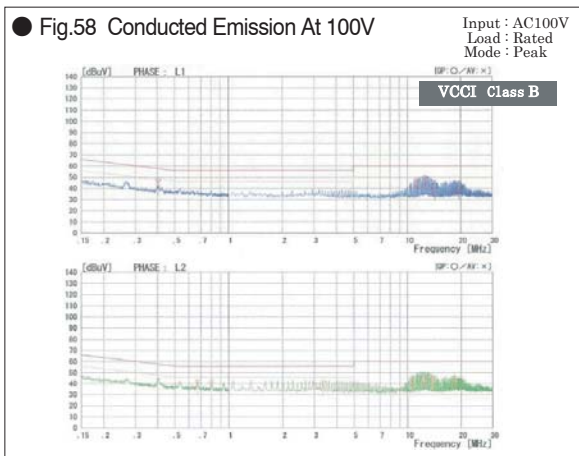
**Characteristics Data 0Z-060-12** (Examples of actual measurement)



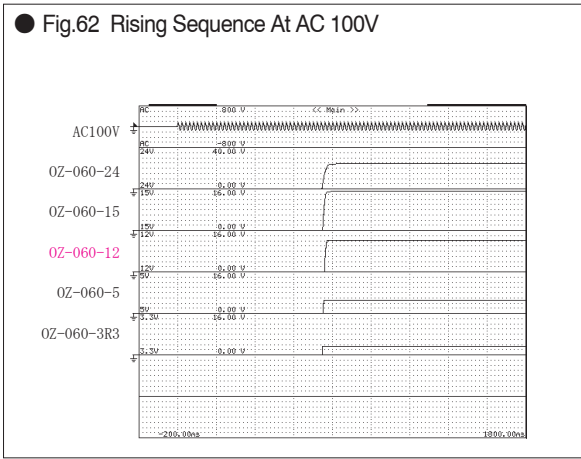
**Fig.57 Leakage Current**

Input : AC 100, 200, 240 V  
Load : Rated load and Min. load

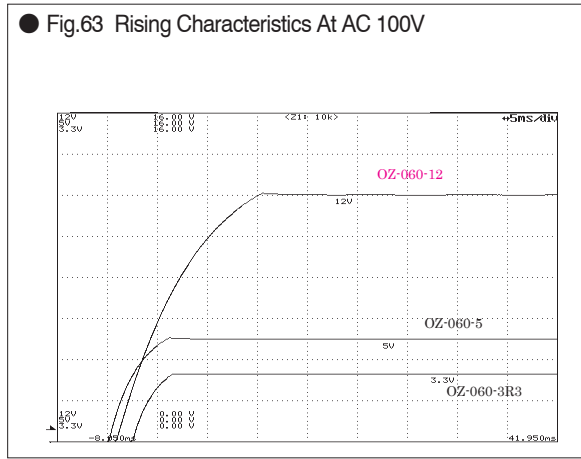
	Rated load	Min. load
AC 100V	0.19mA	0.19mA
AC 200V	0.39mA	0.39mA
AC 240V	0.48mA	0.48mA



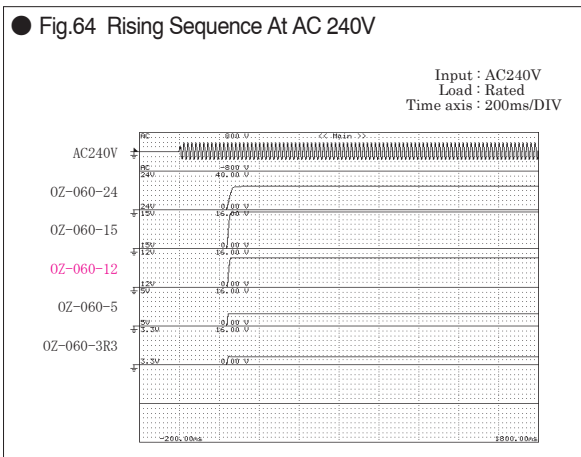
● Fig.62 Rising Sequence At AC 100V



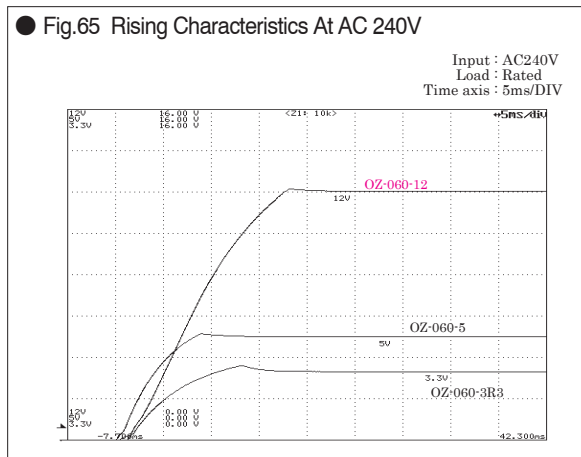
● Fig.63 Rising Characteristics At AC 100V



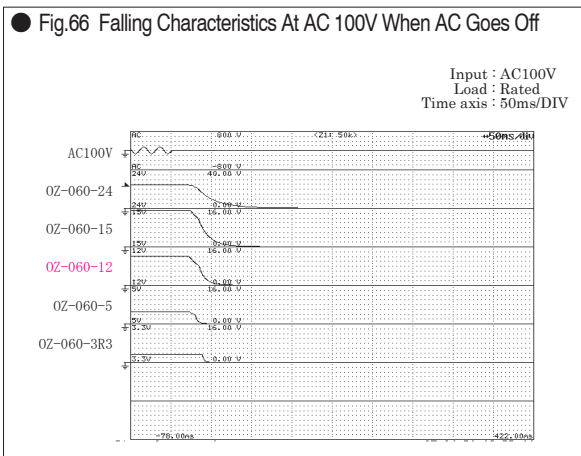
● Fig.64 Rising Sequence At AC 240V



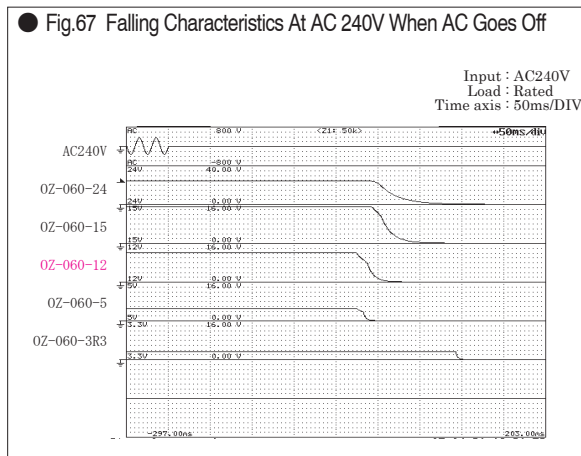
● Fig.65 Rising Characteristics At AC 240V



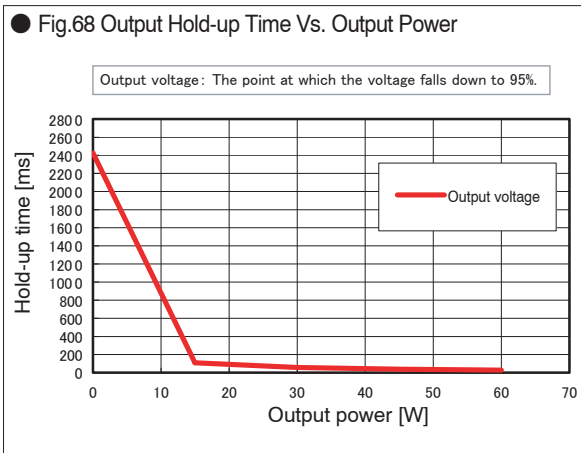
● Fig.66 Falling Characteristics At AC 100V When AC Goes Off



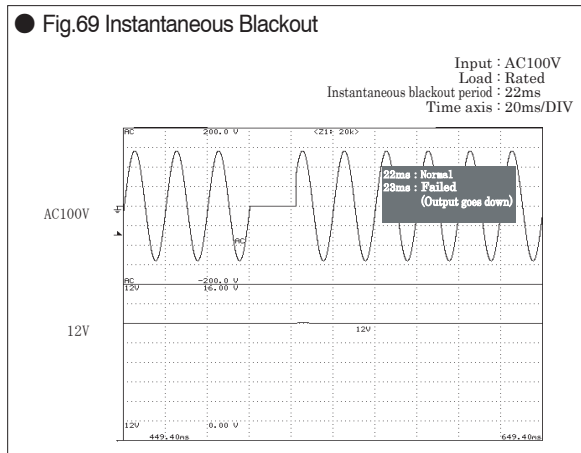
● Fig.67 Falling Characteristics At AC 240V When AC Goes Off



● Fig.68 Output Hold-up Time Vs. Output Power



● Fig.69 Instantaneous Blackout



Computer Power Supply - BRAIN

Control & Mechanism System Power Supply - LIMBS

SELECTION GUIDE  
B.-A.

PRODUCT PAGE GUIDELINE  
B.-B.

NONSTOP POWER SUPPLY  
B.-C.

AC+DC DUAL-INPUT PSU  
B.-D.

GENERAL PURPOSE PC PSU  
B.-E.

GENERAL PURPOSE REDUNDANT PSU  
B.-F.

OPTIONS  
B.-G.

SELECTION GUIDE  
C.-A.

PRODUCT PAGE GUIDELINE  
C.-B.

AC-DC SINGLE OUTPUT NONSTOP PSU  
C.-C.

AC-DC MULTI-OUTPUT NONSTOP PSU  
C.-D.

AC-DC SINGLE OUTPUT POWER SUPPLY  
C.-E.

AC-DC MULTI-OUTPUT POWER SUPPLY  
C.-F.

DC-DC CONVERTER  
C.-G.

OPTIONS  
C.-H.

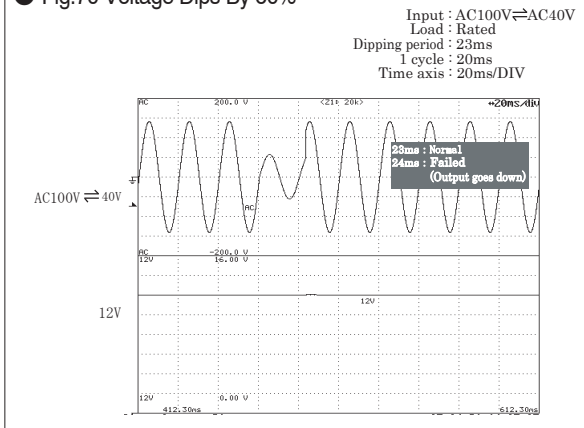
TECHNICAL DICTIONARY  
D.

COMPANY PROFILE  
E.

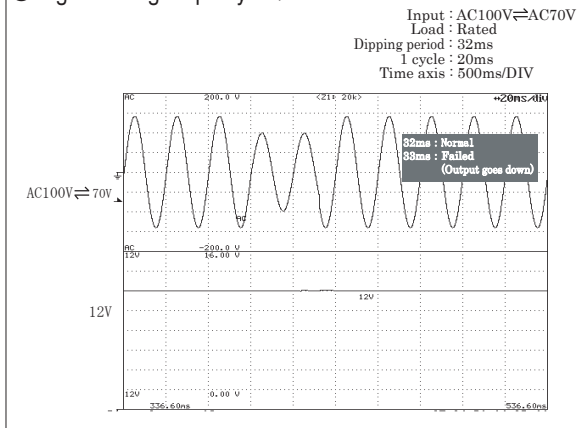
BUSINESS MANUAL  
F.

INDEX  
G.

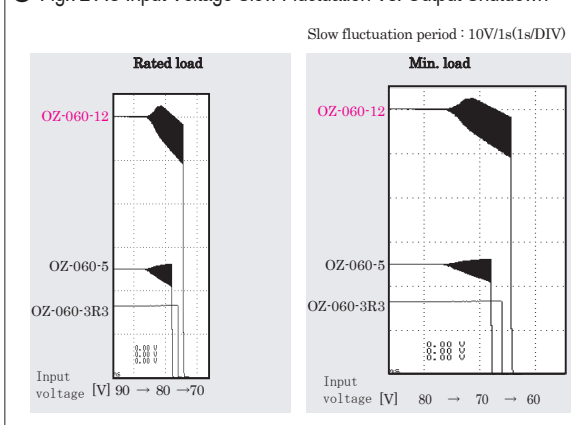
● Fig.70 Voltage Dips By 60%



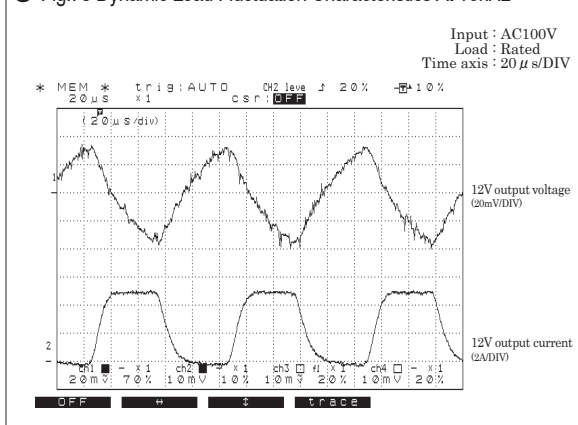
● Fig.71 Voltage Dips By 30%



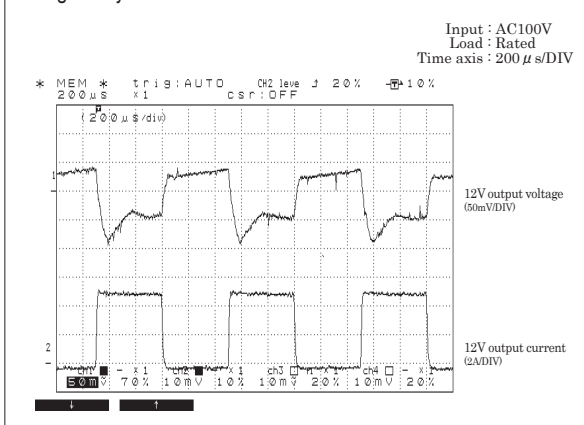
● Fig.72 AC Input Voltage Slow Fluctuation Vs. Output Shutdown



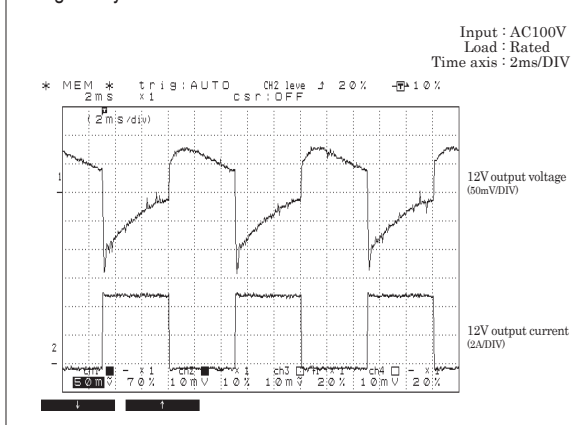
● Fig.73 Dynamic Load Fluctuation Characteristics At 10kHz



● Fig.74 Dynamic Load Fluctuation Characteristics At 1kHz



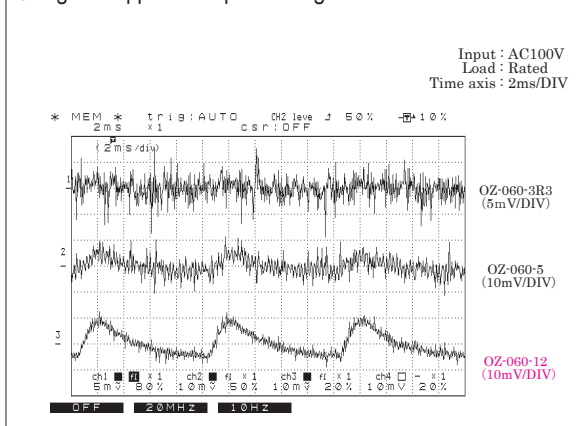
● Fig.75 Dynamic Load Fluctuation Characteristics At 100Hz

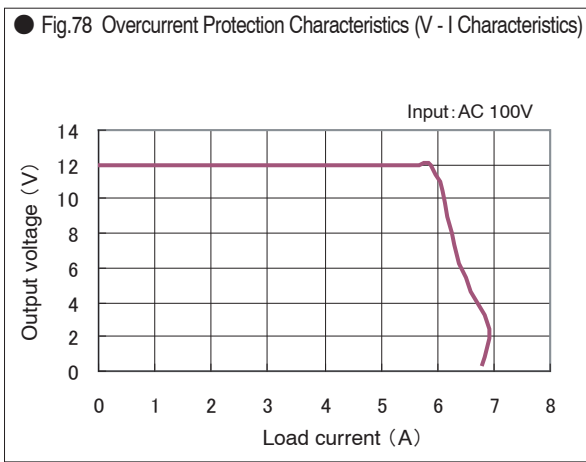


● Fig.76 Output Voltage Regulation

	Specs.					
	12V load	0A	Rated load			
AC input	AC 85V	AC 100V	AC 132V	AC 176V	AC 240V	AC 264V
12V load (min.)	12.042 V	12.043 V	12.042 V	12.042 V	12.041 V	12.040 V
12V load (50%)	12.037 V	12.036 V	12.037 V	12.035 V	12.035 V	12.034 V
12V load (Rated)	12.033 V	12.033 V	12.031 V	12.031 V	12.031 V	12.031 V

● Fig.77 Ripple and Spike Voltage





Column 31

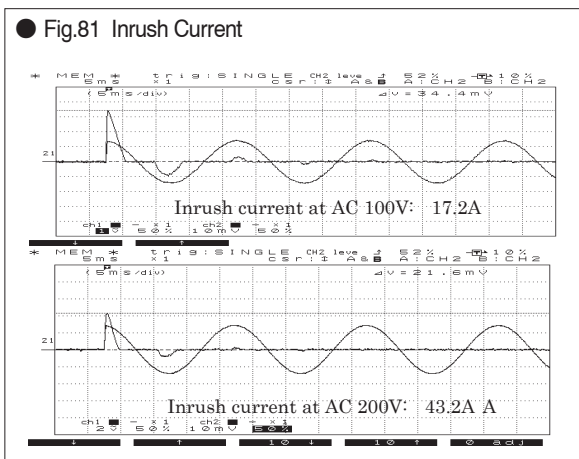
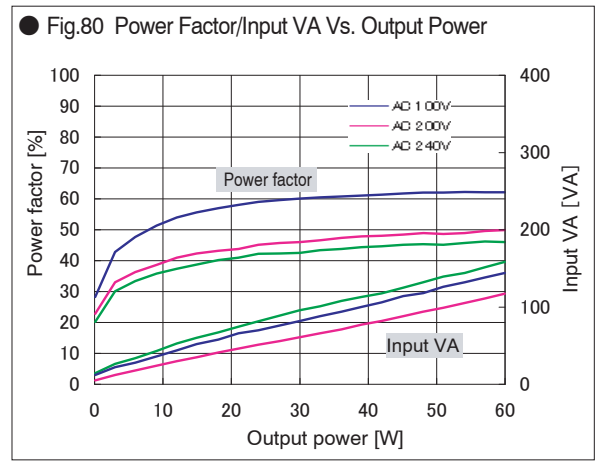
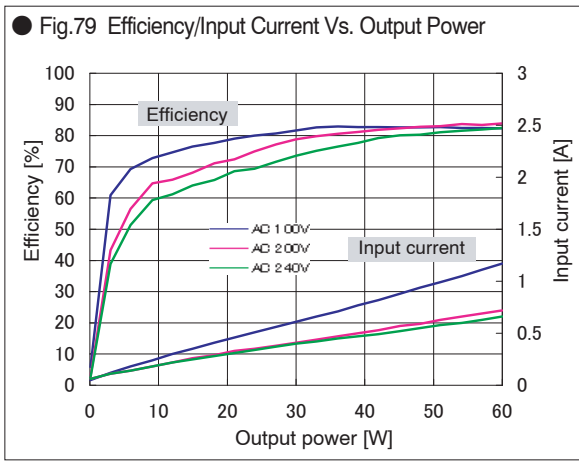
### Power Supply Policy

"Power supply (Heart) should never go broken."  
 "It must keep on pumping clean current (Blood) until the life of the equipment (Body)."

Switching power supplies Nipron presents is, so to say, a very special unit referring to "Heart of the equipment) as it protects systems of devices and equipments from all power stress, such as Impulse noise, abrupt change of supply mains, and sending clean and stable power to loads.  
 We drive the concept, "Guard" into power supplies as our basic policy.  
 It is the very business theme for us to put "Power Policy" in practice.

- A. UPDATE
- Computer Power Supply - BRAIN
  - B.-A SELECTION GUIDE
  - B.-B PRODUCT PAGE GUIDELINE
  - B.-C NONSTOP POWER SUPPLY
  - B.-D AC+DC DUAL-INPUT PSU
  - B.-E GENERAL PURPOSE PC PSU
  - B.-F GENERAL PURPOSE REDUNDANT PSU
  - B.-G OPTIONS
- Control & Mechanism System Power Supply - LIMBS
  - C.-A SELECTION GUIDE
  - C.-B PRODUCT PAGE GUIDELINE
  - C.-C AC-DC SINGLE OUTPUT NONSTOP PSU
  - C.-D AC-DC MULTI-OUTPUT NONSTOP PSU
  - C.-E AC-DC SINGLE OUTPUT POWER SUPPLY
  - C.-F AC-DC MULTI-OUTPUT POWER SUPPLY
  - C.-G DC-DC CONVERTER
  - C.-H OPTIONS
- D. TECHNICAL DICTIONARY
- E. COMPANY PROFILE
- F. BUSINESS MANUAL
- G. INDEX

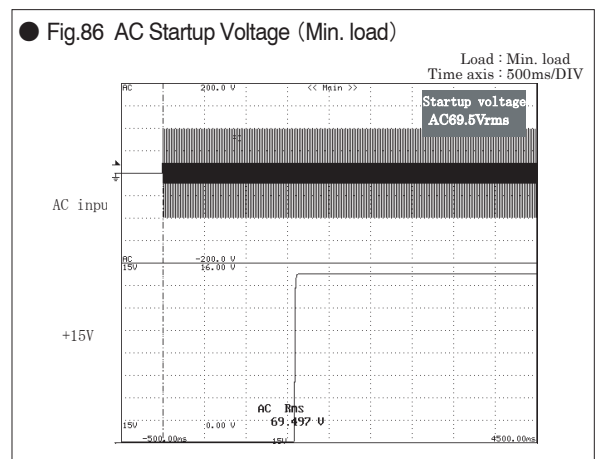
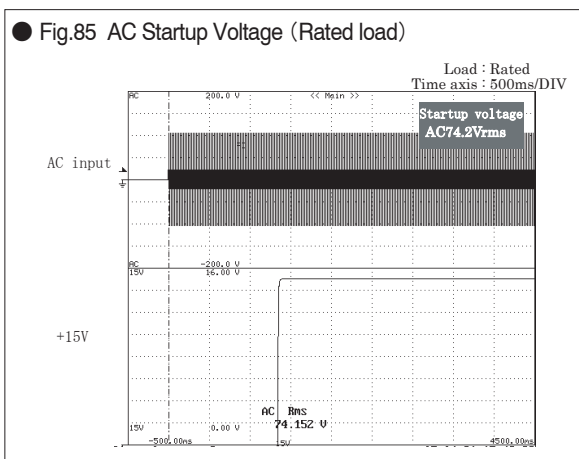
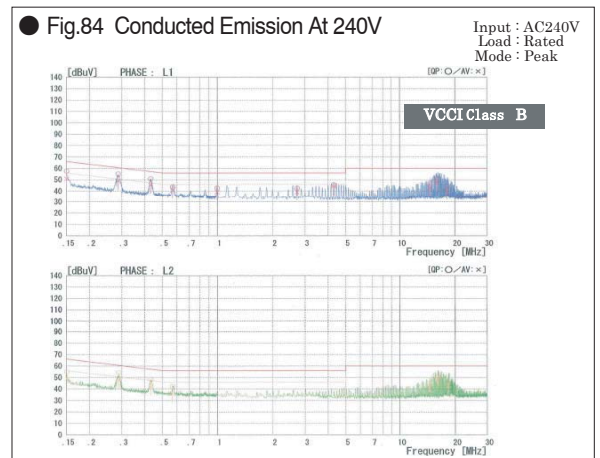
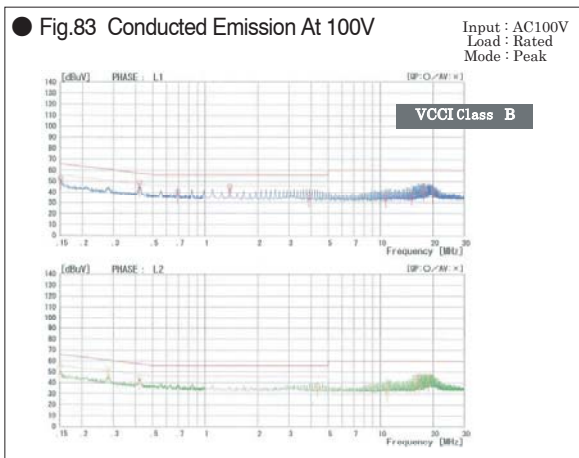
**Characteristics Data 0Z-060-15** (Examples of actual measurement)

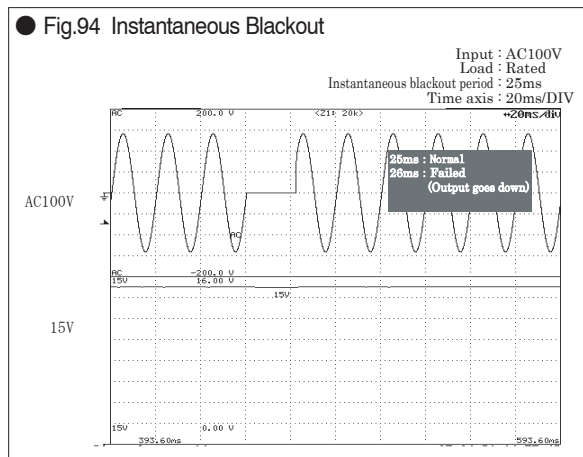
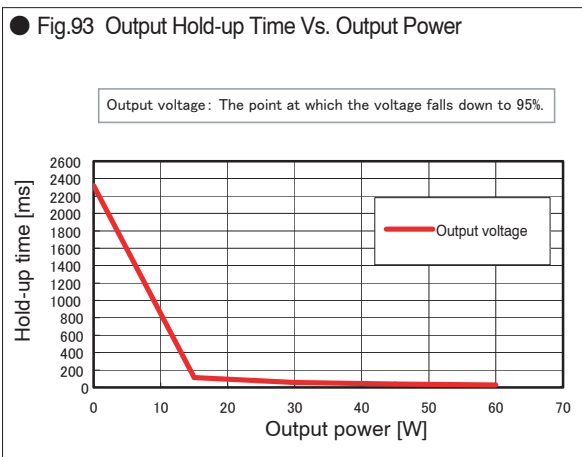
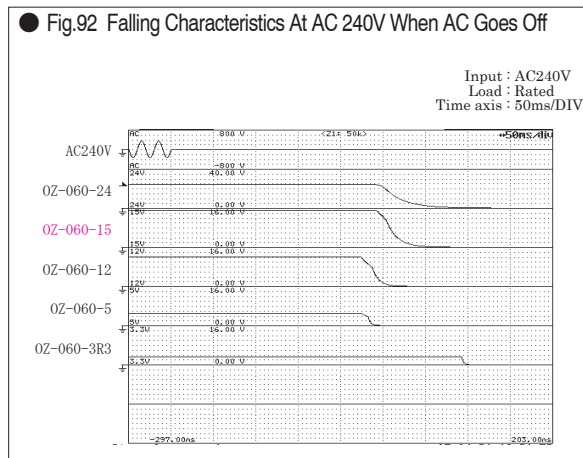
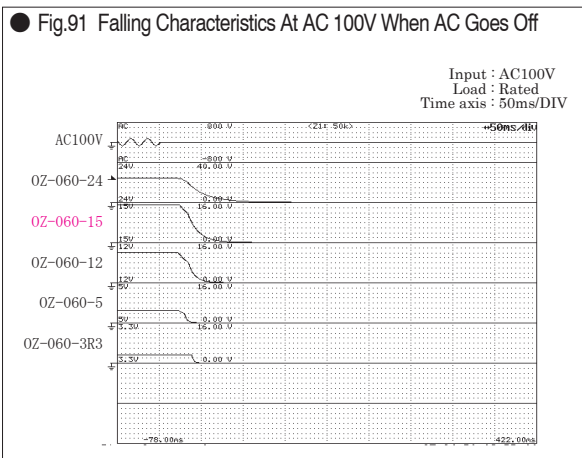
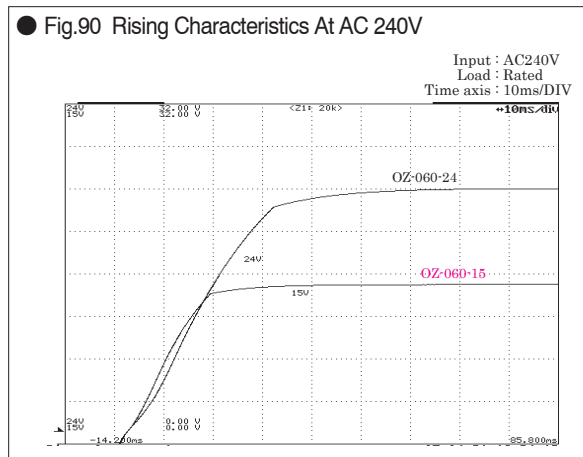
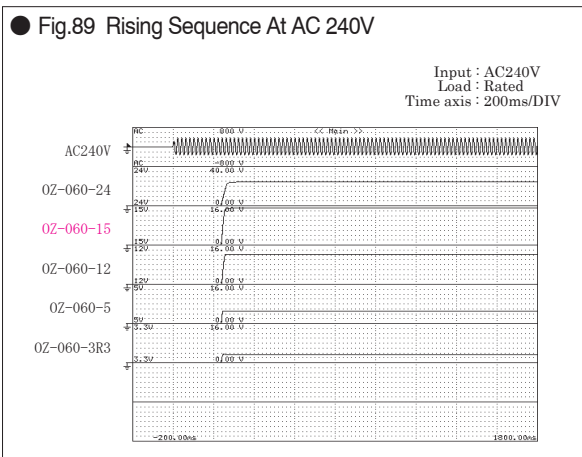
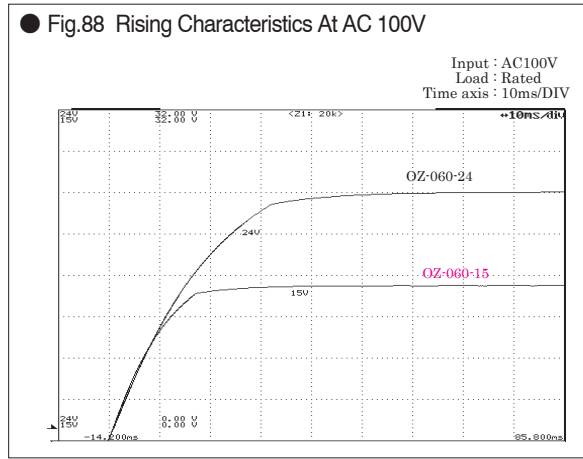
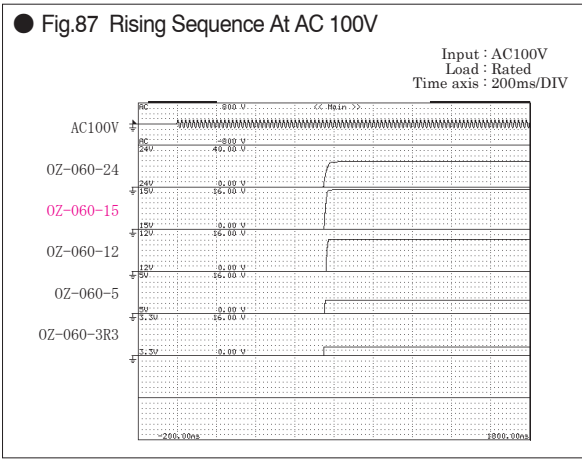


**Fig.82 Leakage Current**

Input : AC 100, 200, 240V  
Load : Rated load and Min. load

	Rated load	Min. load
AC 100V	0.2mA	0.18mA
AC 200V	0.41mA	0.4mA
AC 240V	0.48mA	0.49mA

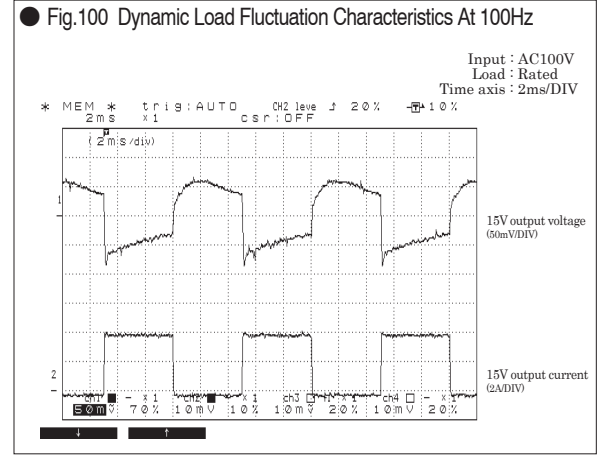
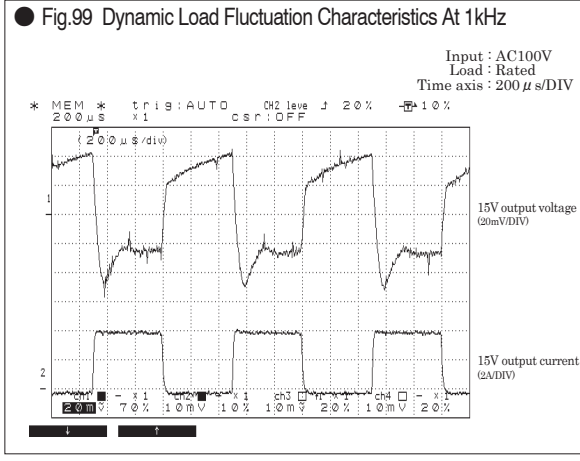
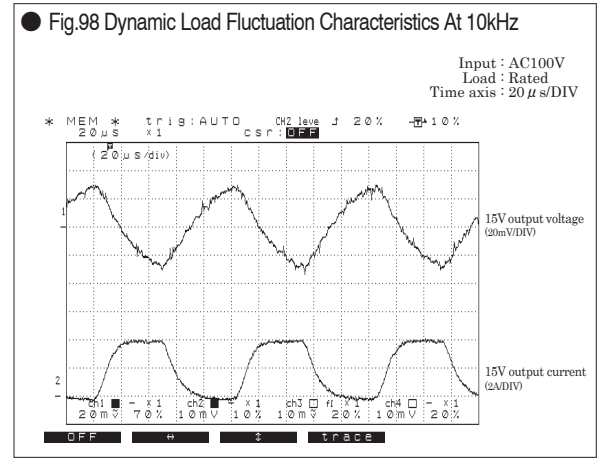
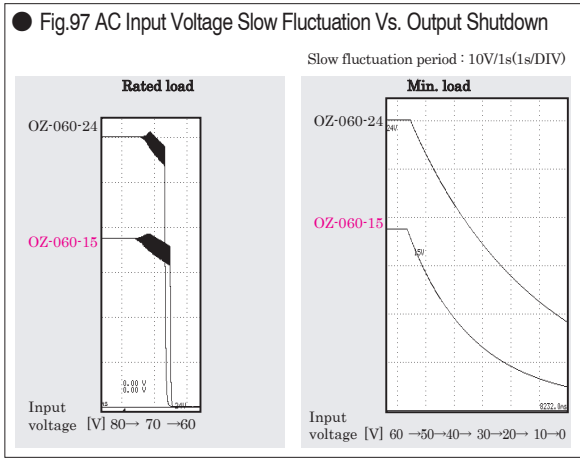
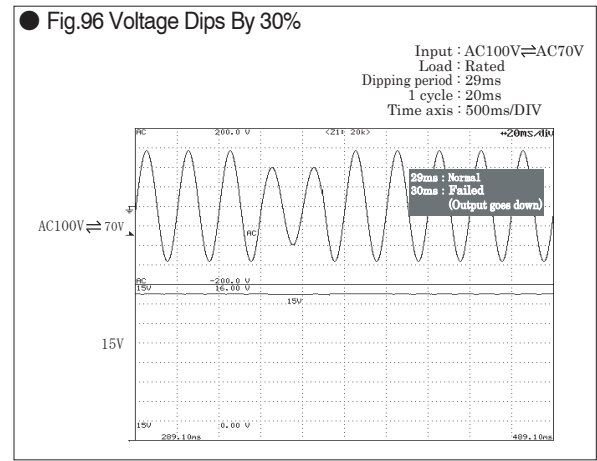
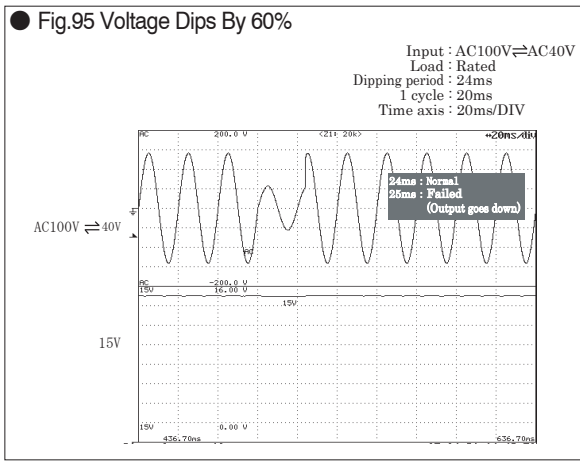




Computer Power Supply - BRAIN

- A. UPDATE
- B. SELECTION GUIDE
  - B.-A. PRODUCT PAGE GUIDELINE
  - B.-B. NONSTOP POWER SUPPLY
  - B.-C. AC+DC DUAL-INPUT PSU
  - B.-D. GENERAL PURPOSE PC PSU
  - B.-E. GENERAL PURPOSE REDUNDANT PSU
  - B.-F. OPTIONS
- Control & Mechanism System Power Supply - LIMBS
  - C. SELECTION GUIDE
    - C.-A. PRODUCT PAGE GUIDELINE
    - C.-B. AC-DC SINGLE OUTPUT NONSTOP PSU
    - C.-C. AC-DC MULTI-OUTPUT NONSTOP PSU
    - C.-D. AC-DC SINGLE OUTPUT POWER SUPPLY
    - C.-E. AC-DC MULTI-OUTPUT POWER SUPPLY
    - C.-F. DC-DC CONVERTER
    - C.-G. OPTIONS
  - D. TECHNICAL DICTIONARY
  - E. COMPANY PROFILE
  - F. BUSINESS MANUAL
  - G. INDEX

**Characteristics Data OZ-060-15** (Examples of actual measurement)

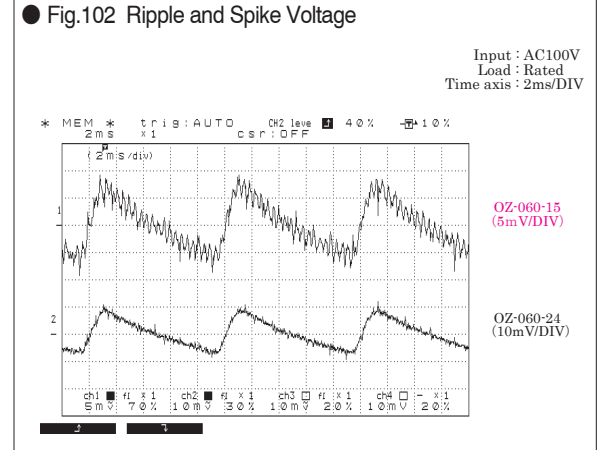


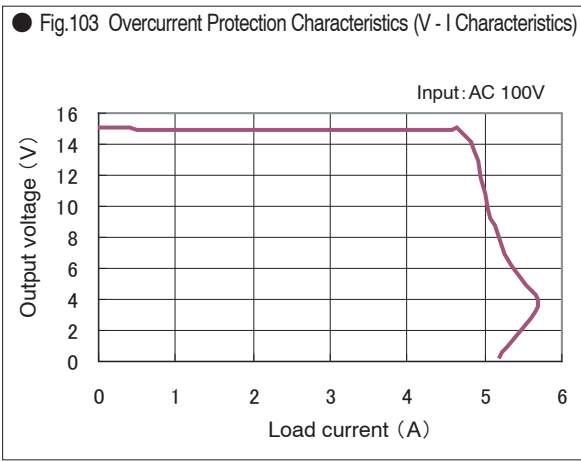
**Fig.101 Output Voltage Regulation**

	Spec.	Min. load	Rated load
15V load		0A	4A

	AC input	AC 85V	AC 100V	AC 132V	AC 176V	AC 240V	AC 264V
15V load (min.)		15.023 V	15.022 V	15.023 V	15.021 V	15.019 V	15.019 V
15V load (50%)		15.018 V	15.018 V	15.017 V	15.016 V	15.017 V	15.015 V
15V load (Rated)		15.014 V	15.013 V	15.014 V	15.013 V	15.011 V	15.011 V





A. UPDATE

Computer Power Supply - BRAIN

B.-A SELECTION GUIDE

B.-B PRODUCT PAGE GUIDELINE

B.-C NONSTOP POWER SUPPLY

B.-D AC+DC DUAL-INPUT PSU

B.-E GENERAL PURPOSE PC PSU

B.-F GENERAL PURPOSE REDUNDANT PSU

B.-G OPTIONS

Control & Mechanism System Power Supply - LIMBS

C.-A SELECTION GUIDE

C.-B PRODUCT PAGE GUIDELINE

C.-C AC-DC SINGLE OUTPUT NONSTOP PSU

C.-D AC-DC MULTI-OUTPUT NONSTOP PSU

**C.-E AC-DC SINGLE OUTPUT POWER SUPPLY**

C.-F AC-DC MULTI-OUTPUT POWER SUPPLY

C.-G DC-DC CONVERTER

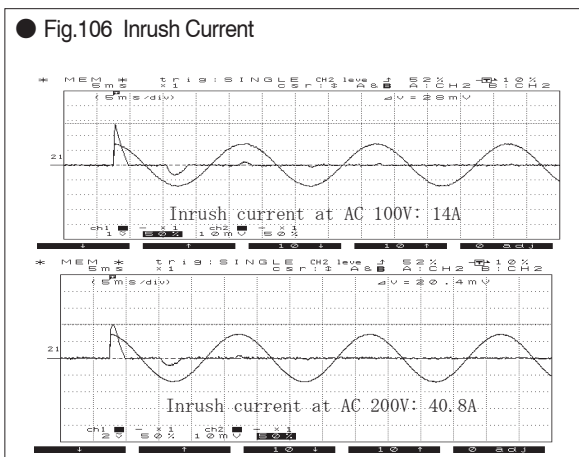
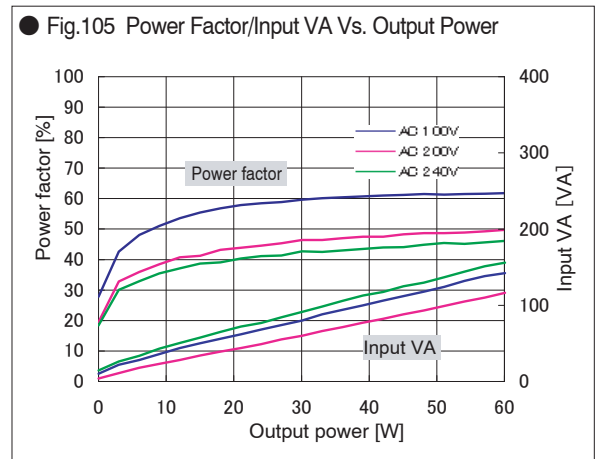
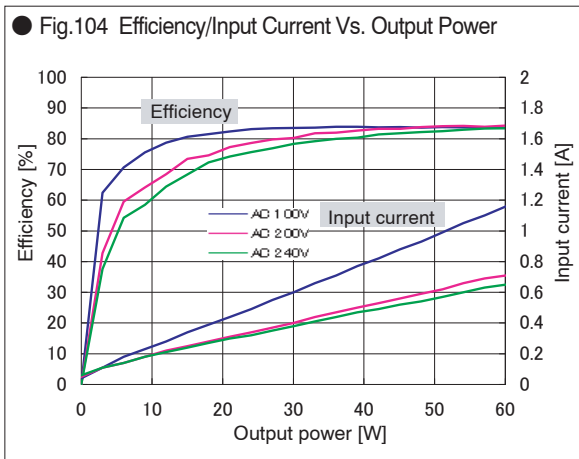
C.-H OPTIONS

D. TECHNICAL DICTIONARY

E. COMPANY PROFILE

F. BUSINESS MANUAL

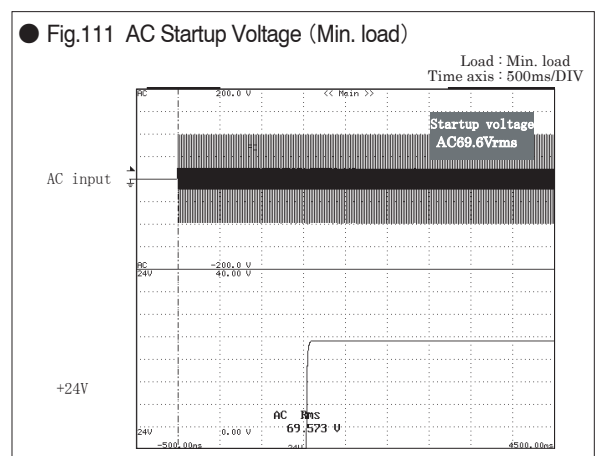
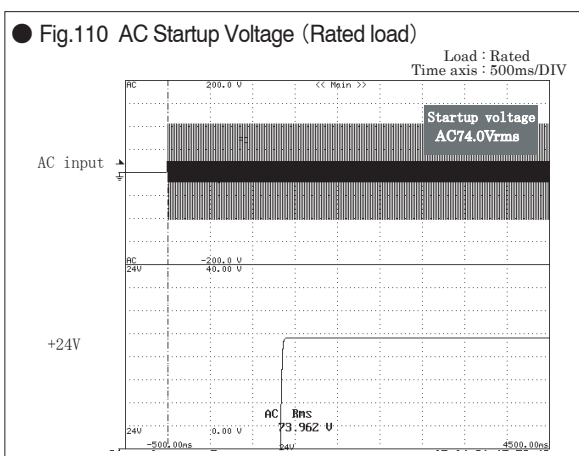
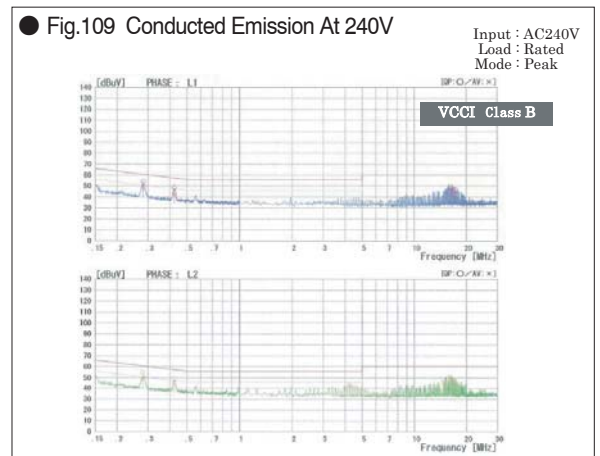
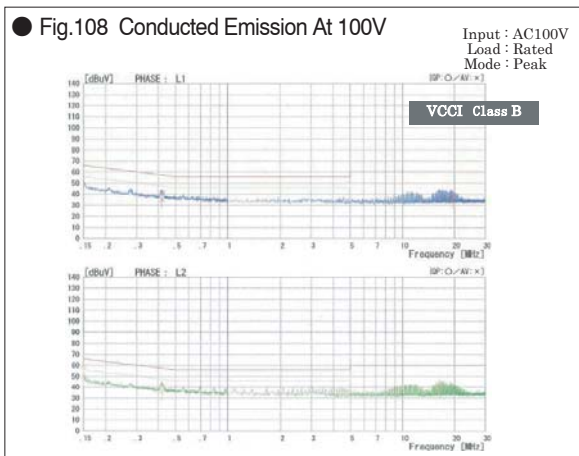
G. INDEX

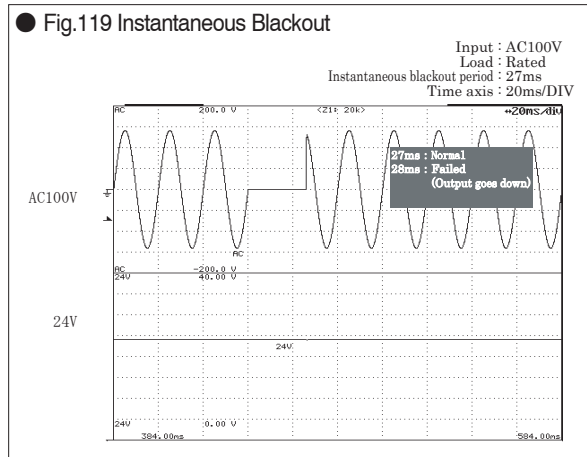
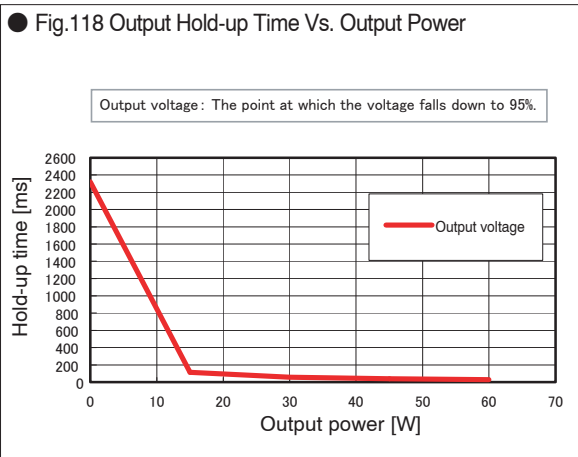
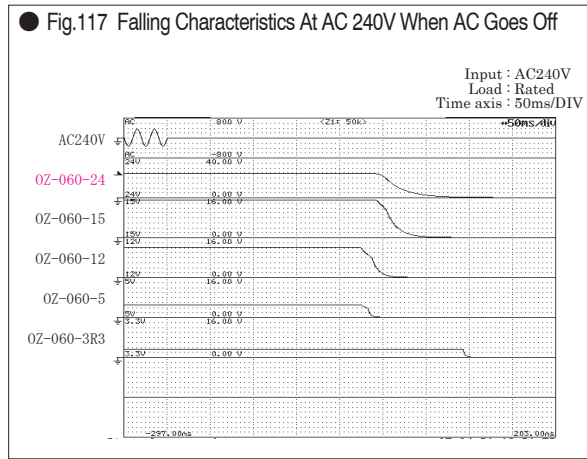
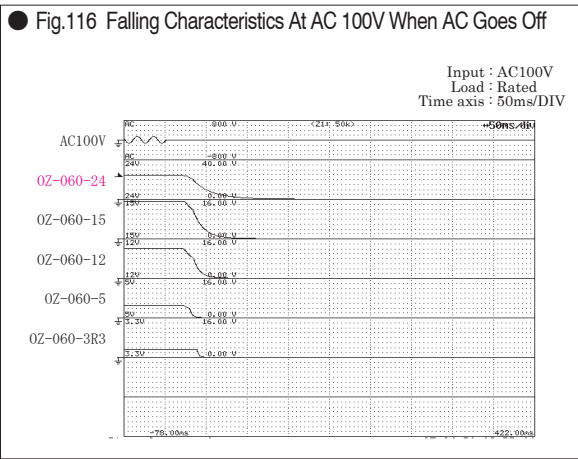
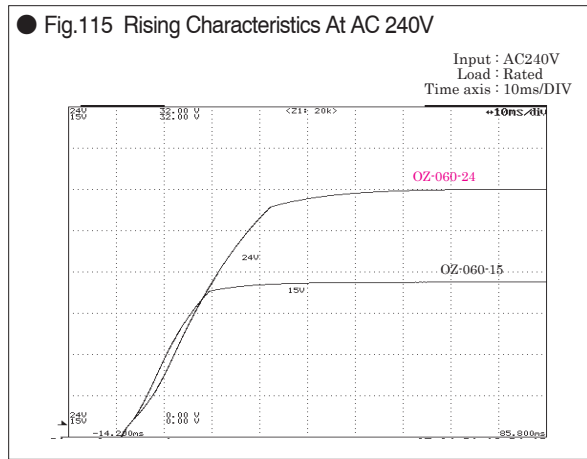
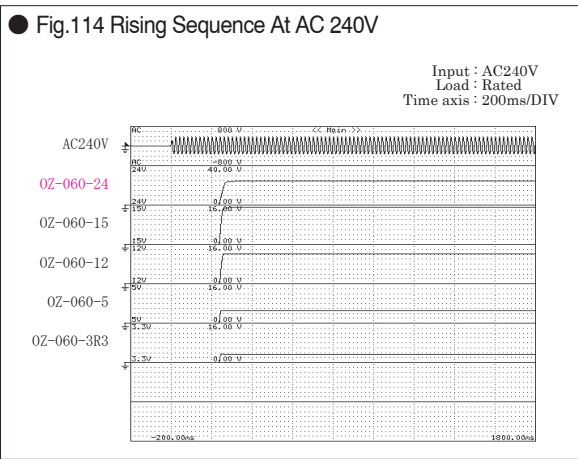
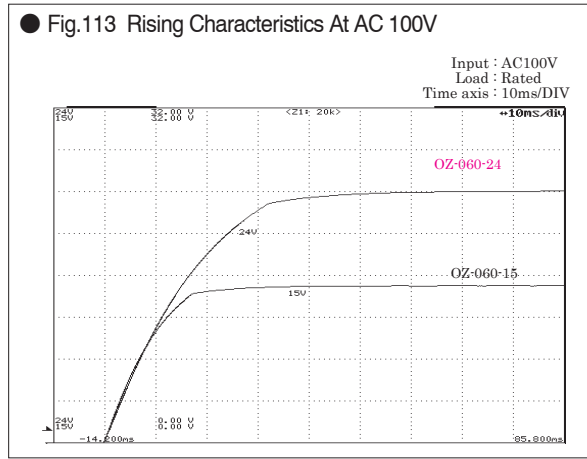
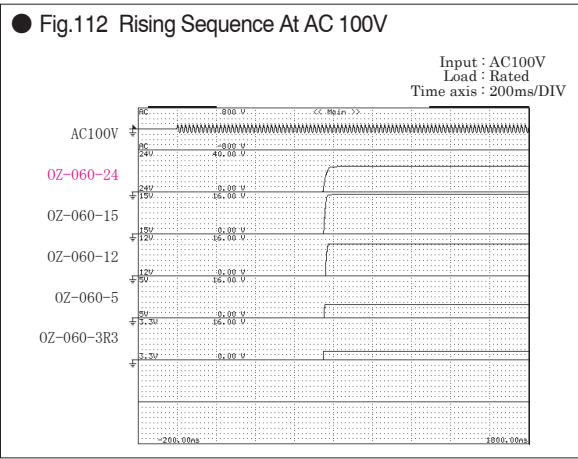


● Fig.107 Leakage Current

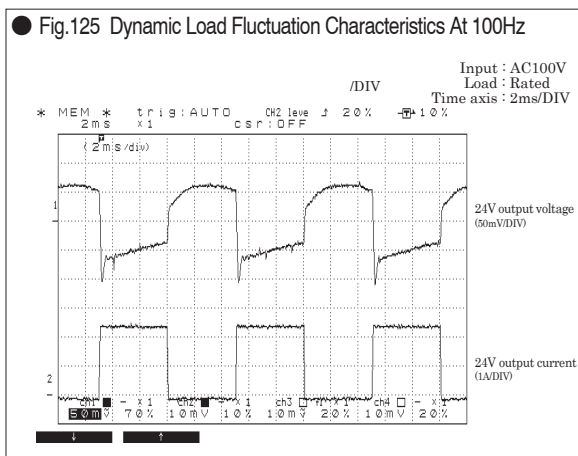
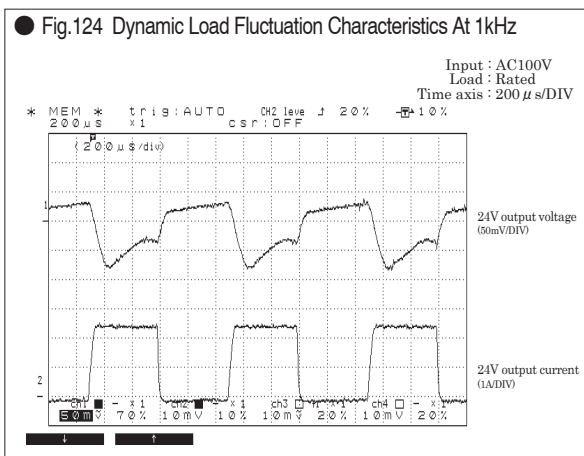
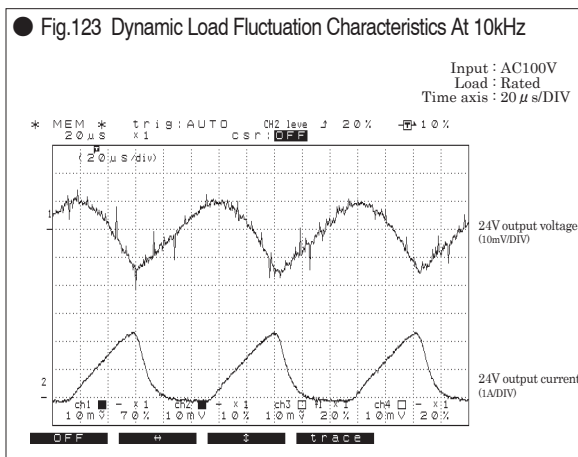
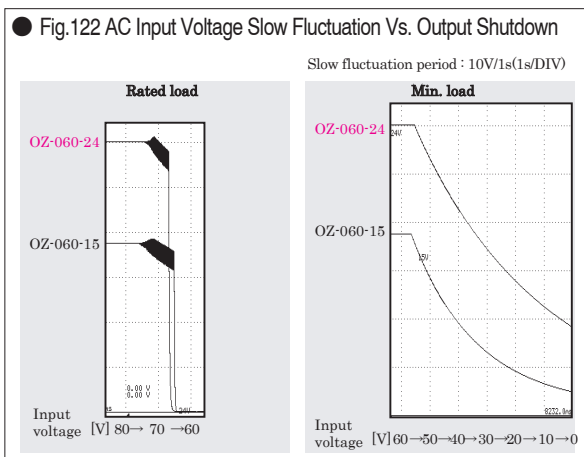
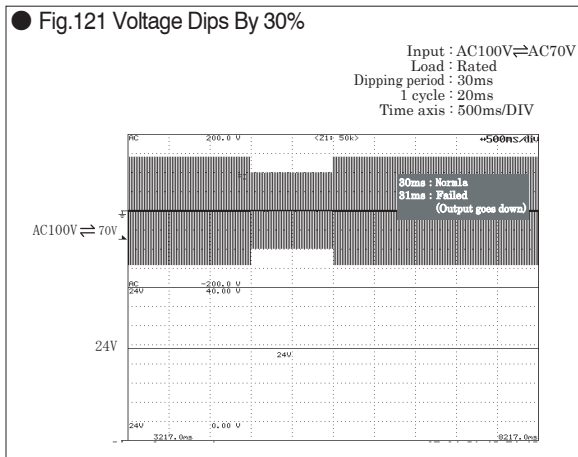
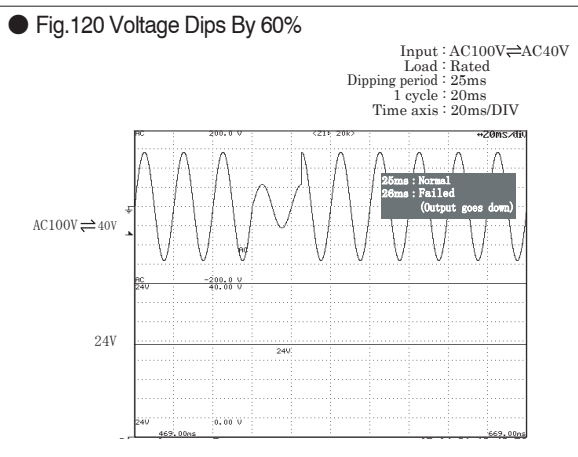
Input : AC 100, 200, 240V  
Load : Rated load and Min. load

	Rated load	Min. load
AC 100V	0.2mA	0.19mA
AC 200V	0.41mA	0.41mA
AC 240V	0.48mA	0.5mA





- Computer Power Supply - BRAIN
- B-A SELECTION GUIDE
  - B-B PRODUCT PAGE GUIDELINE
  - B-C NONSTOP POWER SUPPLY
  - B-D AC+DC DUAL-INPUT PSU
  - B-E GENERAL PURPOSE PC PSU
  - B-F GENERAL PURPOSE REDUNDANT PSU
  - B-G OPTIONS
- Control & Mechanism System Power Supply - LIMBS
- C-A SELECTION GUIDE
  - C-B PRODUCT PAGE GUIDELINE
  - C-C AC-DC SINGLE OUTPUT NONSTOP PSU
  - C-D AC-DC MULTI-OUTPUT NONSTOP PSU
  - C-E AC-DC SINGLE OUTPUT POWER SUPPLY
  - C-F AC-DC MULTI-OUTPUT POWER SUPPLY
  - C-G DC-DC CONVERTER
  - C-H OPTIONS

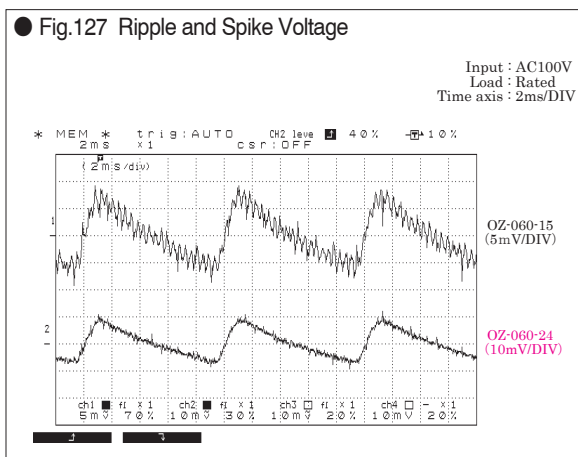


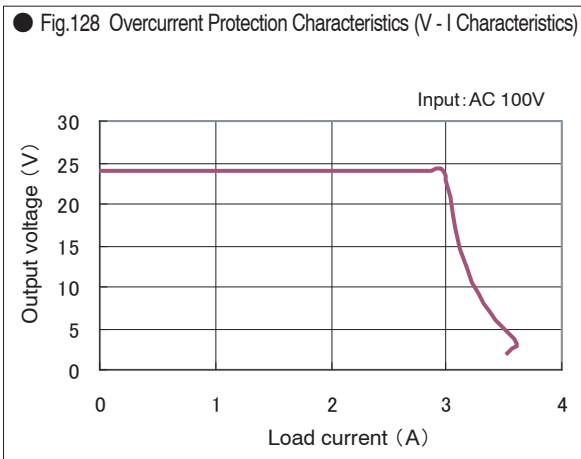
**Fig.126 Output Voltage Regulation**

Spec.	Min. load	Rated load
24V load	0A	2.5A

AC input	AC 85V	AC 100V	AC 132V	AC 176V	AC 240V	AC 264V
24V Output (Min.)	24.064 V	24.063 V	24.063 V	24.062 V	24.060 V	24.059 V
24V Output (50%)	24.060 V	24.059 V	24.060 V	24.059 V	24.058 V	24.057 V
24V Output (Rated)	24.058 V	24.058 V	24.058 V	24.057 V	24.055 V	24.055 V





Column 33

### Single output power supply with power failure signal

Measures against blackout has become critical not only at server systems but also at terminal equipments that need to send data of operation process in real time as network of production line has increased due to Information Technology.

Reponding to this demand, our OZP series power supply is designed to add bakcup function at blackout. In addition, AC FAIL signal to notify blackout is equipped as standard.

A. UPDATE

Computer Power Supply - BRAIN

- B.-A. SELECTION GUIDE
- B.-B. PRODUCT PAGE GUIDELINE
- B.-C. NONSTOP POWER SUPPLY
- B.-D. AC+DC DUAL-INPUT PSU
- B.-E. GENERAL PURPOSE PC PSU
- B.-F. GENERAL PURPOSE REDUNDANT PSU
- B.-G. OPTIONS

Control & Mechanism System Power Supply - LIMBS

- C.-A. SELECTION GUIDE
- C.-B. PRODUCT PAGE GUIDELINE
- C.-C. AC-DC SINGLE OUTPUT NONSTOP PSU
- C.-D. AC-DC MULTI-OUTPUT NONSTOP PSU
- C.-E. AC-DC SINGLE OUTPUT POWER SUPPLY
- C.-F. AC-DC MULTI-OUTPUT POWER SUPPLY
- C.-G. DC-DC CONVERTER
- C.-H. OPTIONS

D. TECHNICAL DICTIONARY

E. COMPANY PROFILE

F. BUSINESS MANUAL

G. INDEX