

# Desktop PC Power Supply NSP2-375-F4S

**ATX power supply and +24V power supply are combined !**  
**Nonstop power supply with 24V output**



NSP2-375-F4S

<b>ATX / Baby AT</b>	
<b>NSP</b> (nonstop power supply)	
<b>Continuous Max</b>	<b>Peak Power</b>
<b>350W</b>	<b>380W</b>

Model	Description	Stock	Standard Price (Before Tax)
NSP2-375-F4S		1 to 5 units:30 days before delivery, 6 units or more:100 days before delivery	¥50,000

**Model name coding**  
**NSP2 - 375 - F 4 S**

① Series name      ④ DC input voltage (battery voltage) 48V type  
 ② Output power      ⑤ Standard  
 ③ +24V output equipped

**Features**

- +24V output is added to ATX power supply
- Saves space and cost with brain supply (ATX) suitable for mechatronics and mechanism system power supply (+24V) combined.
- Each of +3.3V, +5V, and +12V and independent stabilizing circuit.
- BabyAT size
- DC48V startup is possible. The unit can be used as a DC input power supply other than for backup use (simultaneous input of AC and DC is possible).
- Since DC input circuit is independent from the GND the unit can be used in various environment.

Refer to "Product Page Guideline" on page B-B1 for icons.

Acquired safety standard	UL	CSA	EN	CE	CCC
Reliability Grade	HFA	FA	HOA	OA	

● **Function**

DC start  
  RS 232C  
  USB  
  TTL  
  PFC  
  Silence  
  5VSB FAN  
  TSFC FAN  
  Connection  
  Fit for Peak  
  Anti Disturb

● **Automatic shutdown compliant OS**

Windows 95/98  
  Windows NT  
  Windows 2000  
  Windows XP  
  Windows Vista

※See D-29 "power supply monitoring software" for details of automatic shutdown.  
 ※Refer to D-45「Q96J」for Linux

● **Input**

AC input	85V to 264V (worldwide range)
DC input	48V (battery connection and DC startup possible)

※Battery package is optional (sold separately). (Two units are needed.)

● **Output**

Output voltage	+3.3V	+5V	+12V	+24V	-5V	-12V	+5VSB
Max current/ max power (continuous)	8A	15A	8A	6A	0.5A	0.5A	1A
	Total 354.9W						
Peak current/ peak power (5s max)	14A	25A	12A	10A	0.5A	0.5A	1A
	Total 125W						
	Total 364W						
	Total 377.5W						
Minimum current	0A	2A 3A*	0A	0A	0A	0A	0A

\*At DC input

● **Dimensions**

W × H × D (mm)	165 × 150 × 150 (Baby AT size)
----------------	--------------------------------

● **Output connector**

20 Pin  
  24 Pin  
  AT  
  12V  
  AUX  
  Processor  
  SATA  
  PCI-E

# General Specification (Items are provided at normal temperature and humidity unless otherwise specified)

	Page	Items	Specification	Measurement conditions, etc.
AC Input	D-6(1)	Rated voltage	AC100-240V(AC85-264V) <a href="#">Characteristic data (B-C89 Fig.10-11)</a> *At DC operation, the unit can be used with DC40V to DC59V.	Worldwide range
	D-6(2)	Input frequency	50/60Hz	47-63Hz
	D-6(3)	Efficiency	70% typical (AC100V), 74% typical (AC240V) <a href="#">Characteristic data (B-C88 Fig.2)</a>	With rated input/output
	D-6(4)	Power factor	98% typical <a href="#">Characteristic data (B-C88 Fig.3)</a>	
	D-6(5)	Inrush current	50A peak(AC100V), 100A peak (AC240V) <a href="#">Characteristic data (B-C88 Fig.4)</a>	With rated output at cold start(25°C)
DC Input	D-6(6)	Input VA	600VA max <a href="#">Characteristic data (B-C88 Fig.3)</a>	
Output	D-6(1)	Rated voltage	DC48V (DC40 to 59V)	DC startup available
	D-6(7)	Battery discharge cut-off voltage	34V±2V max (shutdown of battery circuit)	
	D-6(8)	Efficiency	73% typical	With rated input/output
	—	Rated voltage	+3.3V +5V +12V +24V -5V -12V +5VSB	
	—	Rated current	8A 15A 8A 6A 0.5A 0.5A 1A	
	D-6(8)	Max current/power	8A 15A 8A 6A 0.5A 0.5A 1A	Max output power is 354.9W.
	D-6(9)	Peak current/power	14A 25A 12A 10A 0.5A 0.5A 1A 125W max 364W max	Peak output power is 377.5W. The time shall be 5s or less. For repetitive peak outputs, duty ratio shall be 5% or less (see <Fig.1>).
	D-6(10)	Minimum current	0A 2A 3A* 0A 0A 0A 0A	*At DC input
	D-6(11)	Total voltage accuracy (%)	±5 max ±5 max ±5 max ±10 max ±10 max ±10 max ±5 max	Sum of temperature, input, and load regulations.
	D-7(12)	Max ripple voltage (mVp-p)	50 max 50 max 100 max 200 max 50 max 100 max 50 max	Connect two wires to within 1mm from the output connector. Put a 0.1uF film capacitor and a 10uF electrolytic capacitor. Measure with a 20MHz oscilloscope. <a href="#">Characteristic data (B-C91 Fig.29)</a>
D-7(12)	Max spike voltage (mVp-p)	100 max 100 max 200 max 480 max 100 max 200 max 100 max		
Protection	D-7(13)	Over Current Protection	OCP point (A) 15 min* 22 min* 9 min 7 min Method All outputs shut down	Short circuit protection -5V and -12V outputs shut down All outputs shut down Other outputs have rated loads.* When other outputs do not have rated load, total current of +3.3V and +5V shall be 30A minimum.
	D-7(13)	Recovery (over current)	At AC operation	Reclosing input Automatic recovery of reclosing input Reclosing interval shall be 5s minimum.
			At battery operation	Reclosing input Automatic recovery of reclosing input
	D-7(14)	Over Voltage Protection	OVP point (V) 3.8 to 4.3 6.0 to 7.0 14 to 15.6 26.5 to 31.2 Method All outputs except for +5VSB shut down. All outputs shut down at DC operation.	
D-7(14)	Recovery (over voltage)	At AC operation	Reclosing input (reclosing interval shall be 5s min)	
		At battery operation	Reclosing input	
Charge Environment	—	Charge voltage	54V typical (At 25°C, with no load)	
	—	Charge current	0.5±0.2A (with 48V battery voltage)	
	D-7(16)	Operating temperature/humidity	0-50°C/10-90%	There shall be no condensation.
	D-7(17)	Storage temperature/humidity	-25-70°C/10-95%	There shall be no condensation.
D-7(18)	Vibration	Displacement amplitude of 0.15mm with a vibration frequency of 10-55Hz for 10 sweep cycles in the X-Y-Z directions for 45 minutes.	JIS-C-0040-1995	
D-7(19)	Mechanical shock	Acceleration of 150m/s <sup>2</sup> for 11ms one time each in the X, Y, Z directions. No malfunction, damage, loosening, or coming-off.	JIS-C-0041-1995	
Insulation	D-7(20)	Dielectric strength	AC 1500V for one minute between AC input and FG/DC output/DC input	
	D-7(21)	Insulation resistance	50MΩ min between AC input and DC output/FG/DC input	At DC500V
			50MΩ min between DC input—DC output—FG 50MΩ min between 24V output and DC output	
D-7(22)	Leakage current	0.5mA max (AC 100V)/1mA max (AC240V)	YEW. TYPE3226 (1kΩ) or equivalent	
EMS	D-7(23)	Line noise immunity	±2000V (pulse width: 100ns and 800ns, repetitive cycle: 10-50ms)	It shall follow the DC output specification. There shall be no malfunction.
	D-7(24)	Electrostatic discharge	EN61000-4-2 compliant	
	D-7(25)	Radiated, radio-frequency EM field	EN61000-4-3 compliant	
	D-7(26)	Fast transient burst	EN61000-4-4 compliant	
	D-7(27)	Lightning surge	EN61000-4-5 compliant	
	D-7(28)	Conducted disturbances induced by radio-frequency	EN61000-4-6 compliant	
	D-7(29)	Power source frequency magnetic field	EN61000-4-8 compliant	
	D-8(30)	Voltage dip/regulation	EN61000-4-11 compliant <a href="#">Characteristic data (B-C90 Fig.22-23)</a>	
	D-8(31)	Conducted emission	VCCI-A, FCC-A, EN55022-A compliant	Measured with power supply single body, at rated output
	D-8(32)	Harmonic current regulation	IEC1000-3-2 Class A and EN61000-3-2 Class A compliant <a href="#">Characteristic data (B-C88 Fig.6-7)</a>	At rated input/output
Others	D-8(1-6)	Safety standard	UL60950 and EN60950 compliant	
	D-8(34)	Cooling system	Forced-air cooling	
	D-8(35)	Output GND terminal	Capacitor grounding	
	D-8(38)	Output hold-up time	PWR_OK holds up 30ms min after AC failure <a href="#">Characteristic data (B-C90 Fig.20)</a>	At rated output
	F-3	Reliability Grade	FA (Industrial equipment grade, double-sided PWB with through holes)	It is to follow our standard.
	D-8(41)	MTBF	76,000H min	Based on EIAJ RCR-9102
—	Weight	3.2 kg typical		
F-3	Warranty	Three years after delivery, if any faults belong to us, the defective unit shall be repaired or replaced at our cost.	Except for errors caused by operation not listed.	

<Figure 1> Duty Ratio

Peak output current/power shall be 5s max continuously, for repetitive outputs, duty ratio shall be 5% or less.

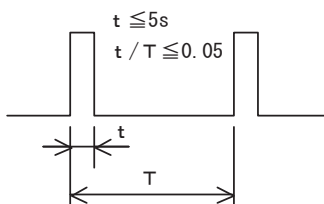

Computer Power Supply - BRAIN

Control & Mechanism System Power Supply - LIMBS

- A. UPDATE
- B. SELECTION GUIDE
- B. PRODUCT PAGE GUIDELINE
- B. NONSTOP POWER SUPPLY
- B. AC+DC DUAL-INPUT PSU
- B. GENERAL PURPOSE PC PSU
- B. GENERAL PURPOSE REDUNDANT PSU
- B. OPTIONS
- C. SELECTION GUIDE
- C. PRODUCT PAGE GUIDELINE
- C. AC-DC SINGLE OUTPUT NONSTOP PSU
- C. AC-DC MULTI-OUTPUT NONSTOP PSU
- C. AC-DC SINGLE OUTPUT POWER SUPPLY
- C. AC-DC MULTI-OUTPUT POWER SUPPLY
- C. DC-DC CONVERTER
- C. OPTIONS
- D. TECHNICAL DICTIONARY
- E. COMPANY PROFILE
- F. BUSINESS MANUAL
- G. INDEX

# Signal Input/Output Specification (Items are provided at normal temperature and humidity unless otherwise specified.)

Items	Specification	Note
<b>Input Signal</b>		
Output ON/OFF control signal (PS_ON#)	With 'H' or 'OPEN' input, +3.3V, +5V, +12V, -5V, and -12V outputs shut down. At backup operation (DC), battery connection (DC) shuts down with 'H' or 'OPEN' input.	Signal input between P1 connector 14-pin and COM pin
Battery shutdown signal for TTL (SHUT_DOWN_T)	Battery connection is shut down with 'L' input. This function is only available during backup (DC) operation.	Signal input between P15 connector 2-pin and COM-pin
Battery shutdown signal for RS232C (SHUT_DOWN_R)	'Battery connection is shut down with 'positive' input. This function is only available during backup (DC) operation.	Front panel RS232C connector 4-pin
Operation shifting control (BATT_CHECK)	'At 'L' input, AC inverter is forcibly shut down, and it will be switched to battery (DC) operation to make pseudo blackout.	Signal input between P15 connector 5-pin and COM pin
<b>Output Signal</b>		
Normal output signal (PWR_OK)	When +5V output is normal, 'H' is delivered (detection delay time: 200 to 350ms).	P1 connector 8-pin
Blackout detection signal for TTL (AC_FAIL_T)	The signal goes 'OPEN' at low AC input voltage and blackout detection (open collector output) (detection delay time: 200 to 350ms).	P15 connector 3-pin
Blackout detection signal for RS232C (AC_FAIL_R)	'Negative (-11V typical)' is delivered at low AC input voltage and blackout detection (detection voltage: AC80V typical, detection delay time: 20 to 40ms after AC failure)	Front panel RS232C connector 8-pin
Low battery voltage signal for TTL (BATT_LOW_T)	'OPEN' is delivered when the battery terminal voltage decreases to 40±1V (open collector output). 'L' is delivered if the battery package is not connected.	P15 connector 4-pin
Low battery voltage signal for RS232C (BATT_LOW_R)	'Negative (-11V typical)' is delivered when the battery terminal voltage decreases to 40±1V. 'Positive (+11V typical)' is delivered if the battery package is not connected.	Front panel RS232C connector 1-pin
Fan alarm signal (FAN_ALARM)	When the fan lock status remains, square waves are delivered as shown below.	P15 connector 6-pin

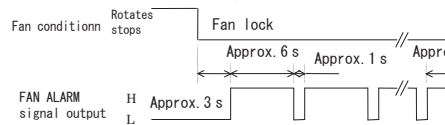

### Signal Circuit

<b>Input Signal Circuit</b>	(PS_ON#), (SHUT_DOWN_T), (BATT_CHECK)	(SHUT_DOWN_R)	
<b>Output Signal Circuit</b>	(PWR_OK)	(AC_FAIL_T), (FAN_ALARM), (BATT_LOW_T)	(AC_FAIL_R), (BATT_LOW_R)

### Interior View



# Power Supply Timing (Provided that a dedicated battery package is connected to NSP2-375-F4S.)

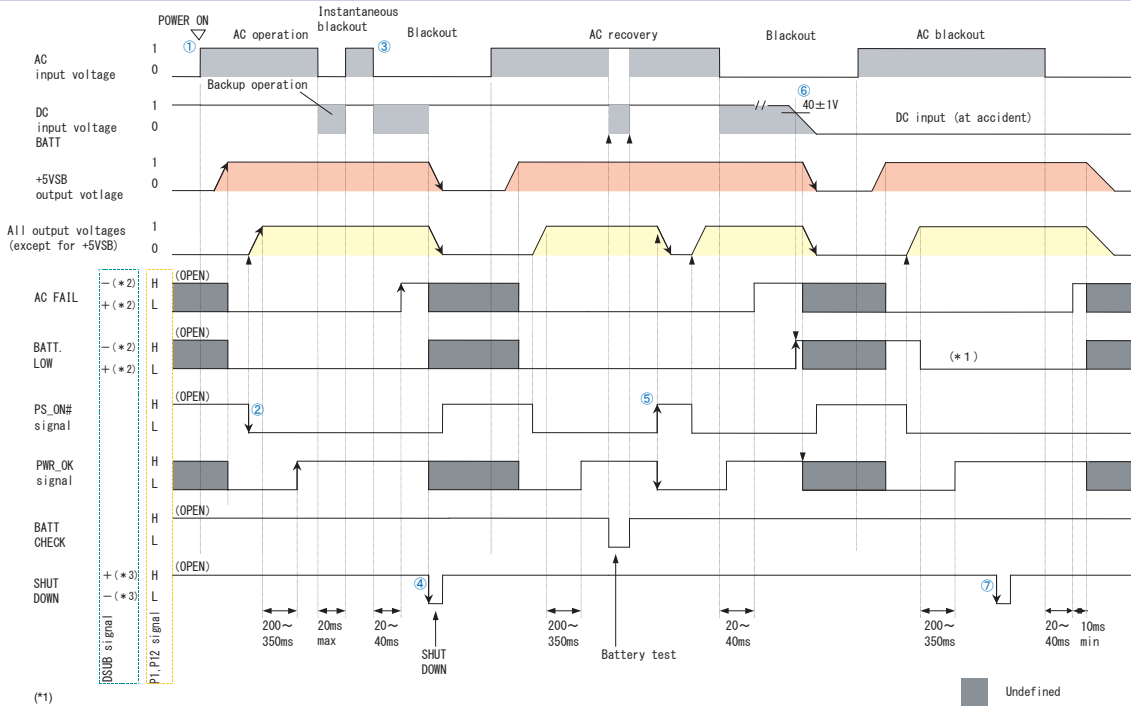

- (\*)1 Due to charger output, BATT.LOW is not delivered.
- (\*)2 Negative signal output shall be -11V typical. Positive signal output shall be +11V typical.
- (\*)3 Negative signal input shall be +0.4V to -30V. Positive signal input shall be +2.8V to +30V.

- ① With AC input, only +5VSB starts up.
- ② With PS\_ON# 'L' input, all outputs start up. After 200 to 350ms, PWR\_OK 'H' is delivered.
- ③ AC FAIL 'negative (RS232C)' or 'H (OPEN)(TTL)' is delivered 20 to 40ms after blackout.
- ④ At blackout, all outputs including 5VSB shut down with SHUT DOWN 'positive (RS232C)' or 'L (TTL)' input.
- ⑤ When AC input and all outputs including 5VSB start up, all outputs except for 5VSB shut down with PS\_ON# 'H (OPEN)' input.
- ⑥ When the battery voltage decreases to  $40 \pm 1V$  or less at backup operation, BATT LOW 'negative (RS232C)' or 'H (OPEN) (TTL)' is delivered; after it decreases to  $34 \pm 2V$  or less, all outputs, including 5VSB shut down.
- ⑦ At AC input, the output does not change with SHUT DOWN 'positive (RS232C)' or 'L (TTL)' input.

## Block Diagram

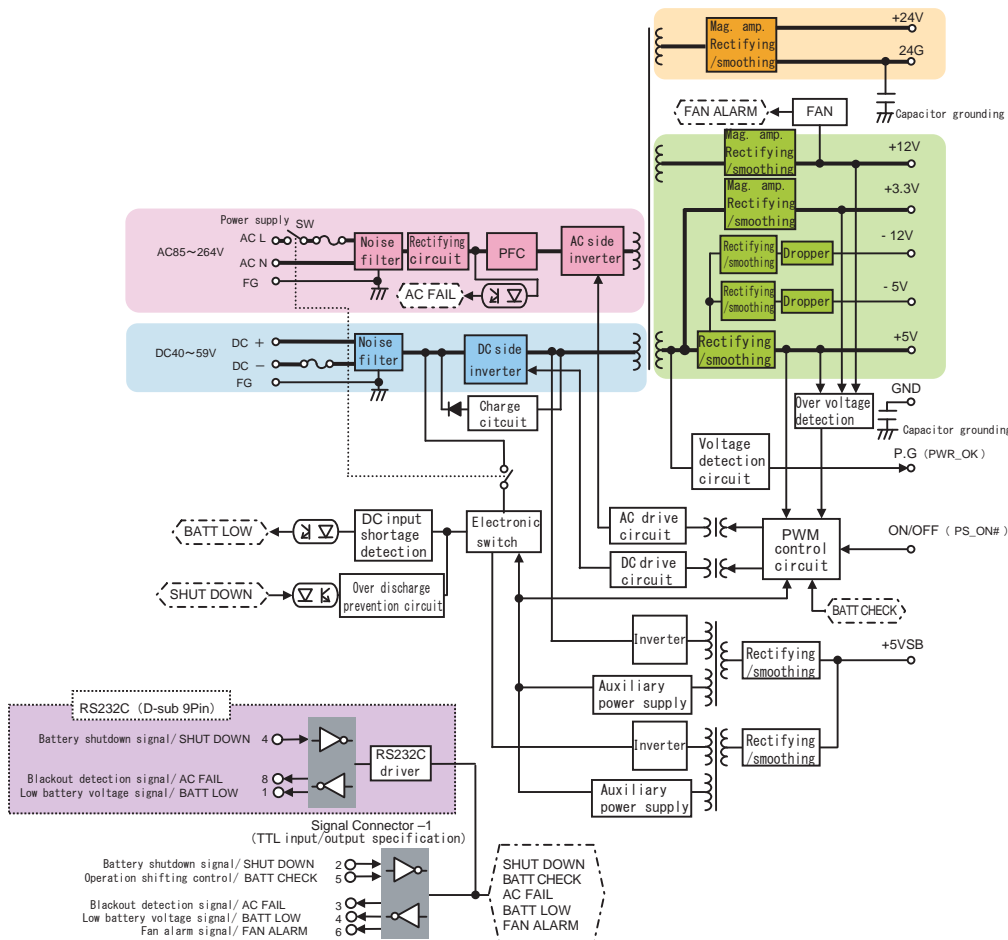

A. UPDATE

Computer Power Supply - BRAIN

B. SELECTION GUIDE

B. PRODUCT PAGE GUIDELINE

B. NONSTOP POWER SUPPLY

B. AC+DC DUAL-INPUT PSU

B. GENERAL PURPOSE PC PSU

B. GENERAL PURPOSE REDUNDANT PSU

B. OPTIONS

Control & Mechanism System Power Supply - LIMBS

C. SELECTION GUIDE

C. PRODUCT PAGE GUIDELINE

C. AC-DC SINGLE OUTPUT NONSTOP PSU

C. AC-DC MULTI-OUTPUT NONSTOP PSU

C. AC-DC SINGLE OUTPUT POWER SUPPLY

C. AC-DC MULTI-OUTPUT POWER SUPPLY

C. DC-DC CONVERTER

C. OPTIONS

D. TECHNICAL DICTIONARY

E. COMPANY PROFILE

F. BUSINESS MANUAL

G. INDEX

# Outline Drawing

Computer Power Supply - BRAIN

Control & Mechanism System Power Supply - LIMBS

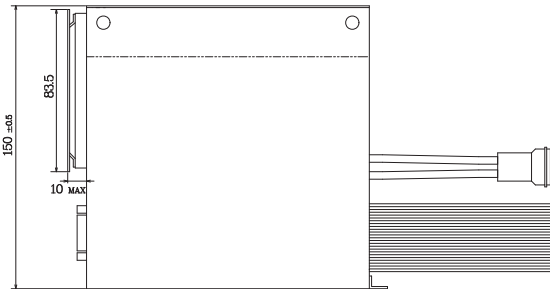
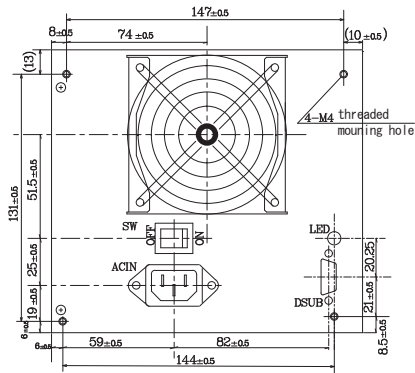
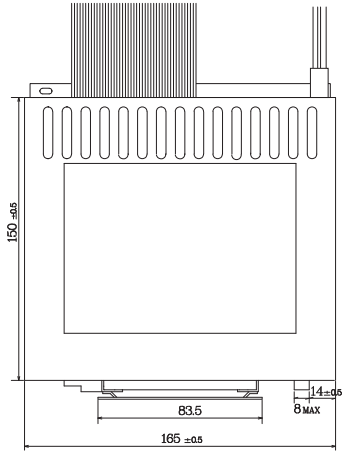

Note: The depth of mounting screws inside the power supply shall be 4mm max.

# Output Harness

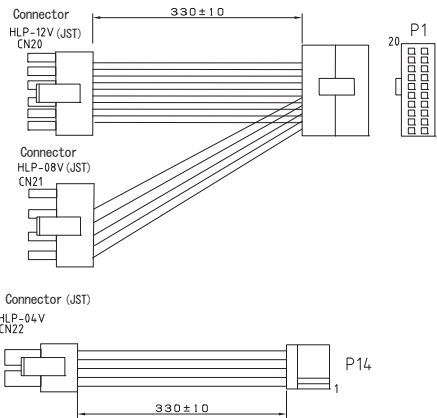

CONTACT	Harness NAME	PIN NO.	CN NAME	PIN NO.	FUNCTION	COLOR	WIRE TYPE	UL1007	CONTACT	CONNECTOR TYPE
SSF-21T-P14	CN20	1	P1	1	+3.3VDC	BROWN	AWG#18	RC16M-23D28	Housing 555T-20R(Molex) Terminal 5556 (Molex)	
		2		COM	2	+3.3VDC				BROWN
		3		COM	3	+5VDC				RED
		4		+5VDC	RED					
	CN21	5	COM	5	COM	BLACK	AWG#22	RC20M-12D28		
		6	+5VDC	RED						
		7	COM	7	COM	BLACK				
		8	+5VDC	RED						
	CN20	9	P14	9	+5VDC	YELLOW	AWG#22	RC20M-12D28		
		10		+12VDC	YELLOW					
		11		+3.3VDC	BROWN					
		12		+5VDC	RED					
	CN21	13	P14	13	COM	BLACK	AWG#22	RC20M-12D28		
		14		ON/OFF	VIOLET					
15		COM		BLACK						
16		COM		BLACK						
CN20	17	P14	17	COM	BLACK	AWG#18	RC16M-23D28			
	18		+5V	WHITE						
	19		+5VDC	RED						
	20		+5VDC	RED						
CN22	1	P14	1	+5VDC	RED	AWG#22	RC20M-12D28	Housing 51630-0630(Molex) Terminal 51630-0630(Molex)		
	2		COM	BLACK						
	3		COM	BLACK						
	4		+12VDC	YELLOW						

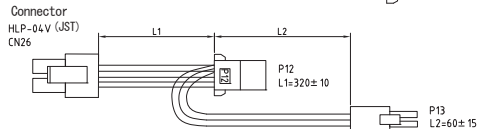
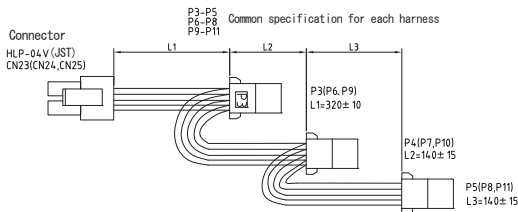
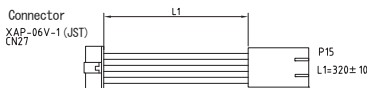

CONTACT	Harness NAME	PIN NO.	CN NAME	PIN NO.	FUNCTION	COLOR	WIRE TYPE	UL1007	CONTACT	CONNECTOR TYPE
SSF-21T-P14	CN23	1	P12	1	+12VDC	YELLOW	AWG#18	UL1007	Housing LCP-04(JST) Terminal 17182Z-4(IAMP)	
		2		COM	2	COM				BLACK
		3		COM	3	COM				BLACK
		4		+5VDC	RED					
SXA-001T-P0.6	CN27	1	P15	1	+12VDC	YELLOW	AWG#22	UL1007	Housing 51630-0630(Molex) Terminal 50084-8114(Molex)	
		2		COM	2	SHUTDOWN				YELLOW
		3		AC FAIL	3	BATT LOW				BLUE
		4		BATT LOW	WHITE					
5	BATT CHECK	ORANGE								
6	FAN ALM	VIOLET								

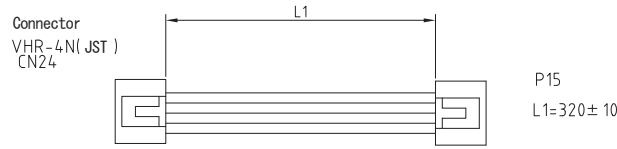

CONTACT	Harness NAME	PIN NO	FUNCTION	CN NAME	PIN NO	FUNCTION	WIRE		CONNECTOR TYPE
							COLOR	TYPE	
SVH-21T-P1.1	CN24	1	+24VDC	P3	1	+24VDC	ORANGE	UL1007 AWG#18	Housing VHR-4N(JST) Terminal SVH-21T-P1.1(JST)
		2	+24VDC		ORANGE				
		3	+24VGND		BLACK				
		4	+24VGND		BLACK				

Optional Components (Sold separately)

Battery package					
Page	Picture	Model	Battery type	Shape (size)	Backup time
B-62		BS05A-P24/2. 2L	Lead	5-inch bay fixed type (W × D × H = 146 × 190 × 37mm)	
B-64		RBS01A-P24/2. 2L	Lead	5-inch bay fixed, removable type (W × D × H = 146 × 245 × 42mm)	

※The backup time is a reference value at initial use; it is not a guaranteed value.  
 ※NSP2-375-F4S needs two battery packages (serial connection).

Cable				
Page	Picture	Model	Type	Description
B-646		WH2601-01	RS232C communication cable	Dedicated to Windows 95/98/NT
B-646		WH2601-02	RS232C communication cable	Dedicated to Windows 2000/XP/Vista 【RoHS】
B-646		WH2753	AC power cord	AC125V 12A 【PSE】

Software				
Page	Picture	Model	Type	Description
B-660		NSP Pro for 95/98	Automatic shutdown software	Dedicated to Windows 95/98. RS232C cables, WH2601-01 and WH2601-02 (accessories)
B-660		NSP Pro for NT	Automatic shutdown software	Dedicated to Windows NT RS232C cable, WH2601-01 (accessory)
B-660		NSP Pro 2	Automatic shutdown software	Dedicated to Windows 2000/XP/Vista RS232C cable, WH2601-02

※Windows 2000 and XP can be used with UPS service with standard OS. See D-44 "Nonstop power supply monitoring software" for more details of UPS service.

Other optional components					
Page	Model	Description	Page	Model	Description
B-652	ACC2637	Automatic startup unit	B-650	WH5105	12V 4-pin connector conversion harness (80mm)
B-649	WH2820	20-pin extension harness (600mm)	B-650	WH5105-02	12V 4-pin connector conversion harness (320mm)
B-649	WH2747	20-pin extension harness (450mm)	B-647	WH5055	AT connector conversion harness
B-649	WH2892-02	20-pin extension harness (200mm)	B-647	ACC5046	Harness with PS_ON switch
B-651	WH2812	PCI-E 6-pin connector conversion harness	B-648	ACC5077	PS_ON terminal short connector
			B-648	WH5073	PS_ON short terminal 20-pin harness

Computer Power Supply - BRAIN

Control & Mechanism System Power Supply - LIMBS

- A. UPDATE
- B-A. SELECTION GUIDE
- B-B. PRODUCT PAGE GUIDELINE
- B-C. NONSTOP POWER SUPPLY
- B-D. AC+DC DUAL-INPUT PSU
- B-E. GENERAL PURPOSE PC PSU
- B-F. GENERAL PURPOSE REDUNDANT PSU
- B-G. OPTIONS
- C-A. SELECTION GUIDE
- C-B. PRODUCT PAGE GUIDELINE
- C-C. AC-DC SINGLE OUTPUT NONSTOP PSU
- C-D. AC-DC MULTI-OUTPUT NONSTOP PSU
- C-E. AC-DC SINGLE OUTPUT POWER SUPPLY
- C-F. AC-DC MULTI-OUTPUT POWER SUPPLY
- C-G. DC-DC CONVERTER
- C-H. OPTIONS
- D. TECHNICAL DICTIONARY
- E. COMPANY PROFILE
- F. BUSINESS MANUAL
- G. INDEX

● Fig.2 Efficiency/Input Current Vs. Output Power

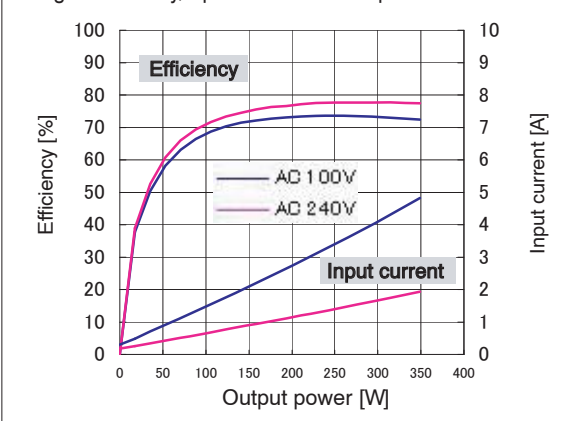

● Fig.3 Power Factor/Input VA Vs. Output Power

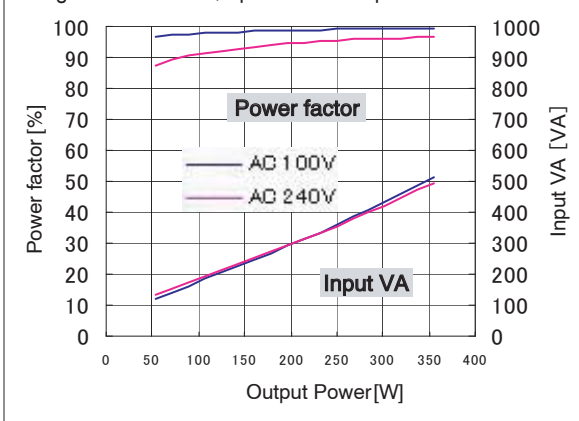

● Fig.4 Inrush Current

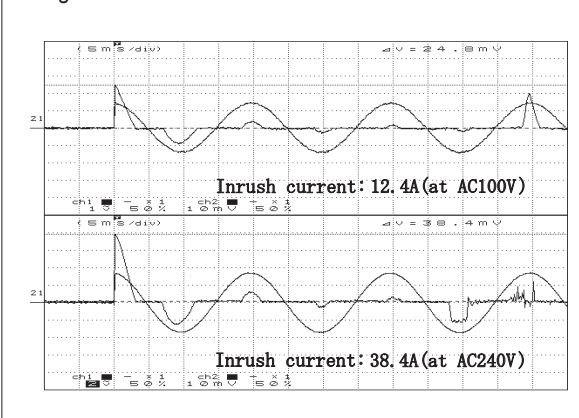

● Fig.5 Leakage Current

Input : AC 100, 240V  
Load : Rated load, Min. load

	Rated load	Min. load
AC 100V	0.33mA	0.36mA
AC 240V	0.69mA	0.73mA

● Fig.6 Harmonic Current At AC 100V

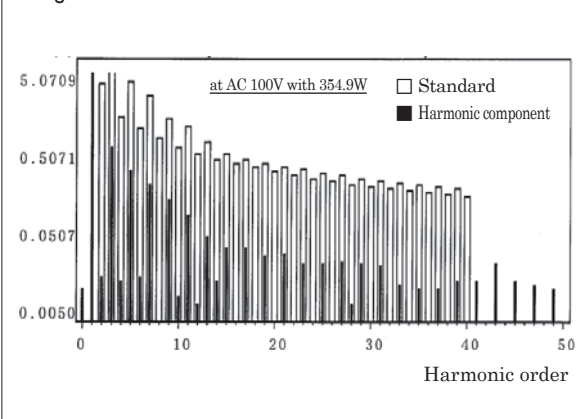

● Fig.7 Harmonic Current At AC 240V

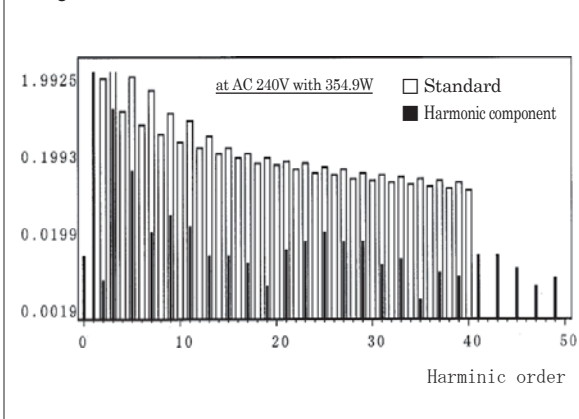

● Fig.8 Conducted Emission At 100V

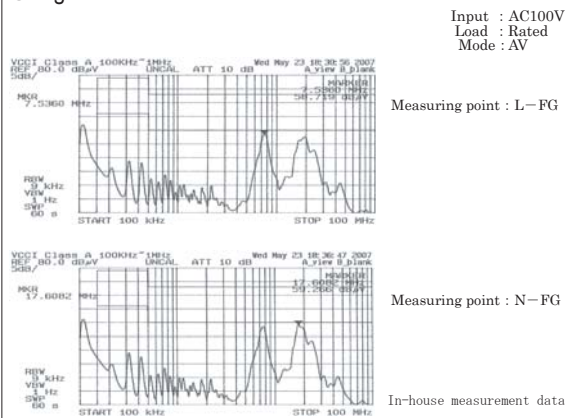

● Fig.9 Conducted Emission At 240V

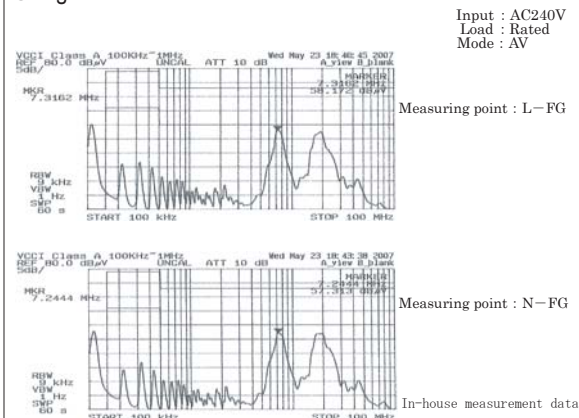

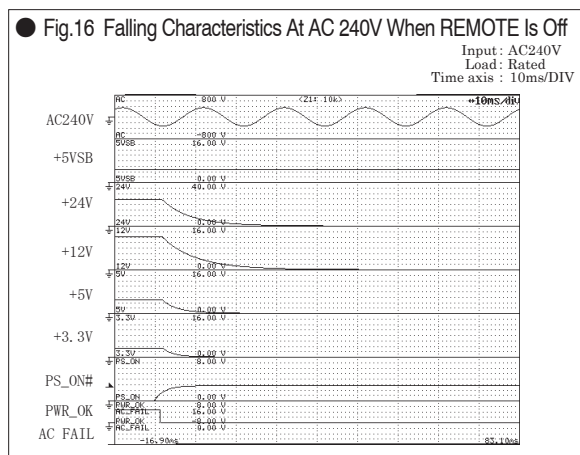
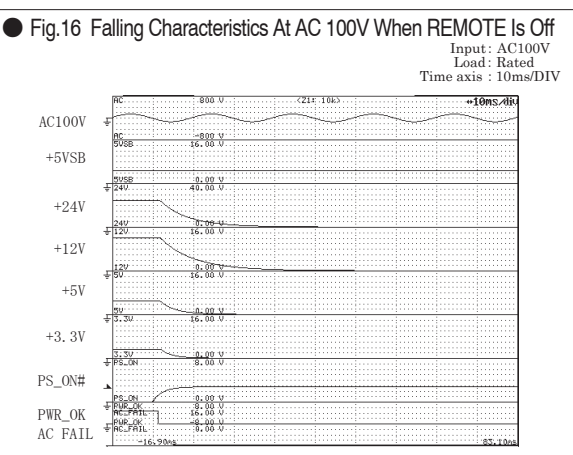
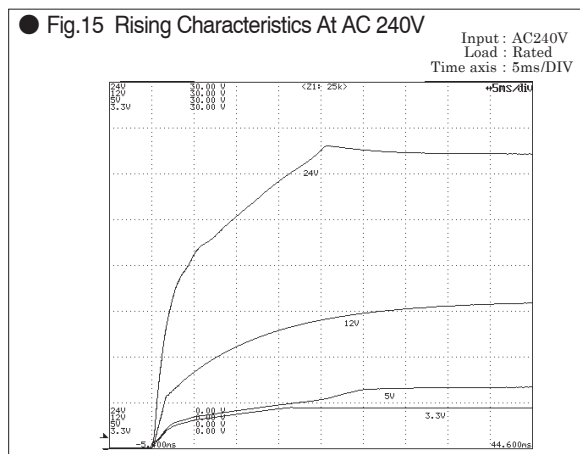
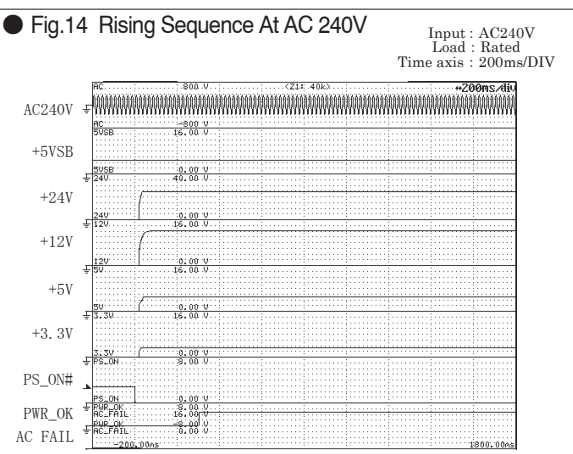
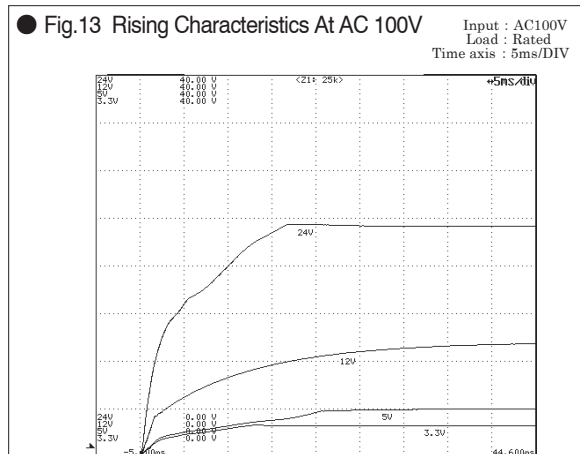
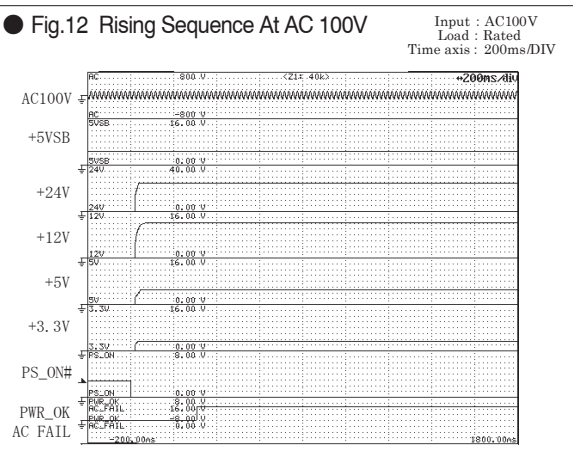
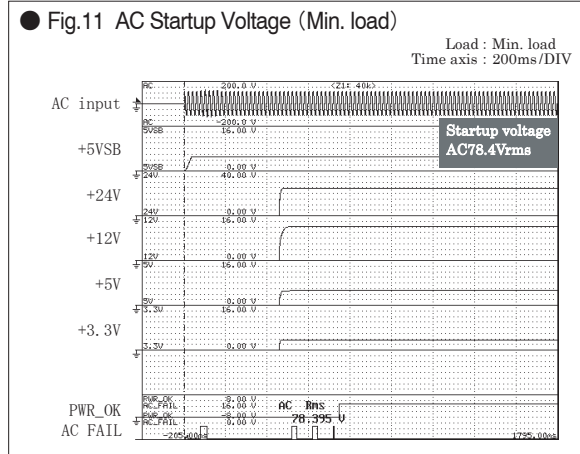
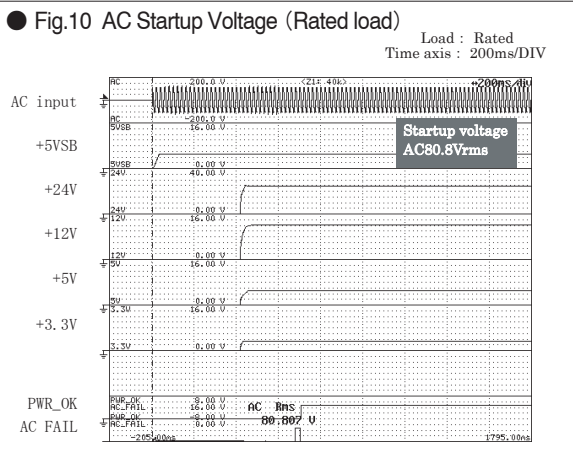

Computer Power Supply - BRAIN

Control & Mechanism System Power Supply - LIMBS

**C** Characteristic Data (Examples of actual measurement)

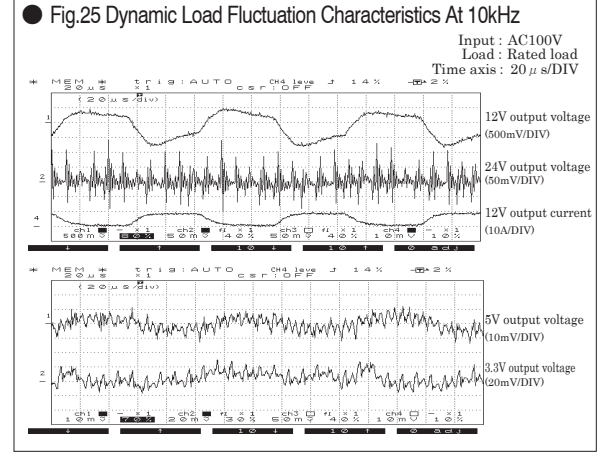
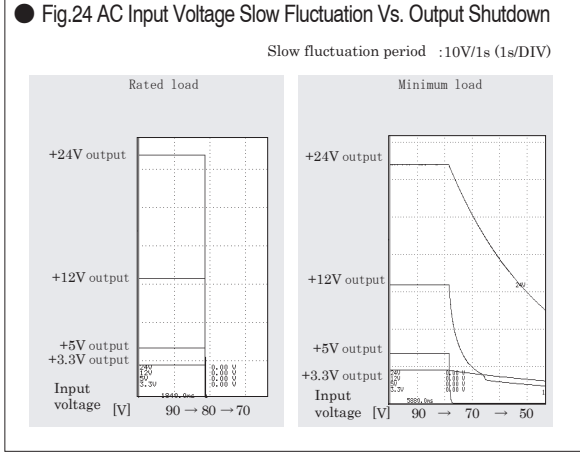
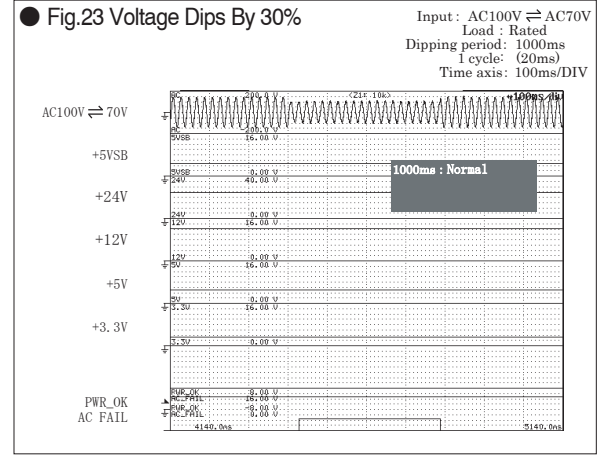
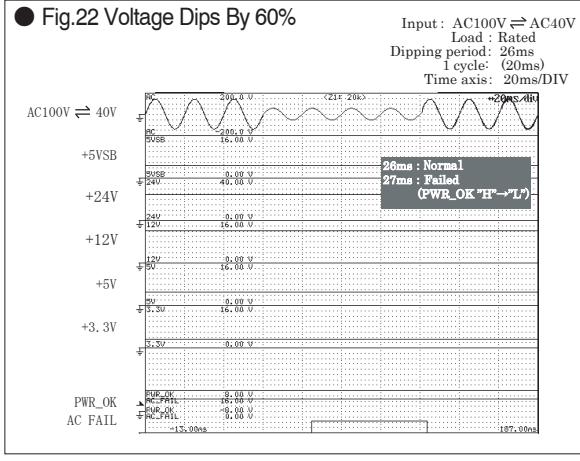
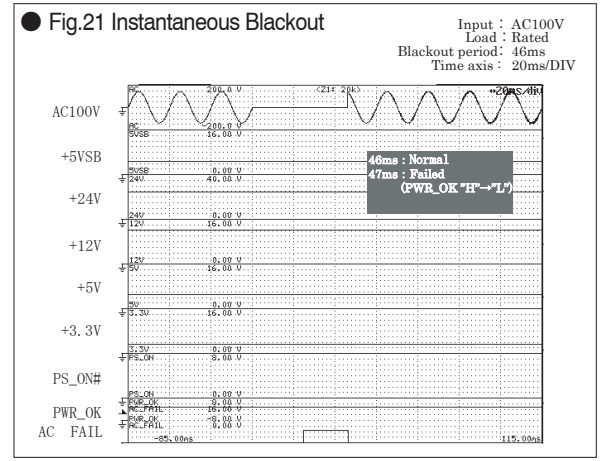
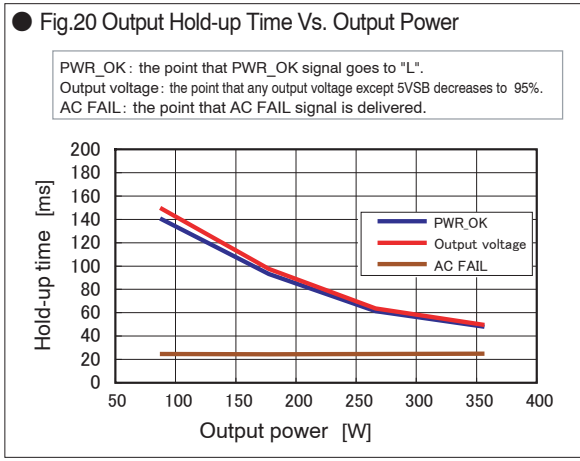
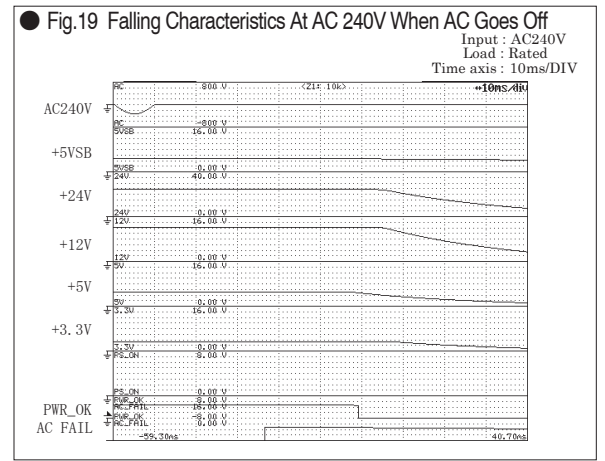
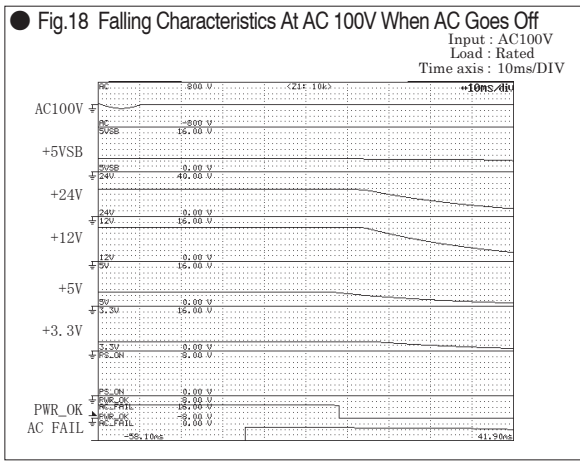

# Characteristic Data (Examples of actual measurement)

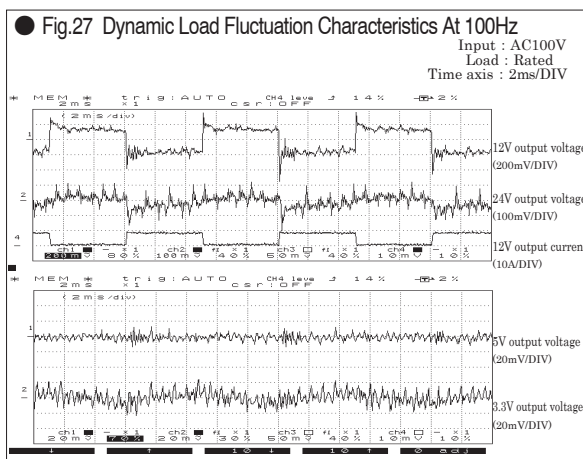
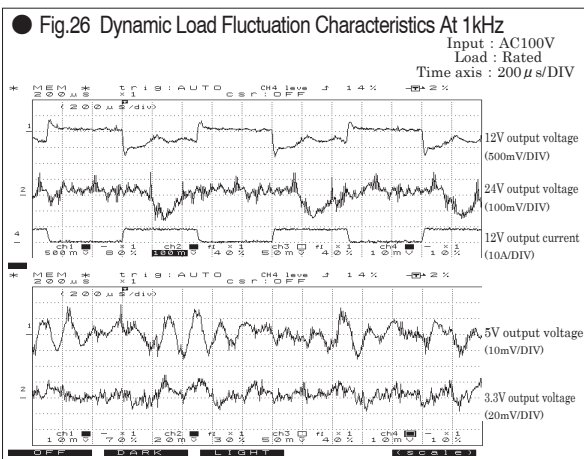

**Fig.28 Output Voltage Regulation**

Output	Min. load	Rated load	Peak load
12V output	0A	8A	16A
24V output	0A	6A	10A
5V output	2A	15A	25A
3.3V output	0A	8A	14A

AC input	AC 85V	AC 100V	AC 132V	AC 176V	AC 240V	AC 264V
12V output (min)	12.218 V	12.216 V	12.216 V	12.218 V	12.218 V	12.218 V
12V output (rated)	11.872 V	11.877 V	11.884 V	11.888 V	11.887 V	11.887 V
12V output (peak)	11.716 V	11.710 V	11.717 V	11.712 V	11.696 V	11.696 V
24V output (min)	24.281 V	24.281 V	24.284 V	24.279 V	24.280 V	24.280 V
24V output (rated)	24.132 V	24.132 V	24.132 V	24.131 V	24.133 V	24.133 V
24V output (peak)	24.034 V	24.034 V	24.032 V	24.034 V	24.035 V	24.035 V
5V output (min)	5.136 V	5.134 V	5.134 V	5.134 V	5.134 V	5.134 V
5V output (rated)	5.021 V	5.021 V	5.021 V	5.021 V	5.021 V	5.021 V
5V output (peak)	4.980 V	4.980 V	4.981 V	4.981 V	4.981 V	4.981 V
3.3V output (min)	3.365 V	3.365 V	3.364 V	3.364 V	3.364 V	3.364 V
3.3V output (rated)	3.296 V	3.295 V	3.293 V	3.292 V	3.292 V	3.292 V
3.3V output (peak)	3.254 V	3.253 V	3.251 V	3.251 V	3.251 V	3.251 V

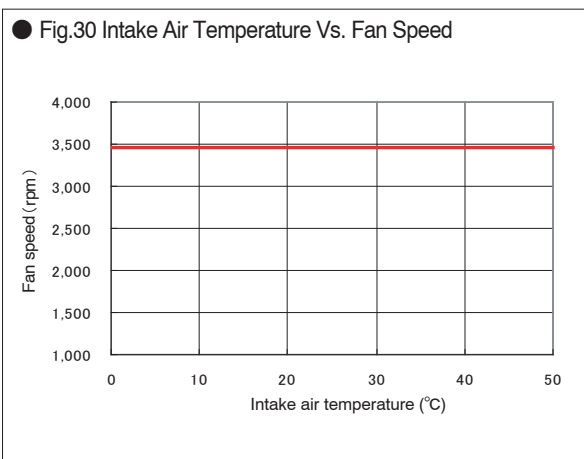
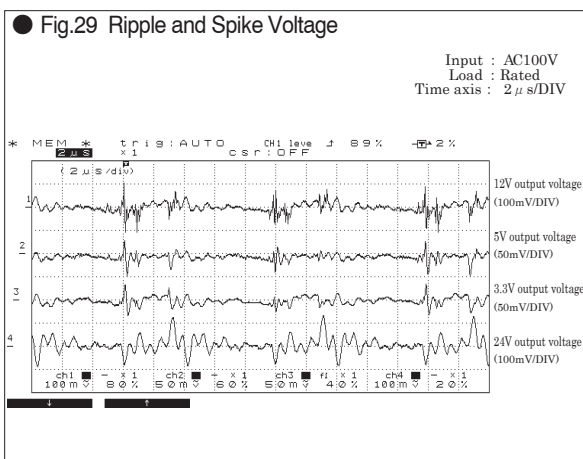

**Computer Power Supply - BRAIN**

- A. UPDATE
- B. SELECTION GUIDE
  - B. A. PRODUCT PAGE GUIDELINE
  - B. B. NONSTOP POWER SUPPLY
  - B. C. AC+DC DUAL-INPUT PSU
  - B. D. GENERAL PURPOSE PC PSU
  - B. E. GENERAL PURPOSE REDUNDANT PSU
  - B. F. OPTIONS
- C. SELECTION GUIDE
  - C. A. PRODUCT PAGE GUIDELINE
  - C. B. AC-DC SINGLE OUTPUT NONSTOP PSU
  - C. C. AC-DC MULTI-OUTPUT NONSTOP PSU
  - C. D. AC-DC SINGLE OUTPUT POWER SUPPLY
  - C. E. AC-DC MULTI-OUTPUT POWER SUPPLY
  - C. F. DC-DC CONVERTER
  - C. G. OPTIONS

**Control & Mechanism System Power Supply - LIMBS**

- D. TECHNICAL DICTIONARY
- E. COMPANY PROFILE
- F. BUSINESS MANUAL
- G. INDEX