

Desktop PC Power Supply NSP2-375-D4S

Nonstop power supply with DC startup ! Completely safe and uninterruptible operation with double input of AC+DC! The unit can be used as a DC input ATX power supply!



NSP2-375-D4S

ATX/Baby AT	
NSP (nonstop power supply)	
Continuous Max	Peak Power
350W	—

Model	Description	Stock	Standard Price (Before Tax)
NSP2-375-D4S		1 to 5 units:30 days before delivery. 6 units or more:100 days before delivery	¥46,000

Model name coding
NSP2 - 375 - D 4 S
 ① ② ③ ④ ⑤

① Series name ④ DC input voltage (battery voltage) 48V type
 ② Output power ⑤ Standard
 ③ D-sub terminal

※24V output type, NSP2-375-F4S, is on page B-C82.

Features

- DC startup is available.
- Since DC input is independent from the GND terminal, the unit can be used in various environment.
- Simultaneous input of DC48V and AC85 to 264 is suitable for important systems that require high reliability. Also, the unit can be operated continuously with DC48V input only.
- Each of +5V, +3.3V, and +12V inputs has a rated voltage control function. An external variable resistor is mounted.
- Dimensions are those of BabyAT.

Since DC input terminal is isolated, one external battery (lead) operate multiple units jointly (long-term continuous operation is possible). The battery can be shared with NSP2-250-D4S.

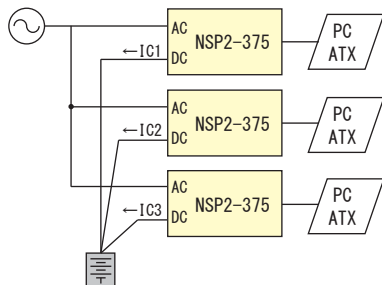

<Note> The battery receives charge current of (IC1~IC3)0.5±0.2A from each NSP2-375 power supply.

Refer to "Product Page Guideline" on page B-B1 for icons.

Acquired safety standard	UL	CSA	EN	CE	CCC
Reliability Grade	HFA	FA	HOA	OA	

Function

DC start	RS 232C	USB	TTL	PFC	Silence	5VSB FAN	TSFC FAN	Connection	Fit for Peak	Build Drains
----------	---------	-----	-----	-----	---------	----------	----------	------------	--------------	--------------

Automatic shutdown compliant OS

Windows 95/98	Windows NT	Windows 2000	Windows XP	Windows Vista
---------------	------------	--------------	------------	---------------

※See D-29 "power supply monitoring software" for details of automatic shutdown.
 ※Refer to page D-45 Q96 for Linux.

Input

AC input	85V to 264V (worldwide range)
DC input	48V (battery connection and DC startup possible)

※Battery package is optional (sold separately). (Two units are needed.)

Output

Output voltage	+3.3V	+5V	+12V	-5V	-12V	+5VSB
Max current/ max power (continuous)	20A	30A	13A	0.5A	0.5A	1A
	Total 193W					
	Total 337W					
	Total 350.3W					
minimum current	0A	3A	0A	0A	0A	0A

Dimensions

W × H × D (mm)	165 × 150 × 150 (Baby AT size)
----------------	--------------------------------

Output connector

20 Pin	24 Pin	AT	12V	AUX	Processor	x10	x1	S-ATA	PCI-E
--------	--------	----	-----	-----	-----------	-----	----	-------	-------

General Specification (Items are provided at normal temperature and humidity unless otherwise specified.)

	Page	Items	Specification	Measurement conditions, etc.		
AC Input	D-6(1)	Rated voltage	AC100-240V(AC85-264V) Characteristic data (B-C79 Fig.9-10)	World wide range		
	D-6(2)	Input frequency	50/60Hz	47-63Hz		
	D-6(3)	Efficiency	65% typical (AC100V), 71% typical (AC240V) Characteristic data (B-C78 Fig.1)	With rated input/output		
	D-6(4)	Power factor	98% typical Characteristic data (B-C78 Fig.2)			
	D-6(5)	Inrush current	50A peak(AC100V), 100A peak (AC240V) Characteristic data (B-C78 Fig.3)	With rate input/output at cold start (25°C)		
	D-6(6)	Input VA	600VA max Characteristic data (B-C78 Fig.2)			
DC Input	D-6(1)	Rated voltage	DC48V (DC40 to 59V)	DC startup available		
	D-6(7)	Battery discharge cut-off voltage	34V±2V max (shutdown of battery circuit)			
	D-6(3)	Efficiency	69% typical	With rated input/output		
Output	—	Rated voltage	+3.3V +5V +12V -5V -12V +5VSB			
	—	Rated current	16A 28A 12A 0.5A 0.5A 1A			
	D-6(8)	Max current/power	20A 30A 13A 0.5A 0.5A 1A	Max output power is 350.3W.		
			193W max			
			337W max			
	D-6(10)	Minimum current	0A 3A 0A 0A 0A 0A			
	D-6	Total voltage accuracy (%)	±4 max ±4 max ±5 max ±5 max ±5 max ±5 max	Sum of temperature, input, and load regulations.		
	D-7(12)	Max ripple voltage (mVp-p)	50 max 50 max 100 max 50 max 100 max 50 max	Connect two wires to within 1mm from the output connector.		
D-7(12)	Max spike voltage (mVp-p)	100 max 100 max 200 max 100 max 200 max 100 max	Put a 0.1μF film capacitor and a 10μF electrolytic capacitor to measure. Characteristic data (B-C81 Fig.28)			
Protection	D-7(13)	Over Current Protection	OCP point (A)	22 min* 34 min* 14 min	Short circuit protection	
		Method	All outputs shut down		Foldback current limiting All outputs shut down	
	D-7(14)	Recovery (over current)	At AC operation	Reclosing input		Automatic recovery
		At DC operation	Reclosing input		Automatic recovery	
	D-7(14)	Over Voltage Protection	OVP point (V)	3.8 to 4.3 6.0 to 7.0 14 to 15.6	— — —	—
		Method	All outputs except for +5VSB shut down All outputs shut down at DC operation.		— — —	—
D-7(14)	Recovery (over voltage)	At AC operation	Reclosing input, or switching PS_ON# signal from 'H' to 'L'		— — —	
		At DC operation	Reclosing input		— — —	
—	Charge voltage	54V typical (At 25°C, no load)				
—	Charge current	0.5±0.2A (with 48V battery voltage)				
Environment	D-7(16)	Operating temperature/humidity	0-50°C/10-90%			There shall be no condensation.
	D-7(17)	Storage temperature/humidity	-25-70°C/10-95%			There shall be no condensation.
	D-7(18)	Vibration	Displacement amplitude of 0.15mm with a vibration frequency of 10-55Hz for 10 sweep cycles in the X-Y-Z directions for 45 minutes.			JIS-C-0040-1995
	D-7(19)	Mechanical shock	Acceleration of 150m/s ² for 11ms one time each in the X, Y, Z directions. No malfunction, damage, loosening, or coming-off.			JIS-C-0041-1995
Insulation	D-7(20)	Dielectric strength	AC 1500V for one minute between AC input and FG/DC output/DC input			At DC500V
	D-7(21)	Insulation resistance	50MΩ min between AC input and DC output/FG/DC input 50MΩ min between DC input-DC output—FG			
	D-7(22)	Leakage current	0.5mA max (AC100V)/1mA max (AC240V)			YEW. TYPE3226 (1kΩ) or equivalent
EMC	D-7(23)	Line noise immunity	±2000V (pulse width: 100ns and 800ns, repetitive cycle: 10-50ms)			It shall follow the DC output specification. There shall be no malfunction.
	D-7(24)	Electrostatic discharge	EN61000-4-2 compliant			
	D-7(25)	Radiated, radio-frequency EM field	EN61000-4-3 compliant			
	D-7(26)	Fast transient burst	EN61000-4-4 compliant			
	D-7(27)	Lightning surge	EN61000-4-5 compliant			
	D-7(28)	Conducted disturbances induced by radio-frequency	EN61000-4-6 compliant			
	D-7(29)	Power source frequency magnetic field	EN61000-4-8 compliant			
	D-8(30)	Voltage dip/regulation	EN61000-4-11 compliant Characteristic data (B-C80 Fig.21-22)			
	D-8(31)	Conducted emission	VCCI-A, FCC-A, and EN55022-A compliant			Measured with the unit embedded to our EMC measuring PC.
	D-8(32)	Harmonic current regulation	IEC1000-3-2 Class A and EN61000-3-2 Class A compliant Characteristic data (B-C78 Fig.5-6)			With rated input/output
Other	D-8(1-6)	Safety standard	UL60950 and CSA C22.2 No.60950 (c-UL)			
	D-8(34)	Cooling system	Forced-air cooling			
	D-8(35)	Output GND terminal	Capacitor grounding			
	D-8(38)	Output hold-up time	PWR_OK holds up 30ms min after AC failure Characteristic data (B-C80 Fig.19)			With rated output
	F-3	Reliability Grade	FA (Industrial equipment grade, double-sided PWB with through holes)			It is to follow our standard.
	D-8(41)	MTBF	76,000 H min			Based on EIAJ RCR-9102
	—	Weight	3.2 kg typical			
F-3	Warranty	Three years after delivery. If any faults belong to us, the defective unit shall be repaired or replaced at our cost.			Except for errors caused by operation not listed.	

Computer Power Supply - BRAIN

Control & Mechanism System Power Supply - LIMBS

- A. UPDATE
- B. SELECTION GUIDE
- B-A. PRODUCT PAGE GUIDELINE
- B-B. NONSTOP POWER SUPPLY
- B-C. AC+DC DUAL-INPUT PSU
- B-D. GENERAL PURPOSE PC PSU
- B-E. GENERAL PURPOSE REDUNDANT PSU
- B-F. OPTIONS
- C. SELECTION GUIDE
- C-A. PRODUCT PAGE GUIDELINE
- C-B. AC-DC SINGLE OUTPUT NONSTOP PSU
- C-C. AC-DC MULTI-OUTPUT NONSTOP PSU
- C-D. AC-DC SINGLE OUTPUT POWER SUPPLY
- C-E. AC-DC MULTI-OUTPUT POWER SUPPLY
- C-F. DC-DC CONVERTER
- C-G. OPTIONS
- D. TECHNICAL DICTIONARY
- E. COMPANY PROFILE
- F. BUSINESS MANUAL
- G. INDEX

Signal Input/Output Specification (Items are provided at normal temperature and humidity unless otherwise specified.)

Items	Specification	Note	
Input Signal	Output ON/OFF control signal (PS_ON#)	With 'H' or 'OPEN' input, +3.3V, +5V, +12V, -5V, and -12V outputs shut down. At backup operation (DC), battery connection (DC) shuts down with 'H' or 'OPEN' input.	Signal input between P1 connector 14-pin and COM pin
	Battery shutdown signal for TTL (SHUT_DOWN_T)	Battery connection is shut down with 'L' input. This function is only available during backup (DC) operation.	Signal input between P15 connector 2-pin and COM pin
	Battery shutdown signal for RS232C (SHUT_DOWN_R)	'Battery connection is shut down with 'positive' input. This function is only available during backup (DC) operation.	Front panel RS232C connector 4-pin
	Operation shifting control (BATT_CHECK)	At 'L' input, AC inverter is forcibly shut down, and it will be switched to battery (DC) operation to make pseudo blackout.	Signal input between P15 connector 5-pin and COM pin
Output Signal	Normal output signal (PWR_OK)	When +5V output is normal, 'H' is delivered (detection delay time: 200 to 350ms).	P1 connector 8-pin
	Blackout detection signal for TTL (AC_FAIL_T)	The signal goes 'OPEN' at low AC input voltage and blackout detection (open collector output) (detection delay time: 200 to 350ms).	P15 connector 3-pin
	Blackout detection signal for RS232C (AC_FAIL_R)	'Negative (-11V typical)' is delivered at low AC input voltage and blackout detection (detection voltage: AC80V typical, detection delay time: 20 to 40ms after AC failure)	Front panel RS232C connector 8-pin
	Low battery voltage signal for TTL (BATT_LOW_T)	'OPEN' is delivered when the battery terminal voltage decreases to 40±1V (open collector output). 'L' is delivered if the battery package is not connected.	P15 connector 4-pin
	Low battery voltage signal for RS232C (BATT_LOW_R)	'Negative (-11V typical)' is delivered when the battery terminal voltage decreases to 19.3±0.5V. 'Positive (+11V typical)' is delivered if the battery package is not connected.	Front panel RS232C connector 1-pin
	Fan alarm signal (FAN_ALARM)	When the fan lock status remains, square waves are delivered as shown below.	P15 connector 6-pin

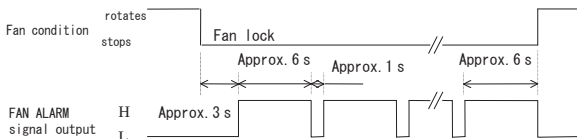

Signal Circuit

Input Signal Circuit	(PS_ON#), (SHUT_DOWN_T), (BATT_CHECK)	(SHUT_DOWN_R)	
Output Signal Circuit	(PWR_OK)	(AC_FAIL_T), (FAN_ALARM), (BATT_LOW_T)	(AC_FAIL_R), (BATT_LOW_R)

Interior View

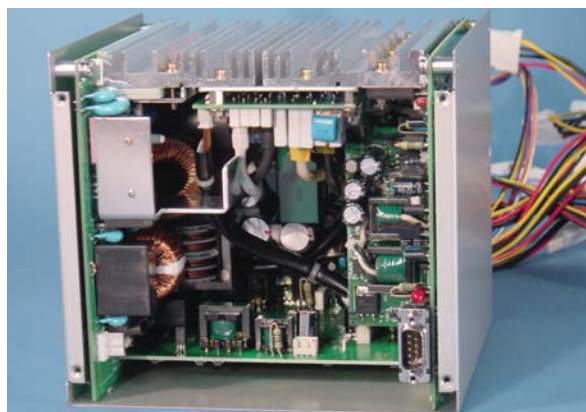

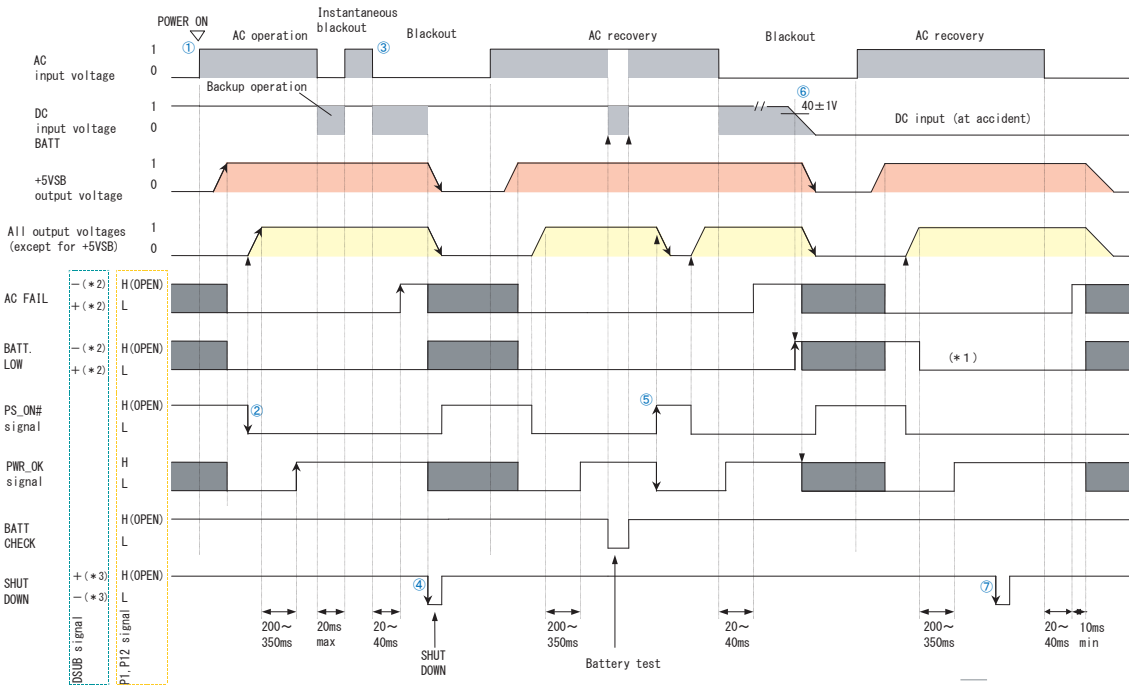

- (*1) Due to charger output, BATT.LOW is not delivered.
- (*2) Negative signal output shall be -11V typical. Positive signal output shall be +11V typical.
- (*3) Negative signal input shall be +0.4V to -30V. Positive signal input shall be +2.8V to +30V.

- ① With AC input, only +5VSB starts up.
- ② With PS_ON# 'L' input, all outputs start up. After 200 to 350ms, PWR_OK 'H' is delivered.
- ③ AC FAIL⁻negative (RS232C) or 'H' (OPEN)(TTL) is delivered 20 to 40ms after blackout.
- ④ At blackout, all outputs including 5VSB shut down with SHUT DOWN⁺positive (RS232C) or 'L'(TTL) input.
- ⑤ When AC input and all outputs including 5VSB start up, all outputs except for 5VSB shut down with PS_ON# 'H' (OPEN) input.
- ⑥ When the battery voltage decreases to 40±1V or less at backup operation, BATT LOW⁻negative (RS232C) or 'H' (OPEN)(TTL) is delivered; after it decreases to 34±2V or less, all outputs, including 5VSB shut down.
- ⑦ At AC input, the output does not change with SHUT DOWN⁺positive (RS232C) or 'L' (TTL) input.

Block Diagram

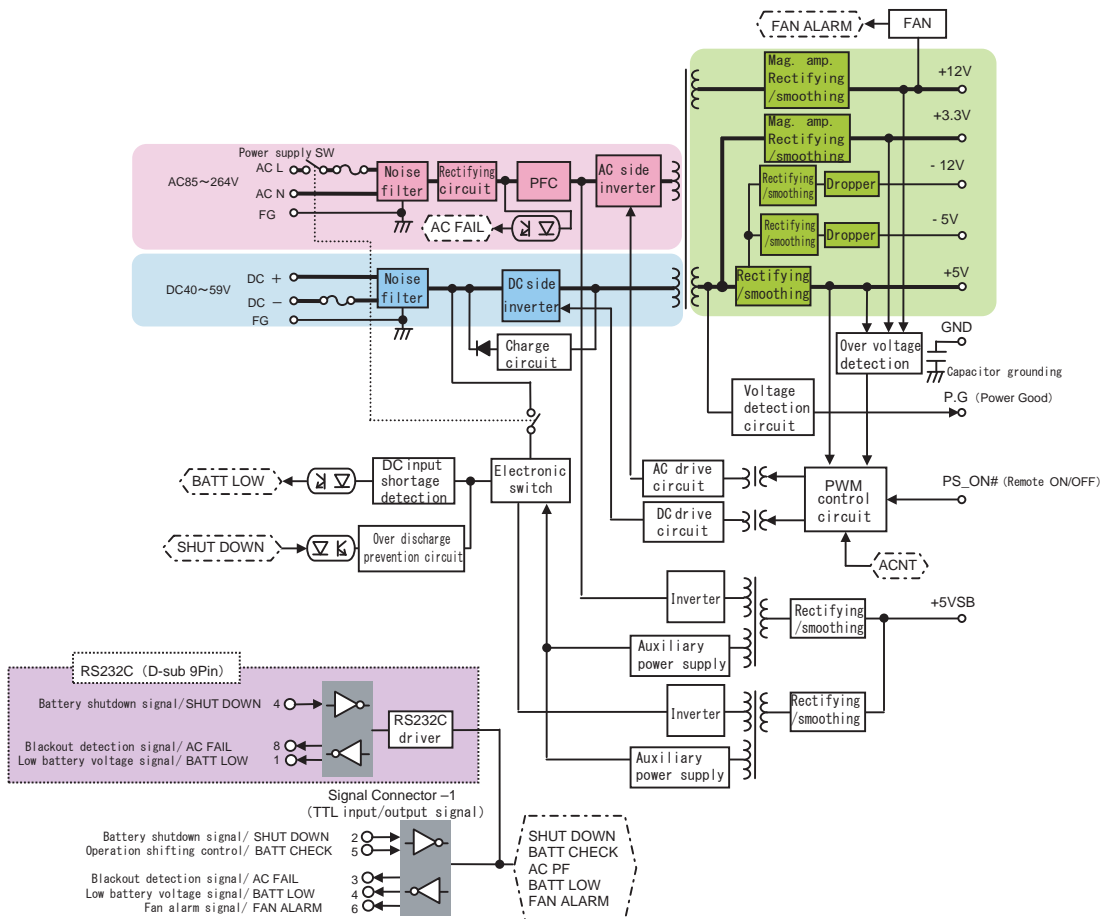

A. UPDATE

Computer Power Supply - BRAIN

B. SELECTION GUIDE

B. PRODUCT PAGE GUIDELINE

B. NONSTOP POWER SUPPLY

B. AC+DC DUAL-INPUT PSU

B. GENERAL PURPOSE PC PSU

B. GENERAL PURPOSE REDUNDANT PSU

B. OPTIONS

Control & Mechanism System Power Supply - LIMBS

C. SELECTION GUIDE

C. PRODUCT PAGE GUIDELINE

C. AC-DC SINGLE OUTPUT NONSTOP PSU

C. AC-DC MULTI-OUTPUT NONSTOP PSU

C. AC-DC SINGLE OUTPUT POWER SUPPLY

C. AC-DC MULTI-OUTPUT POWER SUPPLY

C. DC-DC CONVERTER

C. OPTIONS

D. TECHNICAL DICTIONARY

E. COMPANY PROFILE

F. BUSINESS MANUAL

G. INDEX

Outline Drawing

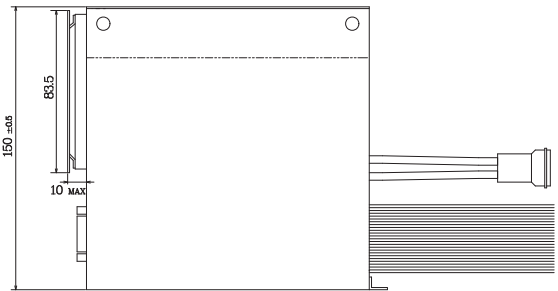
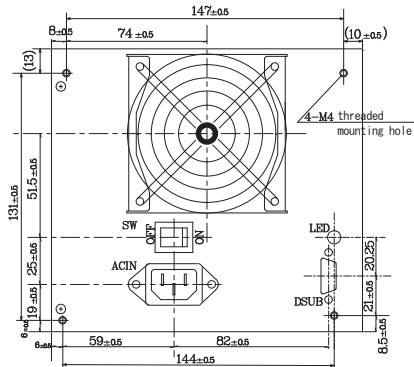
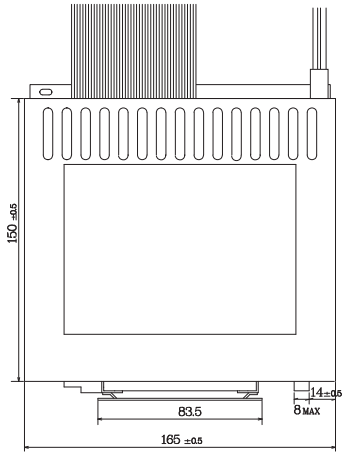

Note: The depth of mounting screws inside the power supply shall be 4mm max.

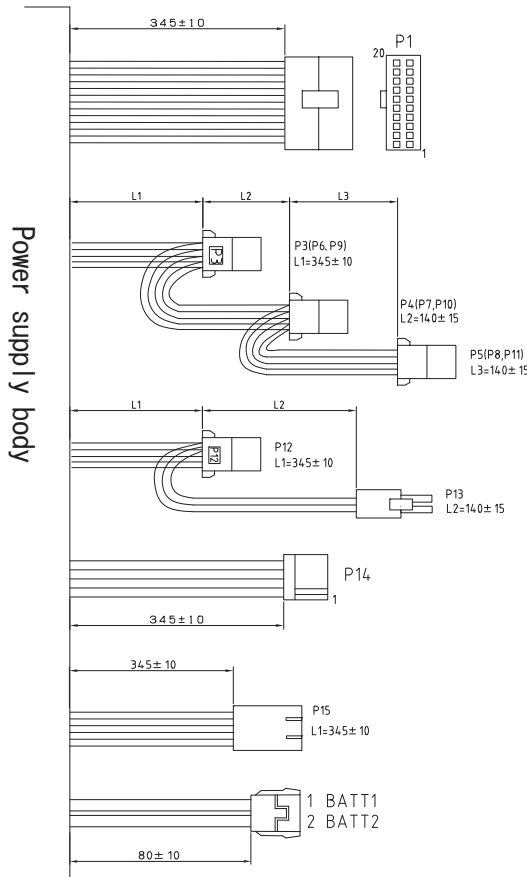

Output Harness





CN NAME	PIN NO	FUNCTION	WIRE		CONNECTOR TYPE
			COLOR	TYPE UL1007	
P1	1	+3.3VDC	BROWN	AWG#18	Housing 5557-20R (Molex) Terminal 5556 (Molex)
	2	+3.3VDC	BROWN		
	3	COM	BLACK		
	4	+5VDC	RED		
	5	COM	BLACK	AWG#22	
	6	+5VDC	RED		
	7	COM	BLACK		
	8	P.G	ORANGE		
	9	+5VS	YELLOW	AWG#18	
	10	+12VDC	YELLOW		
	11	+3.3VDC	BROWN	AWG#18	
	12	-12VDC	BLUE		
	13	COM	BLACK	AWG#22	
	14	ON/OFF	VIOLET		
	15	COM	BLACK	AWG#18	
	16	COM	BLACK		
	17	COM	BLACK		
	18	-5V	WHITE		
	19	+5VDC	RED	UL1007	
	20	+5VDC	RED		
P3 ~ P12	1	+12VDC	YELLOW	UL1007	Housing LCP-04(JST) Terminal SLC22T-2.0(JST)
	2	COM	BLACK		
	3	COM	BLACK		
	4	+5VDC	RED		
P14	1	+5VDC	RED	AWG#22	Housing 171822-4(AMP) Terminal 170204-1(AMP)
	2	COM	BLACK		
	3	COM	BLACK		
	4	+12VDC	YELLOW		
P13	1	COM	BLACK	UL1007	Housing ELP-02V(JST) Terminal SLF-42T-1.3E(JST)
	2	+12VDC	YELLOW		
P15	1	COM	BLACK	UL1007	Housing 51030-0630 (Molex) Terminal 50084-8114 (Molex)
	2	SHUTDOWN	YELLOW		
	3	AC FAIL	BLUE		
	4	BATT LOW	WHITE		
	5	BATT CHECK	ORANGE		
	6	FAN ALM	VIOLET		
BATT1	1	BATT +	RED	UL1007	Housing VLR-02V(JST) Terminal SVM-61T-P2.0(JST)
BATT2	2	BATT -	BLACK		
BATT2	1	BATT +	RED	AWG#14	
BATT2	2	BATT -	BLACK		

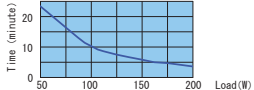

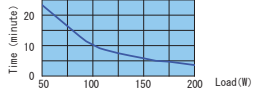
Note: The harness length shall be measured from the case of power supply's body.

Optional Products (Sold separately)

Battery package					
Page	Picture	Model	Battery type	Shape (size)	Backup time
B-G2		BS05A-P24/2. 2L	Lead	5-inch bay fixed type (W × D × H=146 × 190 × 37 mm)	
B-G4		RBS01A-P24/2. 2L	Lead	5-inch bay fixed, removable type (W × D × H=146 × 245 × 42 mm)	

※The backup time is a reference value at initial use; it is not a guaranteed value.
 ※NSP2-375-D4S needs two battery packages (serial connection).

Cable				
Page	Picture	Model	Type	Description
B-G46		WH2601-01	RS232C communication cable	Dedicated to Windows 95/98/NT.
B-G46		WH2753	AC power cord	AC125V 12A 【PSE】

Software				
Page	Picture	Model	Type	Description
B-G60		NSP Pro for 95/98	Automatic shutdown software	Dedicated to Windows 95/98. RS232C cables, WH2601-01 and WH2601-02 (accessories)
B-G60		NSP Pro for NT	Automatic shutdown software	Dedicated to Windows NT RS232C cable, WH2601-01 (accessory)

Other optional components					
Page	Model	Description	Page	Model	Description
B-G52	ACC2637	Automatic startup unit	B-G50	WH5105	12V 4-pin connector conversion harness(80mm)
B-G49	WH2820	20-pin extension harness (600mm)	B-G50	WH5105-02	12V 4-pin connector conversion harness(320mm)
B-G49	WH2747	20-pin extension harness (450mm)	B-G47	WH5055	AT connector conversion harness
B-G49	WH2892-02	20-pin extension harness (200mm)	B-G47	ACC5046	Harness with PS_ON switch
B-G51	WH2812	PCI-E 6-pin connector conversion harness	B-G48	ACC5077	PS_ON terminal short connector
			B-G48	WH5073	PS_ON short terminal 20-pin harness

48V Input (D4S) Battery

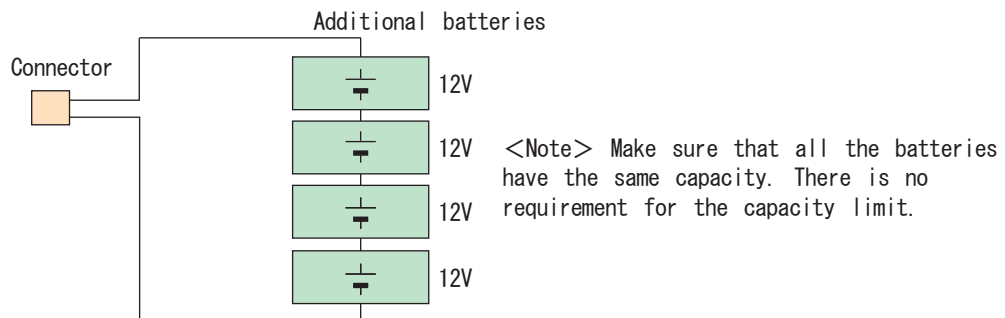
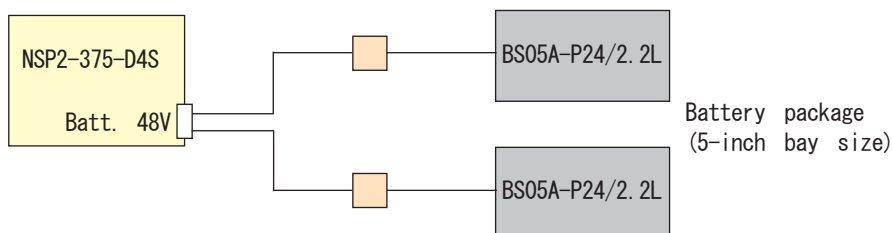

Computer Power Supply - BRAIN

Control & Mechanism System Power Supply - LIMBS

A. UPDATE

B.-A. SELECTION GUIDE

B.-B. PRODUCT PAGE GUIDELINE

B.-C. NONSTOP POWER SUPPLY

B.-D. AC+DC DUAL-INPUT PSU

B.-E. GENERAL PURPOSE PC PSU

B.-F. GENERAL PURPOSE REDUNDANT PSU

B.-G. OPTIONS

C.-A. SELECTION GUIDE

C.-B. PRODUCT PAGE GUIDELINE

C.-C. AC-DC SINGLE OUTPUT NONSTOP PSU

C.-D. AC-DC MULTI-OUTPUT NONSTOP PSU

C.-E. AC-DC SINGLE OUTPUT POWER SUPPLY

C.-F. AC-DC MULTI-OUTPUT POWER SUPPLY

C.-G. DC-DC CONVERTER

C.-H. OPTIONS

D. TECHNICAL DICTIONARY

E. COMPANY PROFILE

F. BUSINESS MANUAL

G. INDEX

Characteristics Data (Examples of actual measurement)

Computer Power Supply - BRAIN

Control & Mechanism System Power Supply - LIMBS

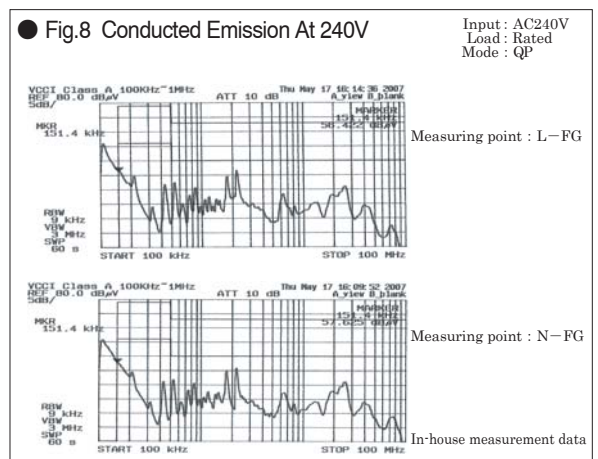
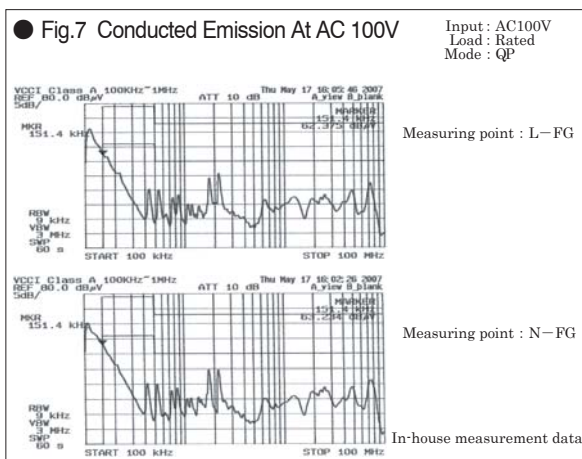
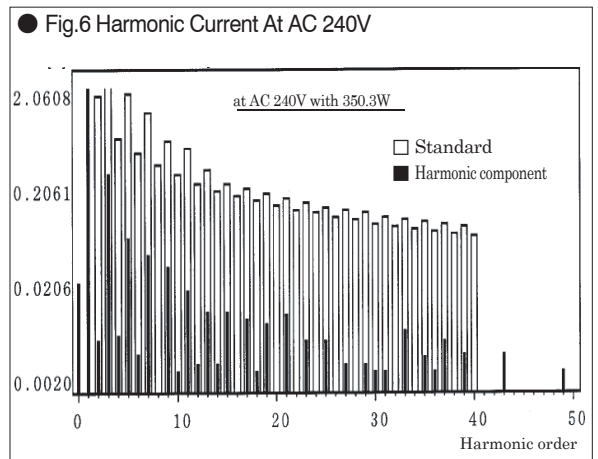
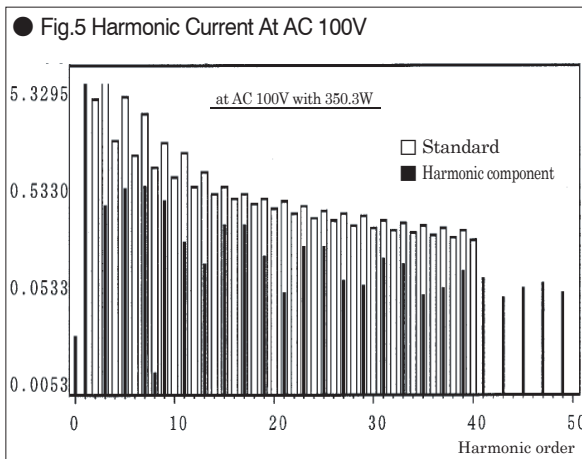
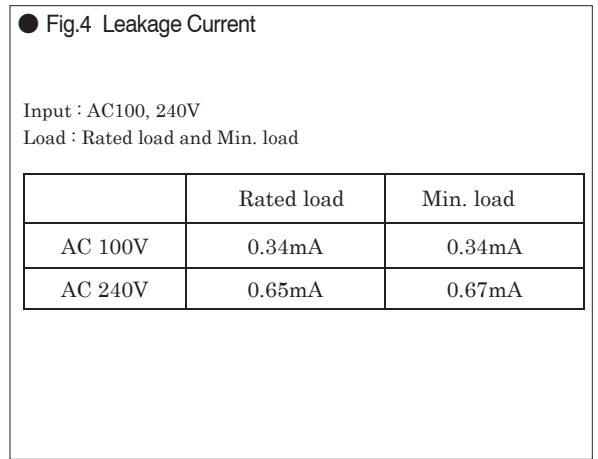
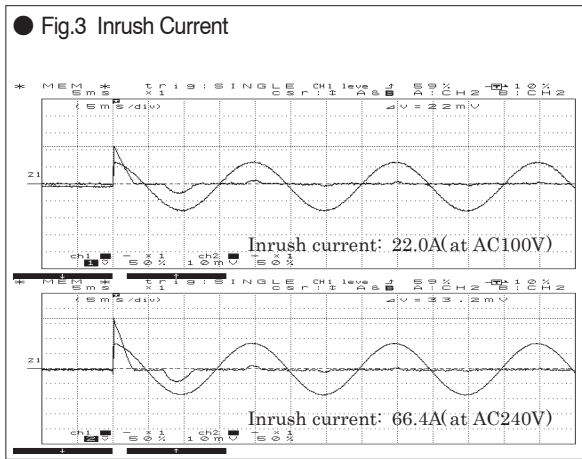
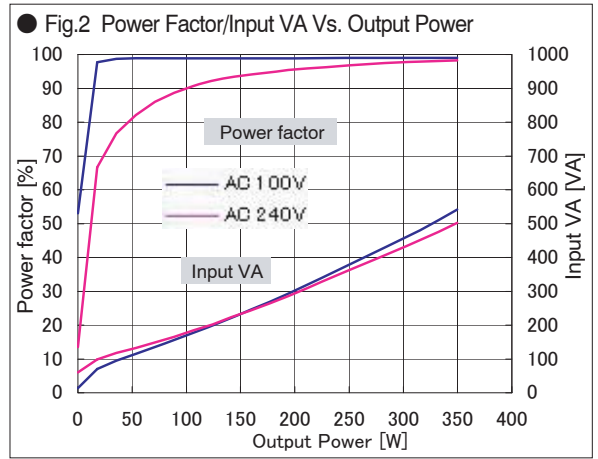
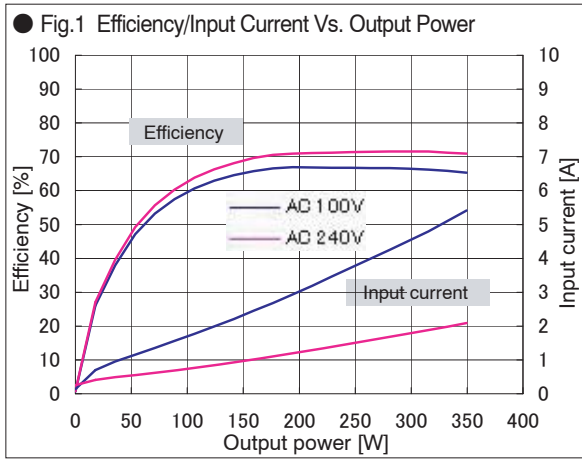

● Fig.9 AC Startup Voltage (Rated load)

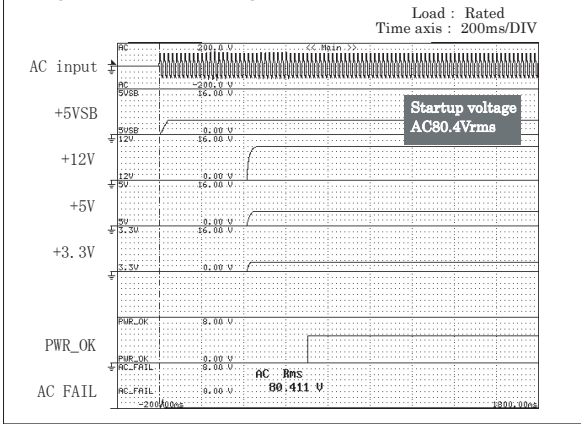

● Fig.10 AC Startup Voltage (Min. load)

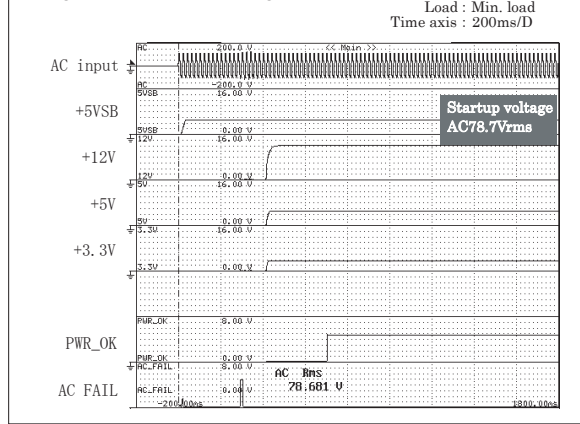

● Fig.11 Rising Sequence At AC 100V

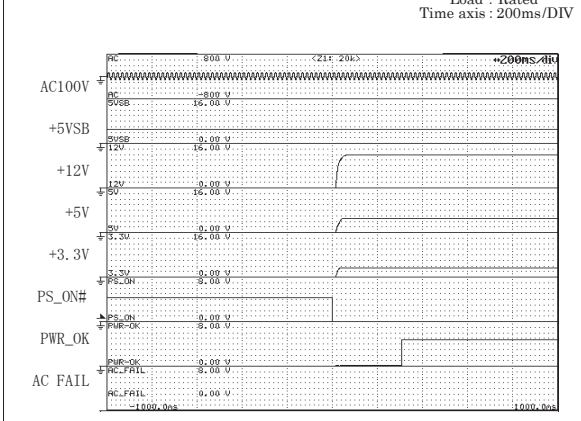

● Fig.12 Rising Characteristics At AC 100V

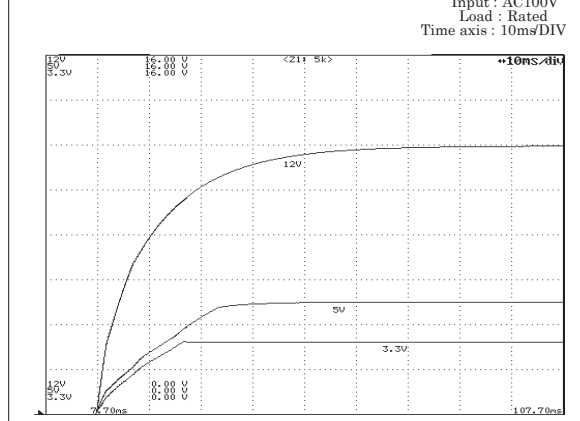

● Fig.13 Rising Sequence At AC 240V

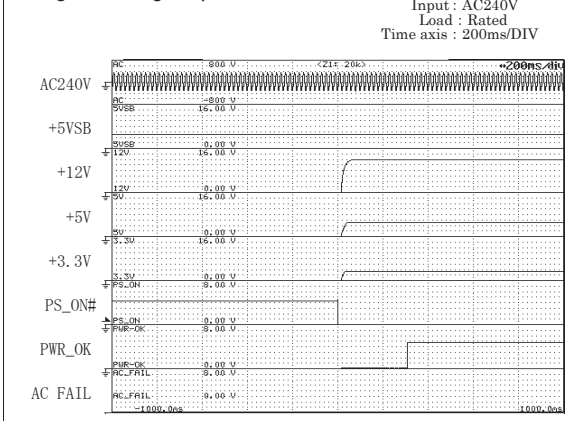

● Fig.14 Rising Characteristics At AC 240V

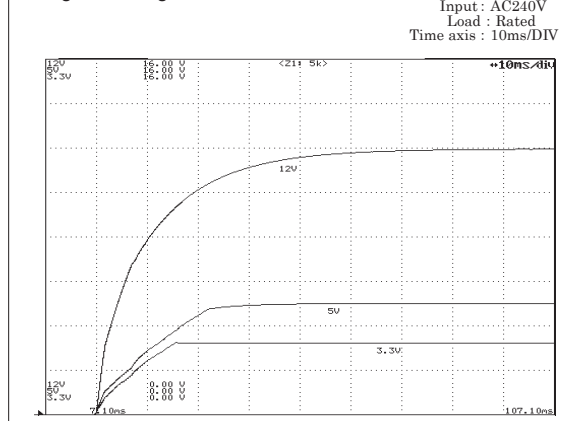

● Fig.15 Falling Characteristics At AC 100V When REMOTE Is Off

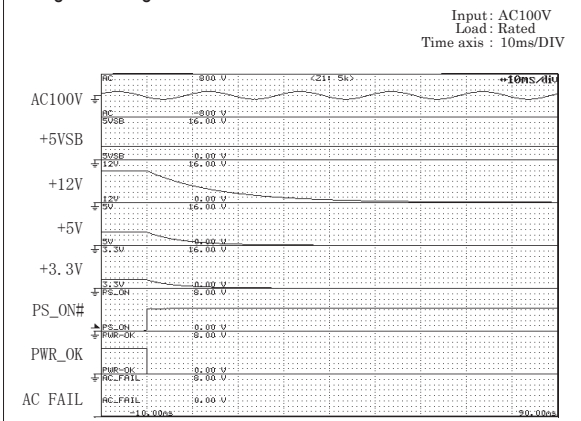

● Fig.16 Falling Characteristics At AC 240V When REMOTE Is Off

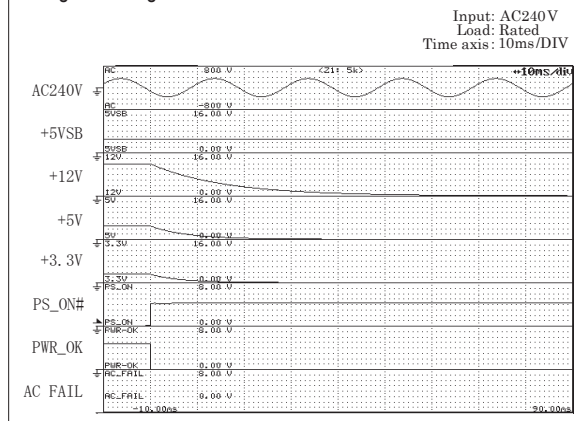

IV

Computer Power Supply - BRAIN

Control & Mechanism System Power Supply - LIMBS

SELECTION GUIDE
B.-A

PRODUCT PAGE GUIDELINE
B.-B

NONSTOP POWER SUPPLY
B.-C

AC+DC DUAL-INPUT PSU
B.-D

GENERAL PURPOSE PC PSU
B.-E

GENERAL PURPOSE REDUNDANT PSU
B.-F

OPTIONS
B.-G

SELECTION GUIDE
C.-A

PRODUCT PAGE GUIDELINE
C.-B

AC-DC SINGLE OUTPUT NONSTOP PSU
C.-C

AC-DC MULTI-OUTPUT NONSTOP PSU
C.-D

AC-DC SINGLE OUTPUT POWER SUPPLY
C.-E

AC-DC MULTI-OUTPUT POWER SUPPLY
C.-F

DC-DC CONVERTER
C.-G

OPTIONS
C.-H

TECHNICAL DICTIONARY
D.

COMPANY PROFILE
E.

BUSINESS MANUAL
F.

INDEX
G.

Characteristic Data (Examples of actual measurement)

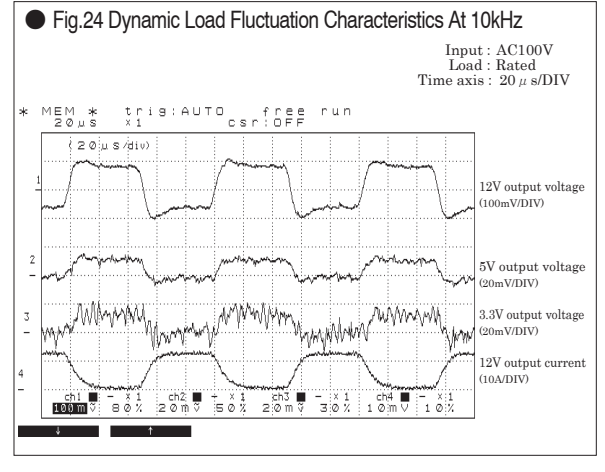
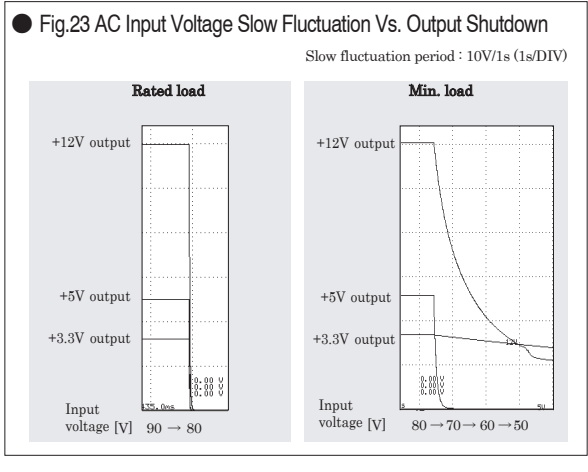
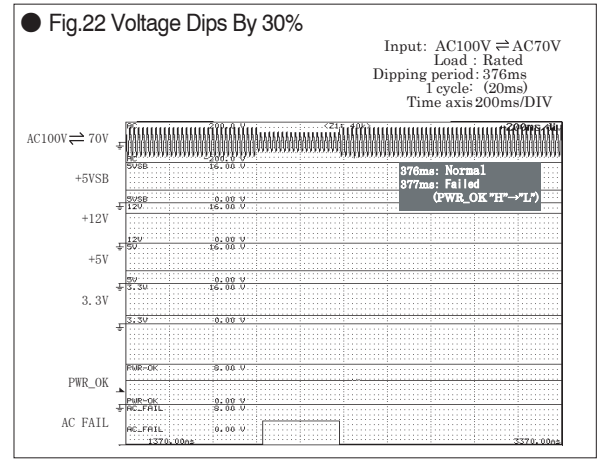
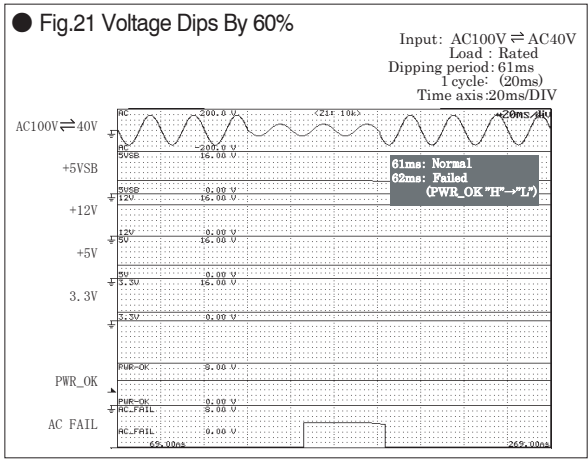
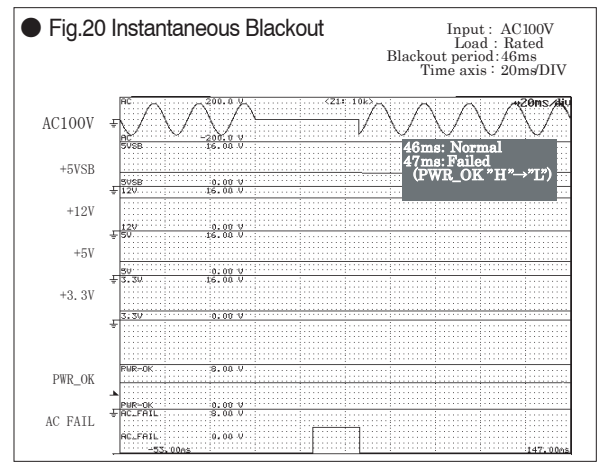
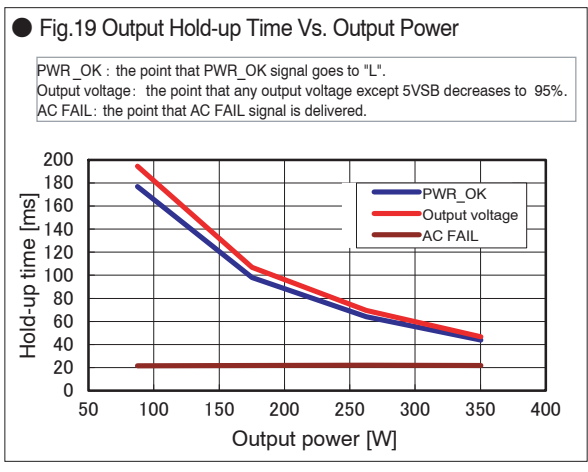
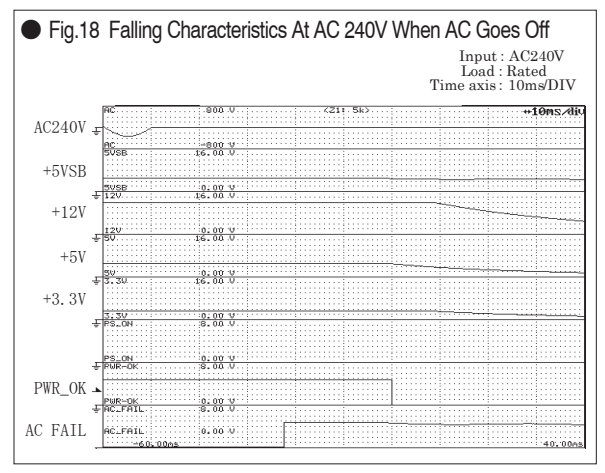
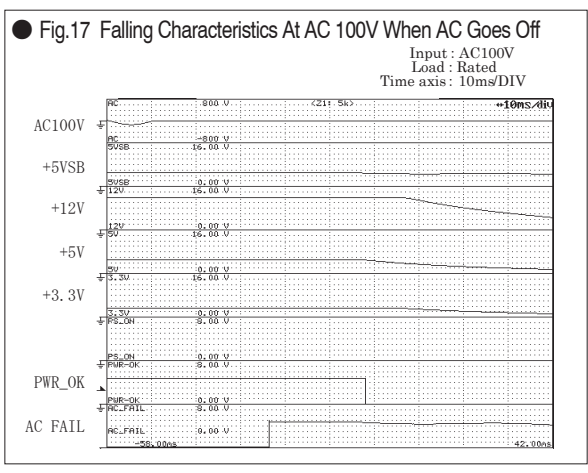

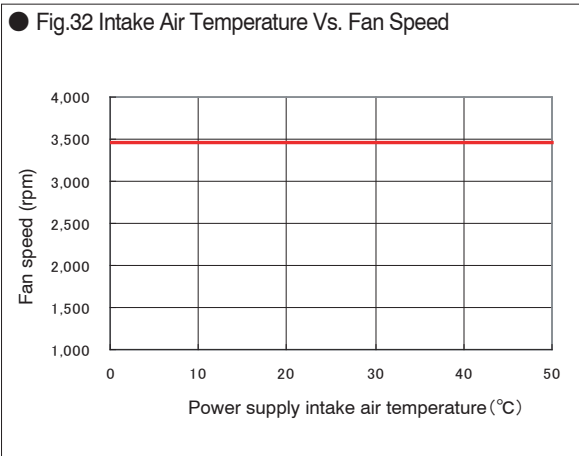
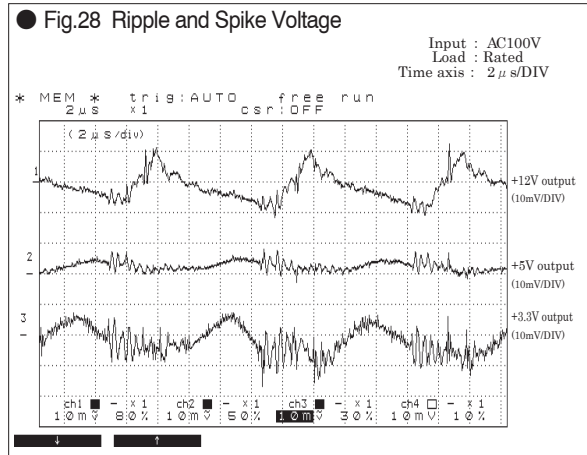
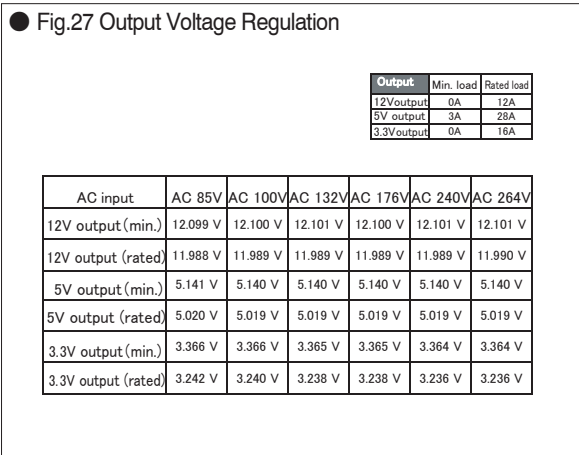
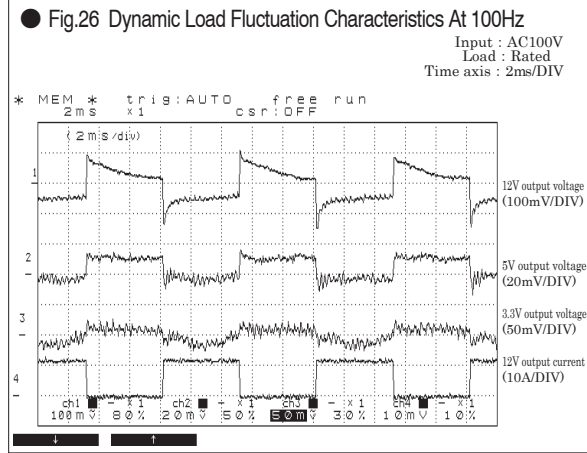
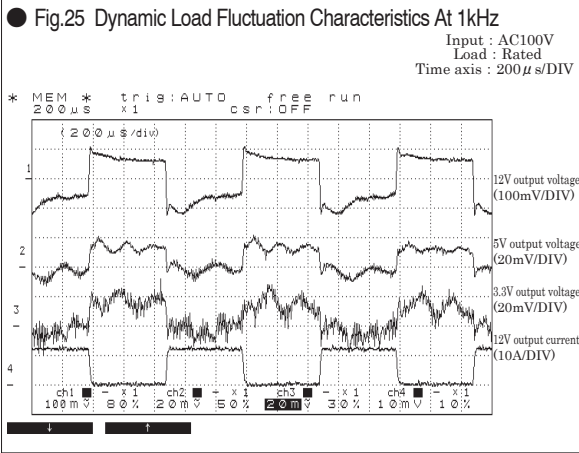

Column 26

Baby AT

Baby AT is a type of standardized motherboard for PC/AT compatible PCs. Baby AT has succeeded the specification of IBM's PC/XT motherboard. Its width is smaller than that of AT specification. Recently, ATX has become more prevalent, and Baby AT specification is no longer used as often.

The size is bigger than ATX, and its dimensions are: W × H × D (mm) = 165 × 150 × 150
 Nipron's power supplies meet its outline specification only.

Computer Power Supply - BRAIN

- A. UPDATE
- B. SELECTION GUIDE
 - B-A. PRODUCT PAGE GUIDELINE
 - B-B. NONSTOP POWER SUPPLY
 - B-C. AC+DC DUAL-INPUT PSU
 - B-D. GENERAL PURPOSE PC PSU
 - B-E. GENERAL PURPOSE REDUNDANT PSU
 - B-F. OPTIONS
- B. SELECTION GUIDE
 - C-A. PRODUCT PAGE GUIDELINE
 - C-B. AC-DC SINGLE OUTPUT NONSTOP PSU
 - C-C. AC-DC MULTI-OUTPUT NONSTOP PSU
 - C-D. AC-DC SINGLE OUTPUT POWER SUPPLY
 - C-E. AC-DC MULTI-OUTPUT POWER SUPPLY
 - C-F. DC-DC CONVERTER
 - C-G. OPTIONS

Control & Mechanism System Power Supply - LIMBS

- D. TECHNICAL DICTIONARY
- E. COMPANY PROFILE
- F. BUSINESS MANUAL
- G. INDEX