

# Desktop PC power supply PCSM-100-X2S

## Compact & Silent PC power supply



PCSM-100-X2S

Model	Description	Stock	Standard Price (Before Tax)
PCSM-100-X2S		Standard stock	¥13,500

**Model name coding**  
**PCSM - 100 - X 2 S**  
 ① ② ③ ④ ⑤

① Series name      ④ +3.3V output equipped  
 ② Output power    ⑤ Standard  
 ③ ATX output

### Features

- Bestselling product with the track record in the market
- Low cost
- Silent with TSFC Fan
- Production to be continued until 2008.
- For customers who need higher power, PCSF-200P-X2S is recommended.

Refer to B-B1 "Product page guideline" for icons.

Safety standard	<b>UL</b>	<b>CSA</b>	<b>EN</b>	<b>CE</b>	<b>CCC</b>
Reliability grade	<b>HFA</b>	<b>FA</b>	<b>HOA</b>	<b>OA</b>	

### Function

DC start     RS 232C     USB     TTL     PFC     Silence     5VSB FAN     TSFC FAN     Connection     Fit for Panel     RoHS Directive

※ RoHS Directive will be available in March, 2008.

### Input

AC input	90V to 264V (Worldwide range)
----------	-------------------------------

### Output

Output voltage	+3.3V	+5V	+12V	-12V	+5VSB
Max. current/	6A	10A	1.5A	0.2A	0.72A
Max. power (continuous)	Total 93.8W				
Peak current/Peak power (within 5 seconds)	6A	12A	4.8A	0.2A	1.2A
	Total 145.8W				
Min. load	0A	1A	0A	0A	0A

### Dimension

W × H × D (mm)	100 × 63.5 × 125 (APPENDIX D size)
----------------	------------------------------------

### Output connectors

20 Pin     24 Pin     AT     12V     AUX     Processor     ×3     ×1     S-ATA     PCI-E

Page	Items	Specification	Measurements, etc.		
Input voltage	D-6(1) Rated voltage	AC100-240V (AC90-264V) <a href="#">Data on B-E133 Fig.9-10</a>	Worldwide range Voltage range for harmonic regulation shall be up to 253V.		
	D-6(2) Frequency	50/60Hz	47-63Hz		
	D-6(3) Efficiency	64% min. (67% typical) <a href="#">Data on B-E132 Fig.1</a>	at Max. output power		
	D-6(4) Power factor	<a href="#">Data on B-E132 Fig.2</a>			
	D-6(5) Inrush current	50A peak at AC 240V <a href="#">Data on B-E132 Fig.3</a>	at Rated Output and Cold start at 25°C		
	D-6(6) Input VA	150VA typical at AC 100V <a href="#">Data on B-E132 Fig.2</a> 10VA typical at AC 100V, 20VA typical at AC 240V	at rated output PS_ON signal: 'H' or 'OPEN', 5VSB at rated load		
Output	— Rated voltage	+3.3V +5V +12V -12V +5VSB			
	— Rated current	6A 10A 1.5A 0.2A 0.72A	Total rated output power: 350W		
	D-6(8) Max. Current/Power	6A 10A 1.5A 0.2A 0.72A	Max. output power: 93.8W		
	D-6(9) Peak Current/Power	6A 12A 4.8A 0.2A 1.2A	93.8W max.	Peak output power: 145.8W (within 15 seconds)	
		145.8W max.			
	D-6(10) Min. load	0A 1A 0A 0A 0A			
	D-6(11) Total Voltage Accuracy (%)	±5 max. ±5 max. ±5 max. ±6 max. ±5 max.		Total output voltage accuracy including temperature and elapsing time drift when input voltage changes from min. to max. and load for all outputs are changed statically and arbitrarily from 40 to 60%.	
	D-7(12) Max. Ripple Voltage (mVp-p)	50 max. 50 max. 120 max. 120 max. 50 max.		To be measured on a test board with an electrolytic capacitor connected. (The test board shall be away from load lines and within 150mm from output terminals). <a href="#">Data on B-E135 Fig.28</a>	
	D-7(12) Max. Spike Voltage (mVp-p)	100 max. 100 max. 170 max. 170 max. 100 max.			
	Protection	D-7(13) Overcurrent Protection	OCP point (A)	6.3 min. — — — —	All other outputs are rated load. All other outputs are peak load.
Method			All outputs other than +5VSB shutdown	Foldback current limiting Intermittent operation	
D-7(14) Recovery		Recovery	Reclosing of AC input (Reclosing interval shall be 60 sec or longer)	Automatic recovery	All outputs shut down when +5VSB is shorted. (Automatic recovery)
		OVP point (V)	3.7~4.3 5.6~7.0 — —		
Environment	D-7(16) Operating Temp. and Humidity	10-50°C/20-90%	No condensation		
	D-7(17) Storage Temp. and Humidity	-20-70°C/10-95%	No condensation		
	D-7(18) Vibration	To endure for 30 minutes in each of X, Y, and Z direction under the following conditions of full amplitude: 0.15mm, vibration frequency: 10 to 55Hz, and sweep cycle: 3 minutes.	at no operation		
	D-7(19) Mechanical strength	There shall be no malfunction, damage, loosening, nor coming-off after the test of 98m/s <sup>2</sup> of acceleration for 20 ms in each of X, Y, and Z direction.	at no operation		
Insulation	D-7(20) Dielectric Strength	AC 1500V for 1 minute between AC input and DC-output/FG	Cut-off current: 20mA max. at normal temp. and humidity		
	D-7(21) Insulation Resistance	50MΩ min. between AC input and DC-output/FG	At DC500V at normal temp. and humidity		
	D-7(22) Leakage Current	0.5mA max. at AC 100V/1mA max. at AC 200V <a href="#">Data on B-E132 Fig.4</a>	YEW. TYPE3226 (1kΩ) or equivalent at normal temp. and humidity		
EMC	D-7(23) Line Noise Immunity	1200V min. (Pulse width: 50 to 1000ns, Cycle period: 30 to 100Hz)	To be measured by INS-410 There shall be no DC-component fluctuation and no malfunction.		
	D-7(24) Electrostatic Discharge	EN61000-4-2 compliant			
	D-7(25) Radiated, radio-frequency, electromagnetic field immunity	EN61000-4-3 compliant			
	D-7(26) Fast Transient Burst	EN61000-4-4 compliant			
	D-7(27) Lightning Surge	EN61000-4-5 compliant			
	D-7(28) Conductive Radio-Frequency Electromagnetic Field	EN61000-4-6 compliant			
	D-7(29) Power Frequency Magnetic Field Immunity	EN61000-4-8 compliant			
	D-8(30) Voltage Dips and Fluctuation	EN61000-4-11 compliant <a href="#">Data on B-E134 Fig.21-22</a>			
	D-8(31) Conducted Emission	VCCI-A compliant	To be measured at single power supply		
	D-8(32) Harmonic Current Regulation	IEC1000-3-2 compliant <a href="#">Data on B-E132 Fig.5-6</a>	Input voltage range: 90 to 253V		
Others	D-8(1-6) Safety Standard	UL1950, CSA No. 950 (c-UL), and EN60950			
	D-8(34) Cooling System	Forced air cooling (TSFC motor equipped)			
	D-8(35) Output GND Grounding	Connected to chassis (FG)			
	D-8(38) Output Hold-up Time	<a href="#">Data on B-E134 Fig.19</a>	at rated load		
	F-3 Reliability Grade	HOA	To follow our standard		
	F-3 Weight	1.2 kg typical			
F-3 Warranty	One year after delivery. However, if any faults belong to us, the defective unit shall be repaired or replaced at our cost.	Except when wrong operation is conducted out of product specification, etc.			

Computer Power Supply - BRAIN

Control & Mechanism System Power Supply - LIMBS

**Column 9**

Reliability grade HOA means;  
 This is Nipron's unique grade criteria. Each grade is classified according to the circumstances under which power supplies are used.  
 The purpose of the grade is to prevent power supplies from operation under wrong circumstances regarding power supply design criteria. Definition of HOA grade specifies "the power supply as high grade office use power supply. Major application is office installations in buildings, and in basic facilities where the circumstances are relatively controlled."  
 For more details, refer to page F-3 in "BUSINESS MANUAL."

- B. SELECTION GUIDE
- B. PRODUCT PAGE GUIDELINE
- B. NONSTOP POWER SUPPLY
- B. AC+DC DUAL-INPUT PSU
- B. GENERAL PURPOSE PC PSU
- B. GENERAL PURPOSE REDUNDANT PSU
- B. OPTIONS
- C. SELECTION GUIDE
- C. PRODUCT PAGE GUIDELINE
- C. AC-DC SINGLE OUTPUT NONSTOP PSU
- C. AC-DC MULTI-OUTPUT NONSTOP PSU
- C. AC-DC SINGLE OUTPUT POWER SUPPLY
- C. AC-DC MULTI-OUTPUT POWER SUPPLY
- C. DC-DC CONVERTER
- C. OPTIONS
- D. TECHNICAL DICTIONARY
- E. COMPANY PROFILE
- F. BUSINESS MANUAL
- G. INDEX

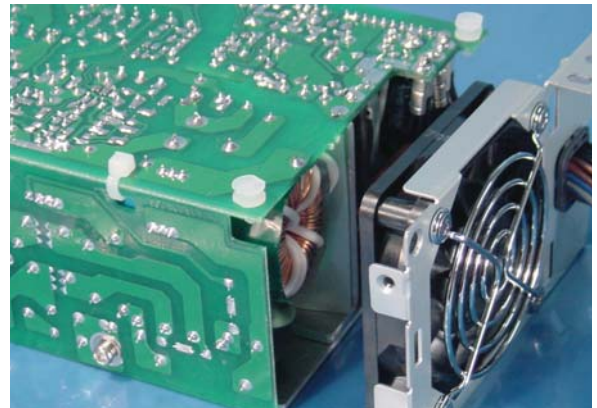
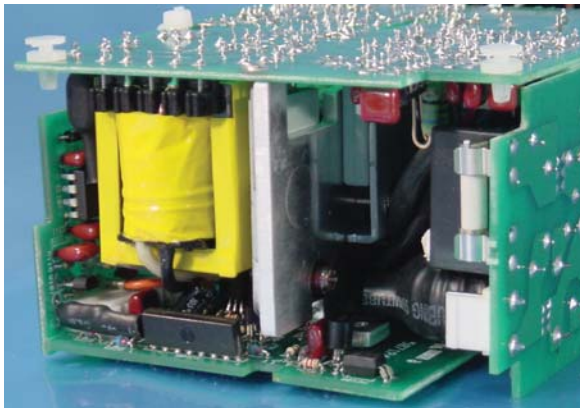
## Signal Input/Output Specification (Items are provided at normal temperature and humidity unless otherwise specified.)

Items	Specification	Note
Input signal	Output ON/OFF control signal (PS_ON#)	Upon receipt of 'L', +3.3V, +5V, +12V, and -12V are output. When 'H' or 'OPEN' is received, +3.3V, +5V, +12V, and -12V shut down. Also, latch lock circuit is reset when outputs are shut down due to OCP operation.
	+3.3V SENSE	The terminal to detect +3.3V voltage. By connecting to the load end, the voltage drop of +side output cable only is compensated.
	FAN C	Fan operates at the highest speed when the input signal level is 10.5V±0.5% or higher, and when the signal level is lower than that, or the input is open, the fan speed control inside the power supply has the priority.
Output signal	Normal output signal (PWR_OK)	'H' signal is delivered when output is normal. (Detection delay time: 100 to 500ms)

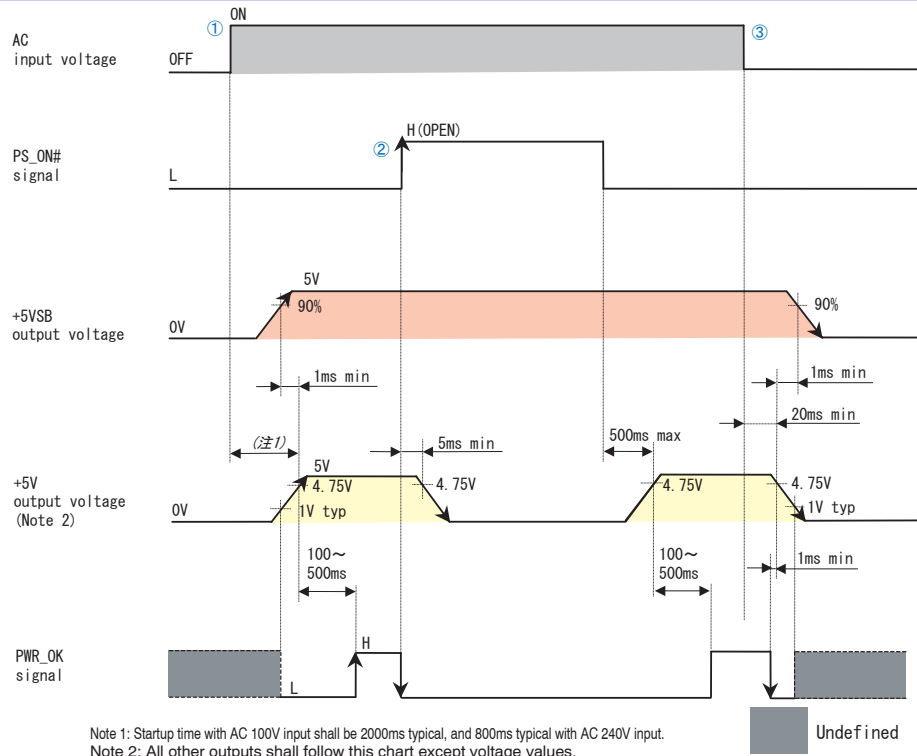
  

Signal Circuit		
Input signal circuit		Output signal circuit
<p>(PS_ON#)</p>	<p>(FAN C)</p>	<p>(PWR_OK)</p>

## Interior View

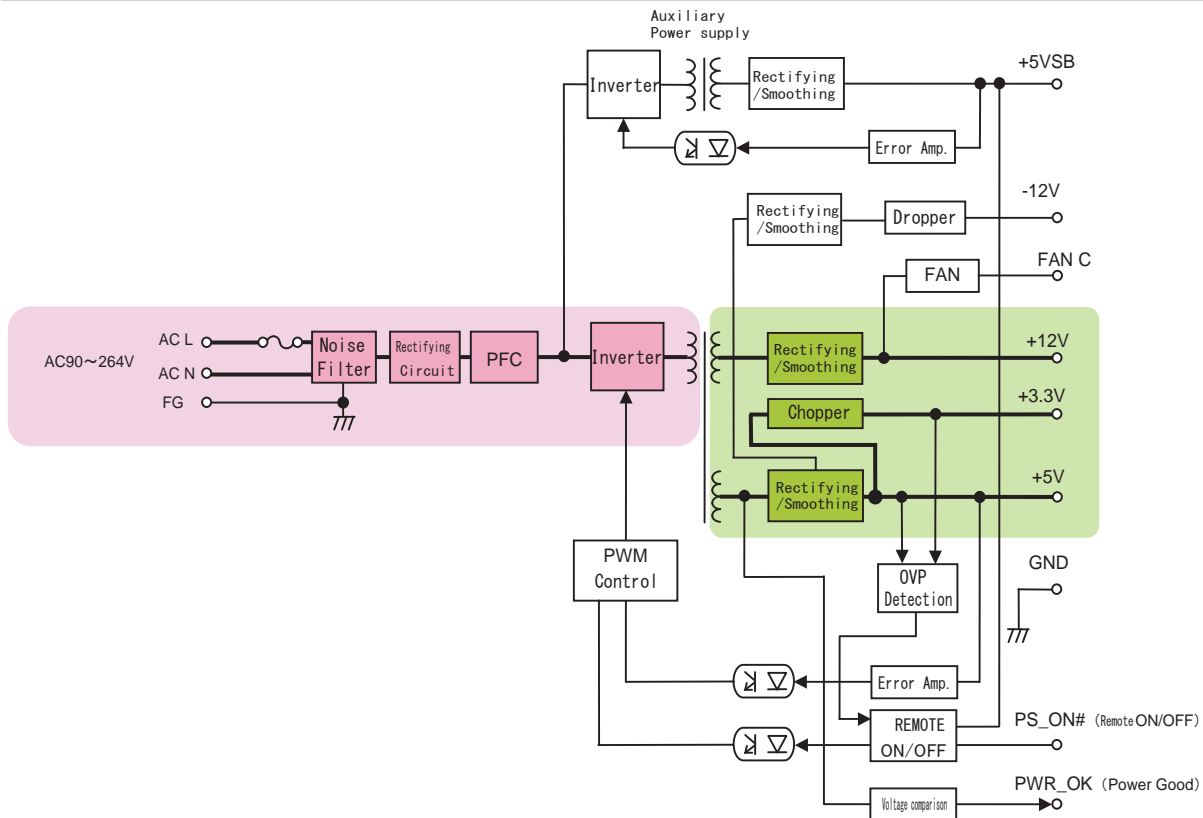


# Sequence Timing Chart



- ① All outputs start up with PS\_ON#"L" when AC input is turned on. PWR\_OK goes to "H" 100 to 500ms after +5V output has started up.
- ② All outputs except +5VSB shut down upon receipt of PS\_ON#"H".
- ③ At blackout, all outputs except +5VSB shut down 20ms or later than the blackout, and PWR\_OK "L" is delivered 1ms or earlier than that

# Block Diagram



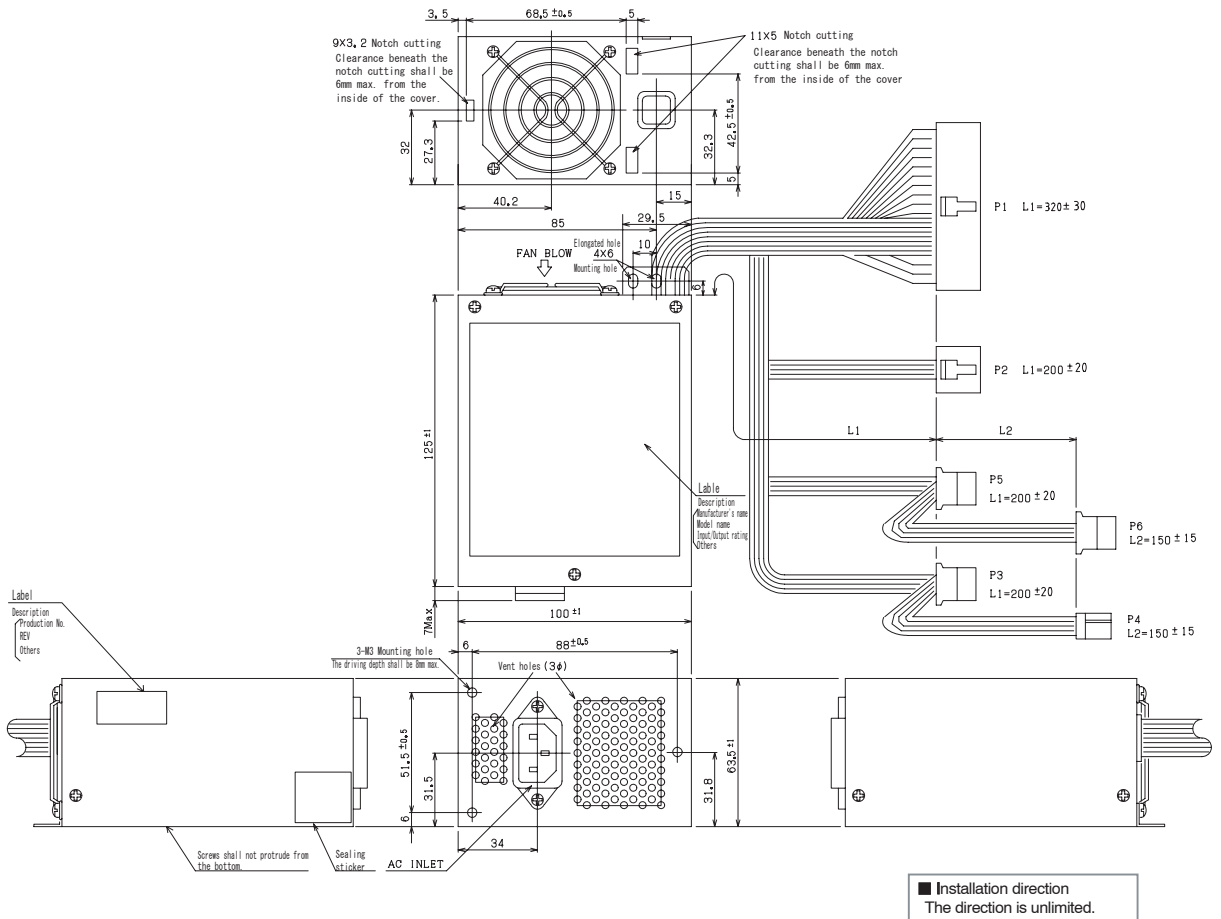
Computer Power Supply - BRAIN

Control & Mechanism System Power Supply - LIMBS

- A. UPDATE
- B.-A. SELECTION GUIDE
- B.-B. PRODUCT PAGE GUIDELINE
- B.-C. NONSTOP POWER SUPPLY
- B.-D. AC+DC DUAL-INPUT PSU
- B.-E. GENERAL PURPOSE PC PSU
- B.-F. GENERAL PURPOSE REDUNDANT PSU
- B.-G. OPTIONS
- C.-A. SELECTION GUIDE
- C.-B. PRODUCT PAGE GUIDELINE
- C.-C. AC-DC SINGLE OUTPUT NONSTOP PSU
- C.-D. AC-DC MULTI-OUTPUT NONSTOP PSU
- C.-E. AC-DC SINGLE OUTPUT POWER SUPPLY
- C.-F. AC-DC MULTI-OUTPUT POWER SUPPLY
- C.-G. DC-DC CONVERTER
- C.-H. OPTIONS
- D. TECHNICAL DICTIONARY
- E. COMPANY PROFILE
- F. BUSINESS MANUAL
- G. INDEX

Computer Power Supply - BRAIN


Control & Mechanism System Power Supply - LIMBS




NAME	TYPE
AC INLET	IEC 320 compliant
FAN	DC12V 60□

Case material SECC

CN NAME	PIN NO.	FUNCTION	MAX CURRENT	COLOR	WIRE TYPE	CONNECTOR TYPE
P 1	1	+3.3V DC	4.0A	BROWN	UL1007	Housing:CP-01120030 Terminal:CP-01100102 (Cvilux) or equivalent
	2	+3.3V DC	4.0A	BROWN	AWG#18	
	3	COM	4.0A	BLACK		
	4	+5VDC	4.0A	RED		
	5	COM	4.0A	BLACK		
	6	+5VDC	4.0A	RED		
	7	COM	4.0A	BLACK		
	8	PWR OK	5mA	ORANGE	AWG#22	
	9	+5V SB	1.2A	VIOLLET	AWG#18	
	10	+12VDC	4.0A	YELLOW		
	11	+3.3V DC	2.0A	BROWN	AWG#22	Terminal:CP-01100105 (Cvilux)
	12	-12VDC	0.5A	BLUE	AWG#18	
	13	COM	4.0A	BLACK		
	14	PS_ON#	1mA	GRAY	AWG#22	
	15	COM	4.0A	BLACK	AWG#18	
	16	COM	4.0A	BLACK		
	17	COM	4.0A	BLACK		
	18					
	19	+5VDC	4.0A	RED		
	20	+5VDC	4.0A	RED		
P 2	2	FAN C	10mA	BLUE		Housing:5557-06R Terminal:5556 (molex) or equivalent
	3					
	4				UL1007	
	5				AWG#22	
	6					
	7					
P 3 P 5 P 6	1	+12VDC	4.0A	YELLOW		Housing:LCP-04 Terminal:SLC221-2.0 (JST) or equivalent
	2	COM	4.0A	BLACK	UL1007	
	3	COM	4.0A	BLACK	AWG#18	
	4	+5VDC	4.0A	RED		
P 4	1	+5VDC	0.5A	RED		Housing:171822-4 Terminal:170204-1 (AMP) or equivalent
	2	COM	0.5A	BLACK	UL1007	
	3	COM	0.5A	BLACK	AWG#22	
	4	+12VDC	0.5A	YELLOW		

Cable				
Page	Photo	Model	Category	Description
B-646		WH2753	AC power cable	AC125V 12A [PSE]

Parts and Unit				
Page	Photo	Model	Category	Description
B-656		ACC2837	Attachment panel	Attachment panel to ATX power supply mounting surface (W×H[mm]=125×63.5)

Other options					
Page	Model	Description	Page	Model	Description
B-652	ACC2637	Automatic Startup Unit	B-650	WH5105	12V 4 pin connector conversion harness (80mm)
B-649	WH2820	20-pin extension harness (600mm)	B-650	WH5105-02	12V 4 pin connector conversion harness (320mm)
B-649	WH2747	20-pin extension harness (450mm)	B-647	WH5055	AT connector conversion harness
B-649	WH2892-02	20-pin extension harness (200mm)	B-647	ACC5046	Harness equipped with PS_ON switch
B-651	WH2812	PCI-E 6 pin connector conversion harness	B-648	ACC5077	PS_ON terminal shorting connector
			B-648	WH5073	PS_ON terminal shorting 20-pin harness

Column 37

### SFX

#### SFX (abbreviation of Small Form Factor)

This is form factor applied together with microATX resulting in half or less volume of ATX power supply. Electric specification follows the fundamental requirement for ATX main board specification, but -5V is not equipped. -5V is mainly supplied to ISA bus expansion cards. As the dimension of power supply has 5 types, confirmation is required to see if even the same specification of SFX is acceptable to the case.

- ① W×H×D(mm)=100×50×125
- ② W×H×D(mm)=100×63.5×125 (Excluding protrusion of fan)
- ③ W×H×D(mm)=125×63.5×100 (Excluding protrusion of fan)
- ④ W×H×D(mm)=100×63.5×125
- ⑤ W×H×D(mm)=150×86×101.4 ⇒ This is called PS3 size and has the same mounting space as ATX(PS/2) size.

Output connector is the same as ATX.

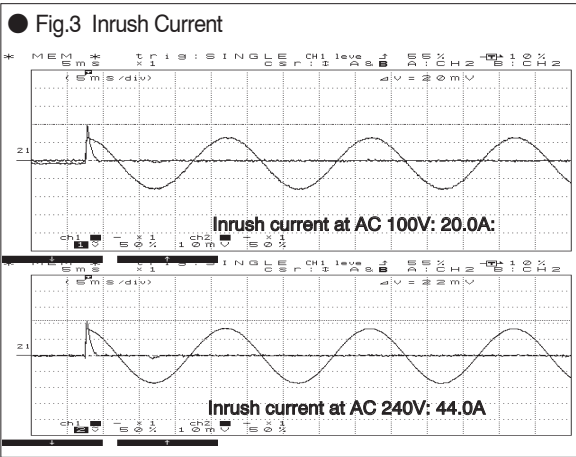
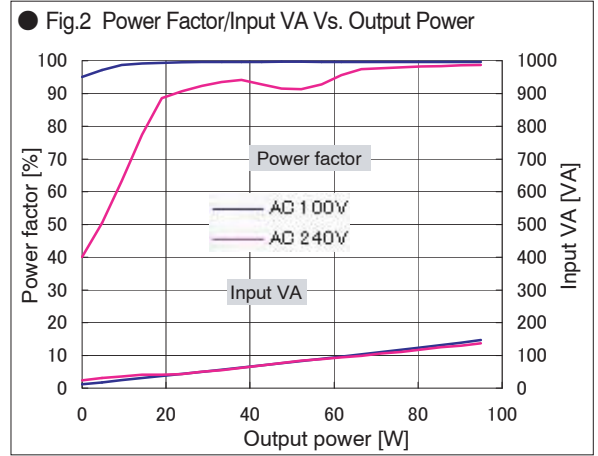
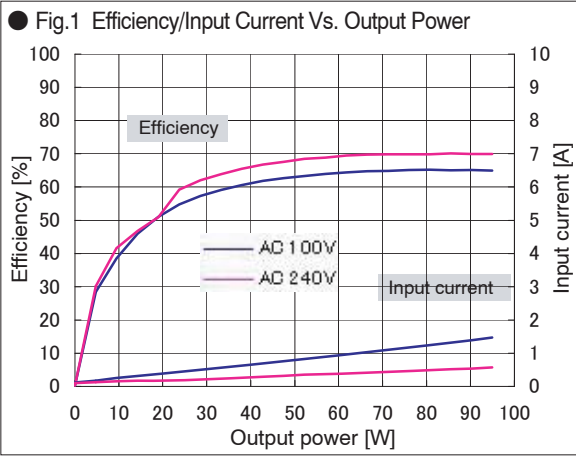
- Main connector (20 pins) ⇒ Changed to 24 pins from SFX12V ver3.0.
- +12V connector
- Peripheral connector
- Floppy drive connector
- S-ATA connector ⇒ Required from SFX12V ver2.3

Computer Power Supply - BRAIN

Control & Mechanism System Power Supply - LIMBS

- A. UPDATE
- B. SELECTION GUIDE
  - B-A PRODUCT PAGE GUIDELINE
  - B-B NONSTOP POWER SUPPLY
  - B-C AC+DC DUAL-INPUT PSU
  - B-D GENERAL PURPOSE PC PSU
  - B-E GENERAL PURPOSE REDUNDANT PSU
  - B-F OPTIONS
- C. SELECTION GUIDE
  - C-A PRODUCT PAGE GUIDELINE
  - C-B AC-DC SINGLE OUTPUT NONSTOP PSU
  - C-C AC-DC MULTI-OUTPUT NONSTOP PSU
  - C-D AC-DC SINGLE OUTPUT POWER SUPPLY
  - C-E AC-DC MULTI-OUTPUT POWER SUPPLY
  - C-F DC-DC CONVERTER
  - C-G OPTIONS
- D. TECHNICAL DICTIONARY
- E. COMPANY PROFILE
- F. BUSINESS MANUAL
- G. INDEX

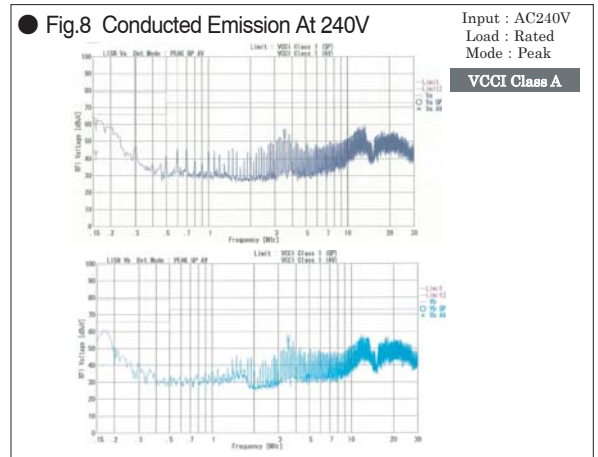
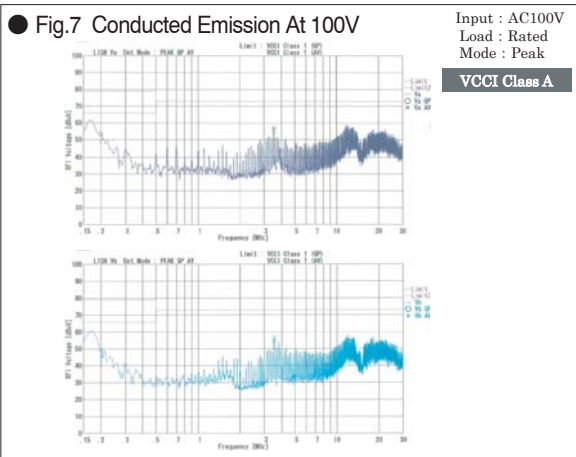
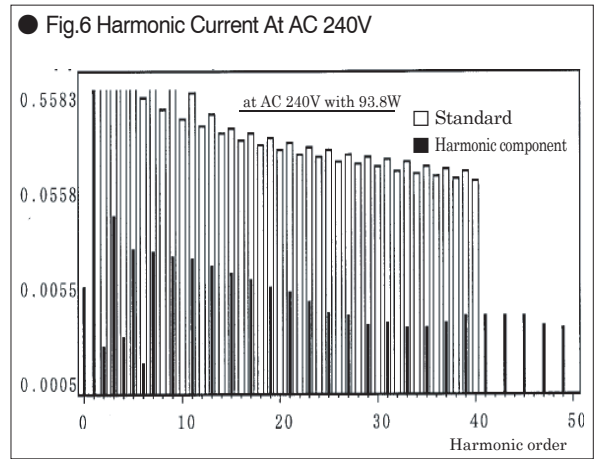
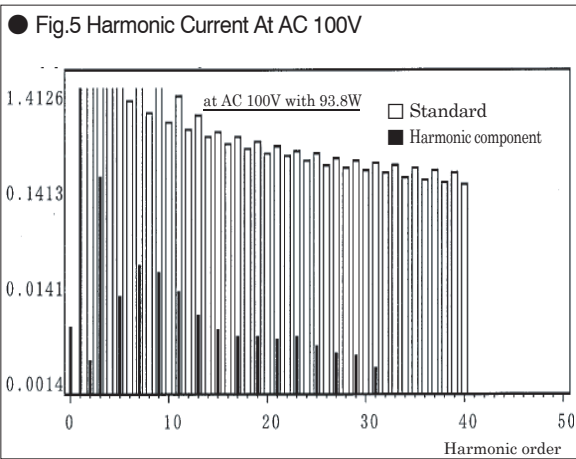
**C**haracteristics Data (Examples of actual measurement)

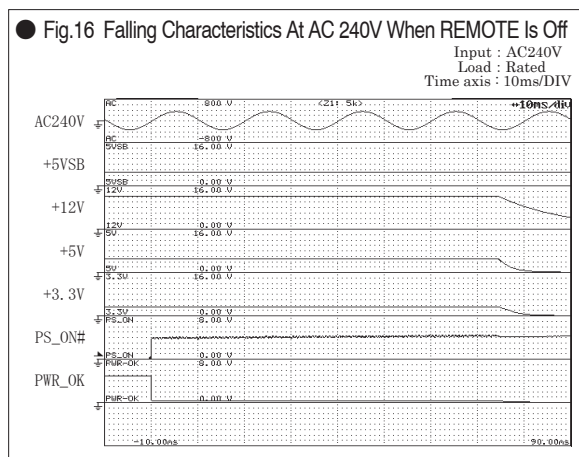
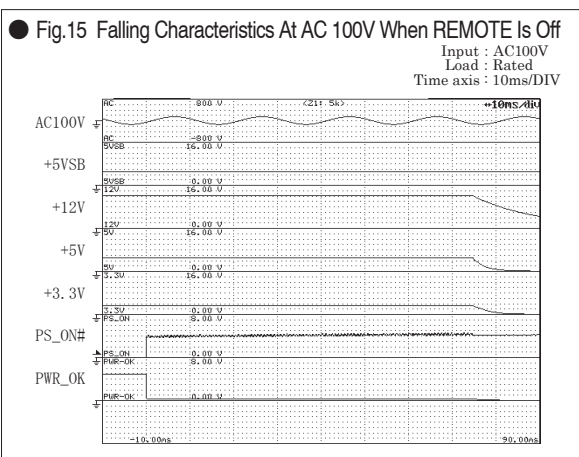
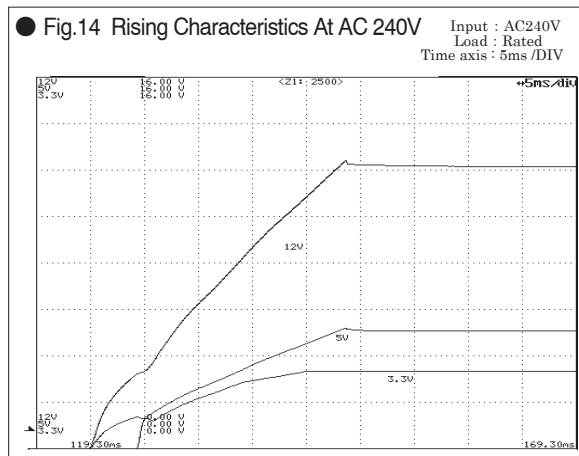
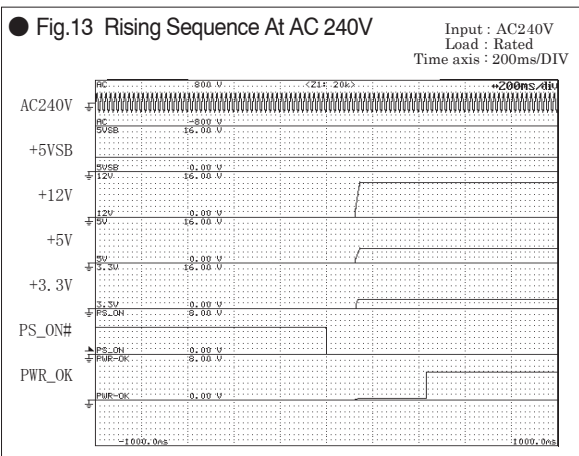
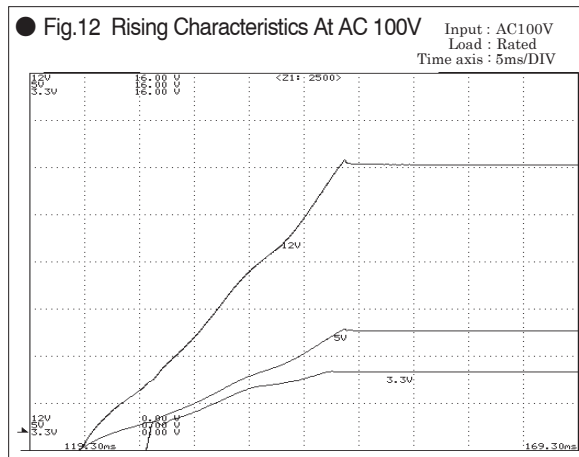
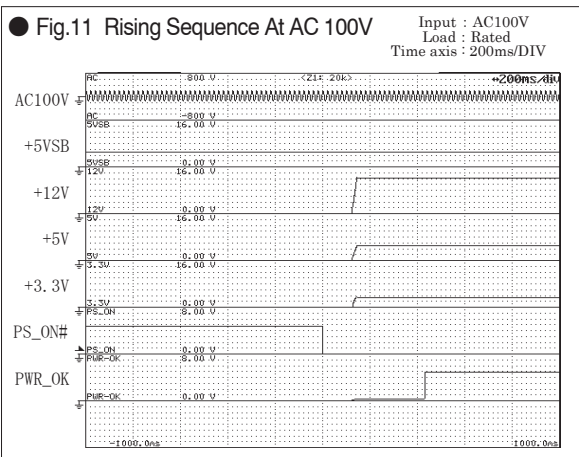
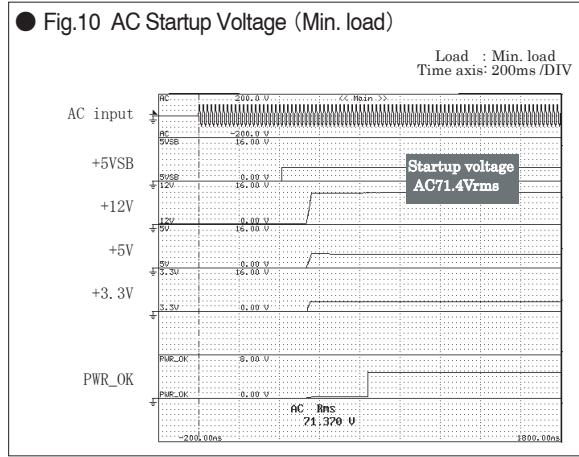
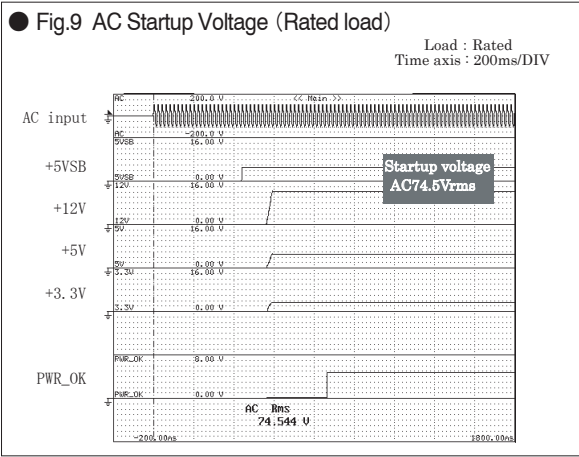


**Fig.4 Leakage Current**

Input : AC100, 240V  
Load : Rated load and Min. load

	Rated load	Min. load
AC 100V	0.38mA	0.30mA
AC 240V	0.71mA	0.73mA



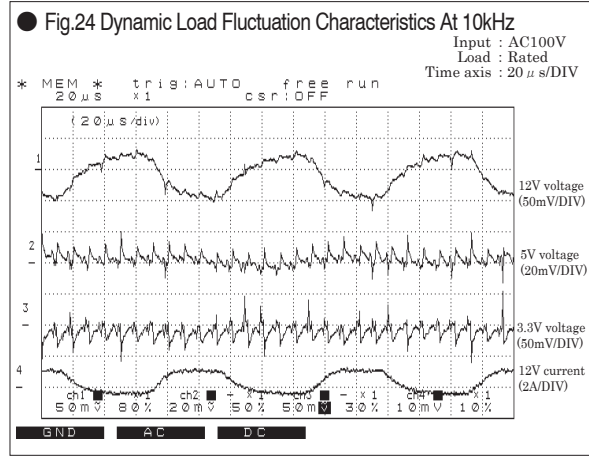
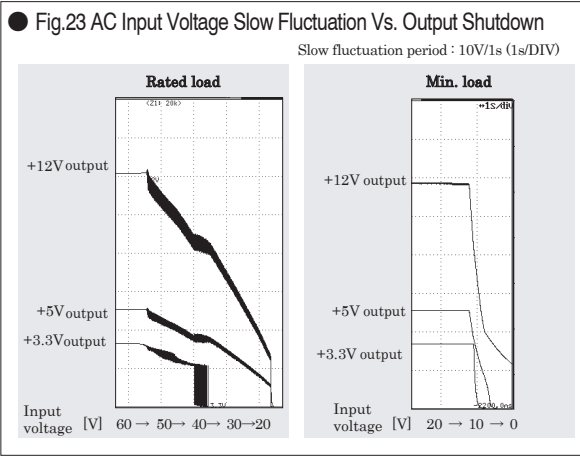
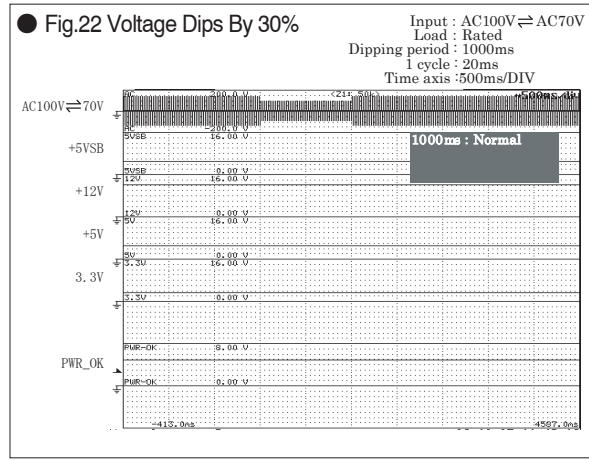
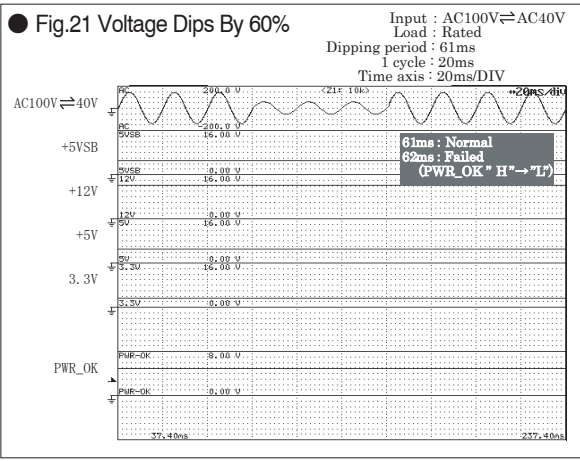
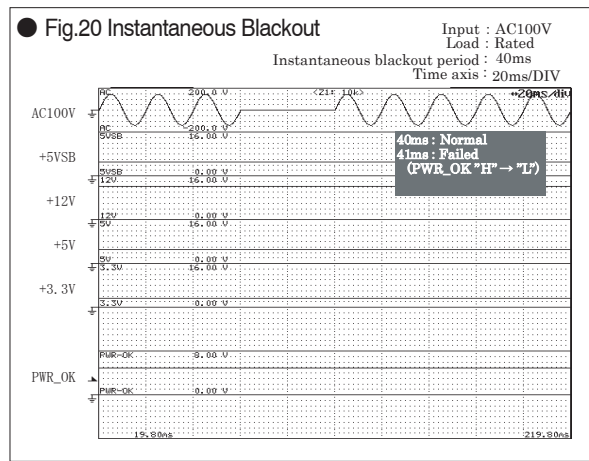
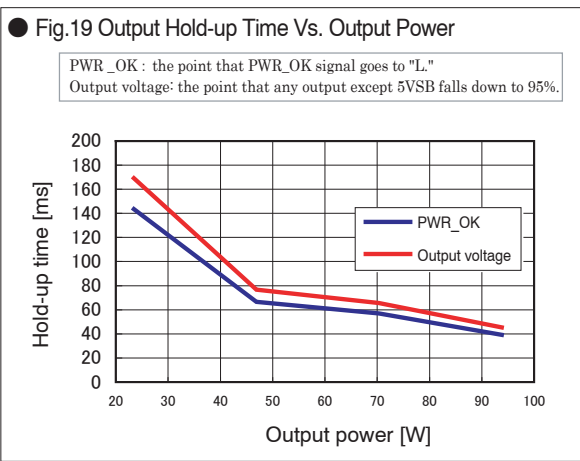
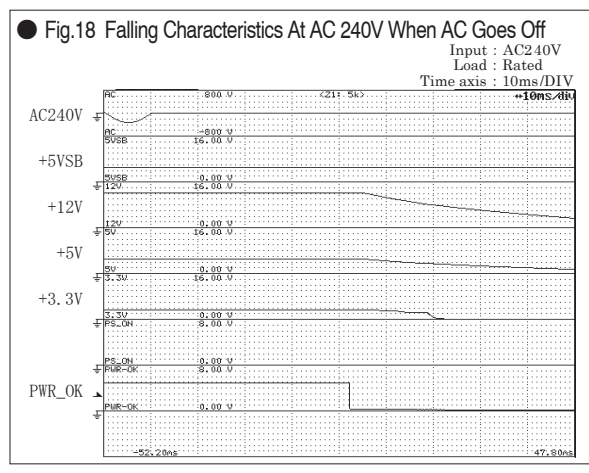
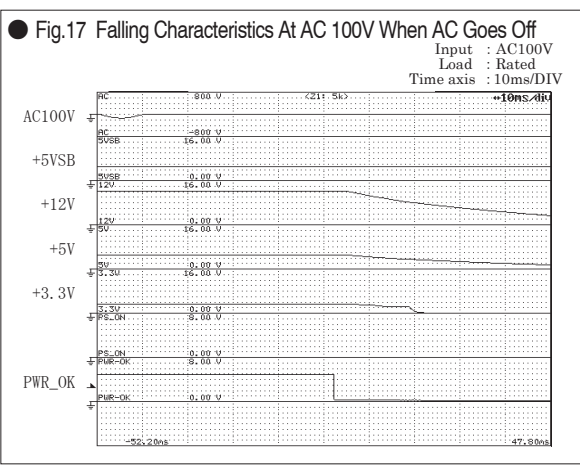


Computer Power Supply - BRAIN

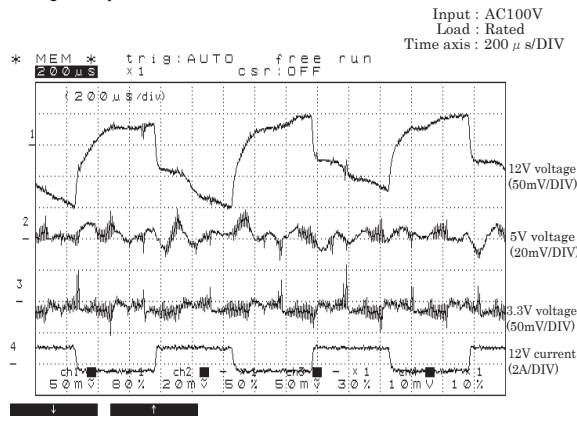
Control & Mechanism System Power Supply - LIMBS

A.	UPDATE
B.-A.	SELECTION GUIDE
B.-B.	PRODUCT PAGE GUIDELINE
B.-C.	NONSTOP POWER SUPPLY
B.-D.	AC+DC DUAL-INPUT PSU
B.-E.	GENERAL PURPOSE PC PSU
B.-F.	GENERAL PURPOSE REDUNDANT PSU
B.-G.	OPTIONS
C.-A.	SELECTION GUIDE
C.-B.	PRODUCT PAGE GUIDELINE
C.-C.	AC-DC SINGLE OUTPUT NONSTOP PSU
C.-D.	AC-DC MULTI-OUTPUT NONSTOP PSU
C.-E.	AC-DC SINGLE OUTPUT POWER SUPPLY
C.-F.	AC-DC MULTI-OUTPUT POWER SUPPLY
C.-G.	DC-DC CONVERTER
C.-H.	OPTIONS
D.	TECHNICAL DICTIONARY
E.	COMPANY PROFILE
F.	BUSINESS MANUAL
G.	INDEX

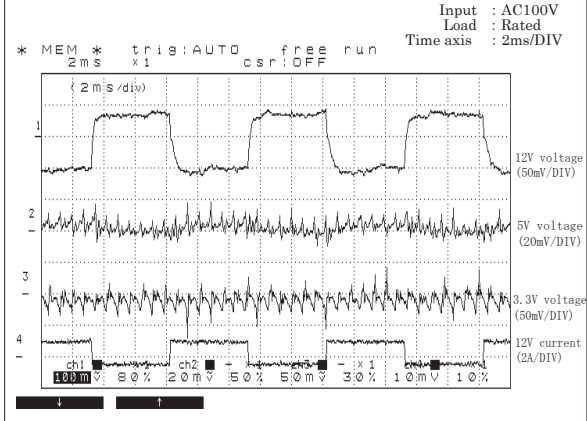
Characteristics Data (Examples of actual measurement)



● Fig.25 Dynamic Load Fluctuation Characteristics At 1kHz



● Fig.26 Dynamic Load Fluctuation Characteristics At 100Hz

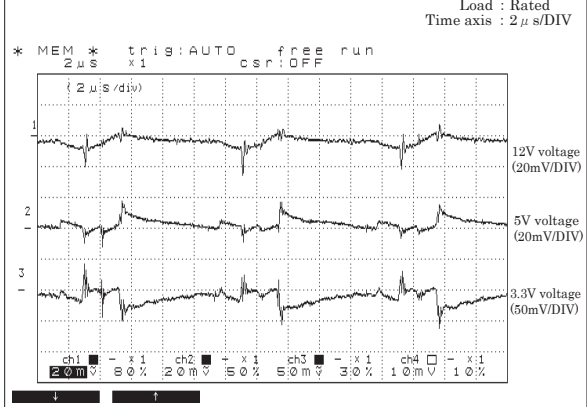


● Fig.27 Output Voltage Regulation

SPEC.	Min. load	Rated load	Peak load
12V load	0A	1.5A	4.8A
5V load	1A	10A	12A
3.3V load	0A	6A	6A

AC input	AC 85V	AC 100V	AC 132V	AC 176V	AC 240V	AC 264V
12V load (min.)	11.700 V	11.706 V	11.701 V	11.709 V	11.711 V	11.711 V
12V load (Rated)	12.199 V	12.198 V	12.198 V	12.198 V	12.199 V	12.198 V
12V load (Peak)	12.037 V	12.037 V	12.037 V	12.037 V	12.036 V	12.037 V
5V load (min.)	5.118 V	5.118 V	5.118 V	5.117 V	5.117 V	5.117 V
5V load (Rated)	5.061 V	5.060 V	5.060 V	5.060 V	5.060 V	5.060 V
5V load (Peak)	5.057 V	5.056 V	5.056 V	5.056 V	5.056 V	5.056 V
3.3V load (min.)	3.369 V	3.369 V	3.369 V	3.369 V	3.369 V	3.369 V
3.3V load (Rated)	3.331 V	3.331 V	3.331 V	3.331 V	3.331 V	3.329 V
3.3V load (Peak)	3.329 V	3.329 V	3.329 V	3.329 V	3.329 V	3.329 V

● Fig.30 Ripple and Spike Voltage



● Fig.29 Ambient Temperature Vs. Lifetime Expectancy

■ Electrolytic capacitors

Input : AC100V  
Load : Rated

Temp. of intake air	20°C	30°C	40°C	50°C
Lifetime expectancy (yr)	approx. 45	approx. 22	approx. 11	approx. 5.6

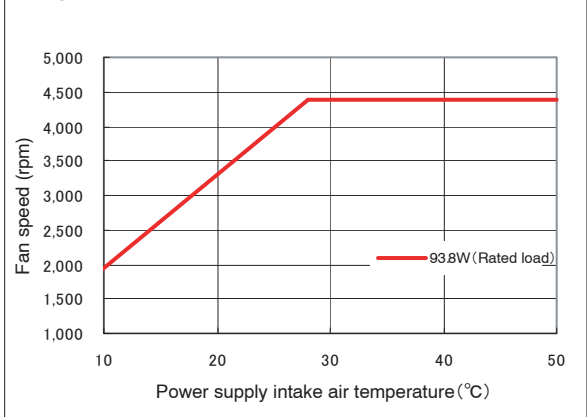
※ Lifetime shall be 15 years at longest due to deterioration of sealing plates. UOM: Year

■ FAN

Ambient temp. of Fan	20°C ± 15°C
Lifetime expectancy (yr)	approx. 6.9

UOM: Year

● Fig.30 Intake Air Temperature Vs. Fan Speed



Computer Power Supply - BRAIN

Control & Mechanism System Power Supply - LIMBS

A.	UPDATE
B.-A	SELECTION GUIDE
B.-B	PRODUCT PAGE GUIDELINE
B.-C	NONSTOP POWER SUPPLY
B.-D	AC-DC DUAL-INPUT PSU
B.-E	GENERAL PURPOSE PC PSU
B.-F	GENERAL PURPOSE REDUNDANT PSU
B.-G	OPTIONS
C.-A	SELECTION GUIDE
C.-B	PRODUCT PAGE GUIDELINE
C.-C	AC-DC SINGLE OUTPUT NONSTOP PSU
C.-D	AC-DC MULTI-OUTPUT NONSTOP PSU
C.-E	AC-DC SINGLE OUTPUT POWER SUPPLY
C.-F	AC-DC MULTI-OUTPUT POWER SUPPLY
C.-G	DC-DC CONVERTER
C.-H	OPTIONS
D.	TECHNICAL DICTIONARY
E.	COMPANY PROFILE
F.	BUSINESS MANUAL
G.	INDEX