

| | |
|----------------------------------|------|
| UPDATE | A. |
| SELECTION GUIDE | B.-A |
| PRODUCT PAGE GUIDELINE | B.-B |
| NONSTOP POWER SUPPLY | B.-C |
| AC+DC DUAL-INPUT PSU | B.-D |
| GENERAL PURPOSE PC PSU | B.-E |
| GENERAL PURPOSE REDUNDANT PSU | B.-F |
| OPTIONS | B.-G |
| SELECTION GUIDE | C.-A |
| PRODUCT PAGE GUIDELINE | C.-B |
| AC-DC SINGLE OUTPUT NONSTOP PSU | C.-C |
| AC-DC MULTI-OUTPUT NONSTOP PSU | C.-D |
| AC-DC SINGLE OUTPUT POWER SUPPLY | C.-E |
| AC-DC MULTI-OUTPUT POWER SUPPLY | C.-F |
| DC-DC CONVERTER | C.-G |
| OPTIONS | C.-H |
| TECHNICAL DICTIONARY | D. |
| COMPANY PROFILE | E. |
| BUSINESS MANUAL | F. |
| INDEX | G. |

Computer Power Supply - BRAIN

Control & Mechanism System Power Supply - LIMBS

System rack power supply PCSR-300 series

Perfect load balance operation & Hot swappable full redundant power supply



PCRS-300-X2H

PCRS-300-X2V

Redundant

| | |
|--------------------------------|---------------------|
| Continuous Max. 300W | Peak 302W |
|--------------------------------|---------------------|

| Model | Description | Stock | Standard price before Tax |
|--------------|--|--|---------------------------|
| PCRS-300-X2H | Horizontal type redundant power supply | Lead time: 30 days for 1 to 5 pcs., 100 days for 6 pcs. or more. | ¥95, 700 |
| PCRS-300-X2V | Vertical type redundant power supply | Lead time: 30 days for 1 to 5 pcs., 100 days for 6 pcs. or more. | ¥95, 700 |
| PCRS-300-S2S | Power supply module | Lead time: 30 days for 1 to 5 pcs., 100 days for 6 pcs. or more. | ¥36, 000 |

| | | | |
|--|--|--|---|
| Model name coding PCRS - 300 - * 2 * ① ② ③ ④ ⑤ | | ① Series name ② Output power ③ X: ATX output S: Power supply module | ④ +3.3V equipped ⑤ S: Standard H: Standard horizontal type redundant power supply V: Standard vertical type redundant power supply |
|--|--|--|---|

Features

- Perfect load balance control by current detection
- Hot swappable
- Voltage drop of Oring diodes compensated by feedback
- Output voltage regulation is improved by detecting the voltage on Anode side of Oring diodes.
- Thermo-sensing speed control fan equipped
- Silence-oriented as fan speed changes according to operating temperature and load conditions.

N+1 redundant configuration
 PCSR series makes easily parallel operation to meet customers' system and N+1 redundant operation available as it has Oring diodes built-in. Also, perfect load balance circuit prevents the power supply from deterioration of one side module only.

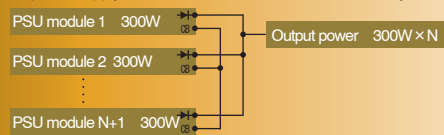

Perfect load balance circuit

The load current of one module is detected to control output voltage of another module for load equalization. Thus, stress to the power supply is reduced for long-life operation.

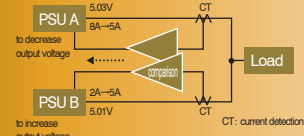

Refer to B-B1 "Product page guideline" for icons.

| | | | | | |
|-------------------|-----|-----|------------|----|-----|
| Safety standard | UL | CSA | EN | CE | CCC |
| Reliability grade | HFA | FA | HOA | OA | |

Function

DC start
RS 232C
USB
TTL
PFC
Silence
5VSB FAN
TSFC FAN
Connection
Fit for Pent
Full Draining

Input

| | |
|----------|-------------------------------|
| AC input | 90V to 264V (Worldwide range) |
|----------|-------------------------------|

Output

| Output voltage | +3.3V | +5V | +12V | -5V | -12V | +5VSB |
|--|------------------|-----|-------------------|------|------|----------------------|
| Max. current/Max. power (continuous) | 28A Total 35A | 35A | 15A Total 290W | 0.5A | 0.8A | 2A Total 300W |
| Peak current/Peak power (within 5 seconds) | 28A Total 40A | 35A | 18A Total 290W | 0.5A | 0.8A | 2.5A Total 302.5W |
| Min. load | 0A | 2A | 0.1A | 0A | 0A | 0.1A |

Dimension

| | | |
|----------------|--------------|-----------------|
| W × H × D (mm) | PCRS-300-X2H | 360 × 83 × 250 |
| | PCRS-300-X2V | 180 × 165 × 250 |

Output connectors

20 Pin
24 Pin
AT
12V
AUX
Processor
×6
×1
S-ATA
PCI-E

※ PCSR-300-X2H and PCSR-300-X2V only

We recommend you Nipron's full redundant power supply for whom perfect redundant system is needed. A little bit larger though...

General Specification; All items are provided at normal temperature and humidity unless otherwise specified.

Specification for PCSR-300-X2H, and PCSR-300-X2V

| | Page | Items | Specification | Measurements, etc. | | |
|-------------|------------|---|---|---|--|--|
| AC Input | D-6(1) | Rated voltage | AC100 - 240V (AC 90V - 264V*) Data on B-F19 Fig.10-11 | Worldwide range * Harmonic regulation shall cover input voltage up to 253V. | | |
| | D-6(2) | Frequency | 50/60Hz | 47 to 63Hz | | |
| | D-6(3) | Efficiency | 65% typical at AC 100V, 68% typical at AC 240V Data on B-F18 Fig.2 | at rated Output | | |
| | D-6(4) | Power factor | 98% typical at AC 100V, 95% typical at AC 240V Data on B-F18 Fig.3 | | | |
| | D-6(5) | Inrush current | 80A peak (40A per one module) Data on B-F18 Fig.4 | at rated Load. Input reclosing interval shall be 10 sec. min. | | |
| | D-6(6) | Input VA | 500VA typical Data on B-F18 Fig.3 | at rated Output | | |
| Output | — | Rated voltage | +3.3V +5V +12V -5V -12V +5VSB | | | |
| | — | Rated current | 15A 20A 10A 0.5A 0.8A 2A | | | |
| | D-6(8) | Max. Current/Power | 28A 35A 15A 0.5A 0.8A 2A 35A max. 290W max. 300W max. | Max. output power: 300W | | |
| | D-6(9) | Peak Current/Power | 28A 35A 18A 0.5A 0.8A 2.5A 40A max. 290W max. 302.5W max. | Peak output power: 302.5W | | |
| | D-6(10) | Min. load | 0A* 2A* 0.1A 0A 0A 0.1A | * or total power of +3.3V and +5V shall be 10W min. | | |
| | D-6(11)-⑧ | Total Voltage Accuracy (%) | ±5 max. ±5 max. ±5 max. ±10 max. ±10 max. ±6 max. | Total accuracy of Temperature, Input, and Load fluctuation | | |
| | D-7(12) | Max. Ripple Voltage (mVp-p) | 50 max. 50 max. 120 max. 50 max. 120 max. 50 max. | To be measured on a test board with a 47μF electrolytic capacitor with 100MHz oscilloscope | | |
| | D-7(12) | Max. Spike Voltage (mVp-p) | 100 max. 100 max. 170 max. 100 max. 170 max. 100 max. | The test board shall be away from load lines and within 150mm from output terminals. Data on B-F21 Fig.29 | | |
| | — | Current balancing | Available (Note) | | | N/A |
| | Protection | D-7(13) | Overcurrent Protection | OCP point (A) | 58 min. — 38 min. | — — — |
| Method | | Hold-down current limiting → all output shutdown except +5VSB | | Hold-down current limiting | Blocking oscillation | at min. load for all outputs except the output to be measured with 10A load of +12V. |
| Recovery | | Reclosing of Input (Reclosing interval shall be 10 sec. min.) or reclosing of PS_ON# signal | | Automatic recovery | | |
| D-7(14) | | Overvoltage Protection | OVP point (V) | 3.7 ~ 4.3 5.6 ~ 7.0 13.2 ~ 15.6 | — — — | Protection does not work when external overvoltage is applied. |
| Method | | | all output shutdown except +5VSB | — — — | Only the module which occurs overvoltage, and of which fan stops shuts down outputs. | |
| — | | Fan stop protection | All outputs shut down except +5VSB when fan stops due to failure. | | | Reclosing of Input (Reclosing interval shall be 10 sec. min. or reclosing of PS_ON# signal for recovery) |
| Environment | D-7(16) | Operating Temp. and Humidity | 0-60°C* / 20-90% | | | * See <Fig.1> Temperature derating below. No condensation |
| | D-7(17) | Storage Temp. and Humidity | -20-70°C / 10-95% | | | No condensation |
| | D-7(18) | Vibration | To endure 10 times the condition of displacement amplitude: 0.075mm and vibration frequency: 10-55Hz in each direction of X, Y, and Z. | | | JIS-C-0040-1999 at no operation |
| | D-7(19) | Mechanical strength (surface dropping) | Lift one bottom edge of the unit up to 50mm high with the opposite edge placed on the table, and let it fall. Repeat 3 times for each of four bottom edges, and no malfunction shall be observed. | | | JIS-C-0043-1995 at no operation |
| Insulation | D-7(20) | Dielectric Strength | AC 1500V for 1 minute between AC input and DC-output/FG | | | Cut-off current: 40mA max. at normal temp. and humidity |
| | D-7(21) | Insulation Resistance | 50MΩ min. between AC input and DC-output/FG 50MΩ min. between DC-output and FG | | | At DC 500V at normal temp. and humidity |
| | D-7(22) | Leakage current | 1.5mA max. at AC 100V / 3.5mA max. at AC 240V Data on B-F18 Fig.5 | | | at normal temperature and humidity |
| EMC | D-7(23) | Line Noise Immunity | ±2000V (Pulse width: 100/1000ns, Cycle period: 30 to 100Hz, Normal/Common mode, Positive/Negative polarity for one minute) | | | To be measured with INS-410 There shall be no DC-component fluctuation and no malfunction of output. |
| | D-7(24) | Electrostatic Discharge | EN61000-4-2 compliant | | | |
| | D-7(25) | Radiated, radio-frequency, electromagnetic field immunity | EN61000-4-3 compliant | | | |
| | D-7(26) | Fast Transient Burst | EN61000-4-4 compliant | | | |
| | D-7(27) | Lightning Surge | EN61000-4-5 compliant | | | |
| | D-7(28) | Conductive Radio-Frequency Electromagnetic Field | EN61000-4-6 compliant | | | |
| | D-7(29) | Power Frequency Magnetic Field Immunity | EN61000-4-8 compliant | | | |
| | D-8(30) | Voltage Dips and Fluctuation | EN61000-4-11 compliant Data on B-F20 Fig. 22 | | | |
| | D-8(31) | Conducted Emission | VCCI-A compliant | | | To be measured with single power supply |
| | D-8(32) | Harmonic Current Regulation | IEC61000-3-2クラスD compliant Data on B-F18 Fig.6-7 | | | Input voltage range shall be 90 to 253V. |
| Others | D-8(1-6) | Safety Standard | IEC69050 compliant | | | |
| | D-8(34) | Cooling System | Forced air cooling with thermo-sensing speed control fan built in | | | Fan speed changes due to operating temp. and load condition. |
| | D-8(35) | Output GND Grounding | Capacitor earthing | | | |
| | D-8(38) | Output Hold-up Time | Hold-up time is 17ms min. before PWR_OK is delivered after AC turns off. Data on B-F20 Fig.20 | | | at rated Output |
| | F-3 | Reliability Grade | HOA | | | To follow our standard |
| | D-8(41) | MTBF | 100,000 H min | | | To follow EIAJ RCR-9102 and MTBF calculation equation of redundant system for no repair |
| | — | Weight | 8.5 kg typical (PCSR-300-X2H), 8.0 kg typical (PCSR-300-X2V) | | | 2.7 Kg typical for PCSR-300-S2S |
| F-3 | Warranty | One year after delivery. However, if any faults belong to us, the defective unit shall be repaired or replaced at our cost. | | | Except when wrong operation is conducted out of product specification, etc. | |

(Note) Load current at measurement shall be 2 times of rated current for +3.3V,+5V,and +12V, and rated current for -5V,-12V,and +5VSB. At this time, output current at measurement for +3.3V,+5V,and +12V of each module shall be ±20% max. of rated current.

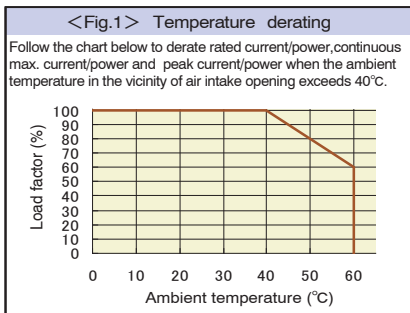

Computer Power Supply - BRAIN

Control & Mechanism System Power Supply - LIMBS

- A. UPDATE
- B. SELECTION GUIDE
- B. PRODUCT PAGE GUIDELINE
- B. NONSTOP POWER SUPPLY
- B. AC+DC DUAL-INPUT PSU
- B. GENERAL PURPOSE PC PSU
- B. GENERAL PURPOSE REDUNDANT PSU
- B. OPTIONS
- C. SELECTION GUIDE
- C. PRODUCT PAGE GUIDELINE
- C. AC-DC SINGLE OUTPUT NONSTOP PSU
- C. AC-DC MULTI-OUTPUT NONSTOP PSU
- C. AC-DC SINGLE OUTPUT POWER SUPPLY
- C. AC-DC MULTI-OUTPUT POWER SUPPLY
- C. DC-DC CONVERTER
- C. OPTIONS
- D. TECHNICAL DICTIONARY
- E. COMPANY PROFILE
- F. BUSINESS MANUAL
- G. INDEX

Signal Input/Output Specification (Items are provided at normal temperature and humidity unless otherwise specified.)

Specification for PCSR-300-X2H, PCSR-300-X2V

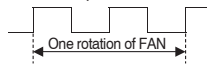
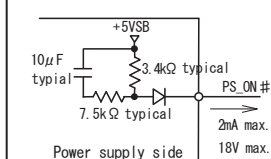
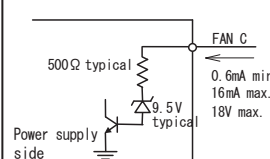
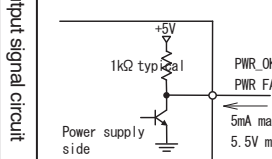
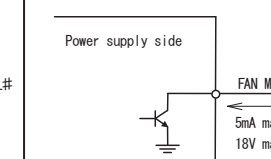
| Items | Specification | Note | | | |
|--|---|--|--|--|---|
| Input signal | Output ON/OFF control signal (PS_ON#) | Upon receipt of 'L', +3.3V, +5V, +12V, -5V, and -12V are delivered. Upon receipt of 'H' or 'OPEN', +3.3V, +5V, +12V, -5V, and -12V shut down. Also, protection circuit is activated to reset latch lock circuit when outputs are shut down status. | Signal input between P1 connector pin 14 and COM pin | | |
| | External control of fan speed (FAN C) | Fan operates at top speed at 10.5V +5% or more of input voltage. In case of lower input voltage than that or no input, the internal control comes first. | P11 connector pin 6 | | |
| Output signal | Normal output signal (PWR_OK) | 'H' is delivered when all outputs of either of the two modules are normal. | P1 connector pin 8 | | |
| | Output shutdown alarm (PWR FAIL#1,2) | When output of either of two modules shuts down due to failure, PWR_FAIL# signal of the module in question goes to 'L', and LED display (Green) of the module turns off. Also, when the outputs of the two modules shut down by PS_ON# signal, both modules delivers 'L' and output display LED turns off as well. | PWR FAIL#1: P11 connector pin 1 PWR FAIL#2: P11 connector pin 2 | | |
| | Fan speed detection signal (FAN M1,2) | Two-cycle pulse signal per one rotation of fan is delivered from FAN M terminal respectively. (OPEN collector output) Duty ratio of the pulse shall be 0.5 typical. (The lower the speed is, the longer the interval of the signal, and vice versa). At fan failure or halt, the signal remains 'L' or 'OPEN.' | P11 connector pin 4 and 5  | | |
| PSU module connection notice (PRESENT#1,2) | 'L' signal is delivered when PSU module is connected. (PRESENT# signal pin directly connected to GND inside PSU.) | P11 connector pin 7 and 8 | | | |
| Signal Circuit | | | | | |
| Input signal circuit | (PS_ON#) | (FAN C) | Output signal circuit | (PWR_OK), (PWR FAIL#1, 2) | (FAN M1, 2) |
| |  |  | |  |  |

Sequence Timing Chart

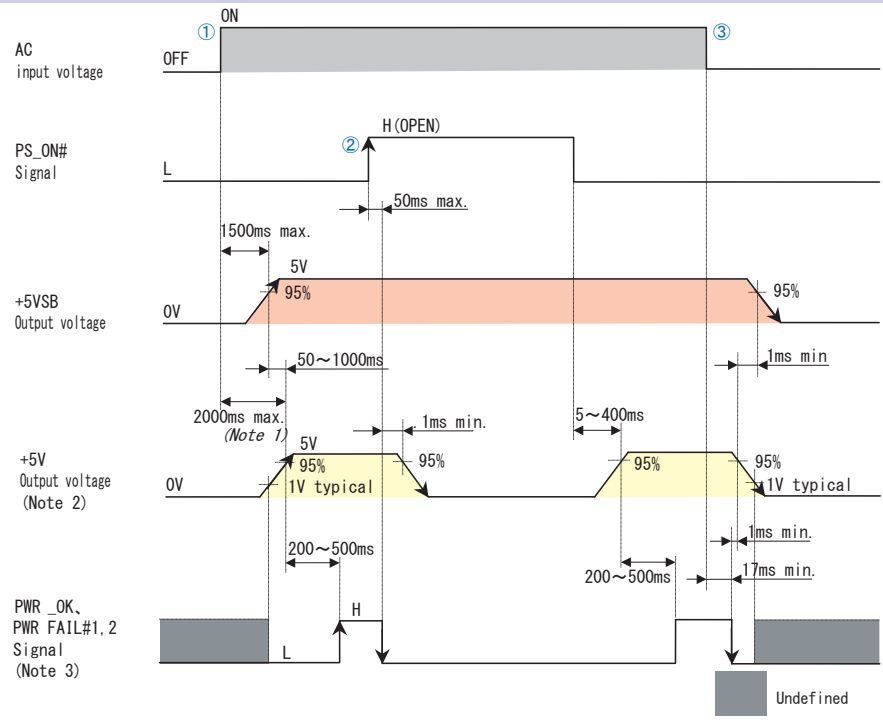

Note 1: Provided that reclosing interval after input turns off 10 sec. or longer.
 Note 2: All outputs except CH2(+5V) shall follow this timing other than voltage value, and rise time difference from CH2(+5V) shall be 50ms max., and output voltage level difference between CH2(+5V) and CH3(+12V) voltage level at rising shall be the level of CH1(+3.3V) or higher. Also, the voltage level difference between CH2(+5V) and CH1(+3.3V) shall be 2.25V or less. In addition, falling order and voltage level difference between each output at falling shall not be provided.
 Note 3: Rising and Falling time of signals shall be 100µs or less provided that no capacitive load shall be connected to signal output terminals.

① All outputs start up at PS_ON# "L" status when AC input turns on. Also, PWR_OK goes to "H"(OPEN) 200 to 500ms after +5V has started up.
 ② All outputs except +5VSB shut down upon receipt of PS_ON#"H"(OPEN)."
 ③ PWR_OK goes to 'L' 17ms or longer after blackout. +5V and +5VSB shut down 1ms or longer after that.

Block Diagram

PCSR-300-X2H/PCSR-300-X2V

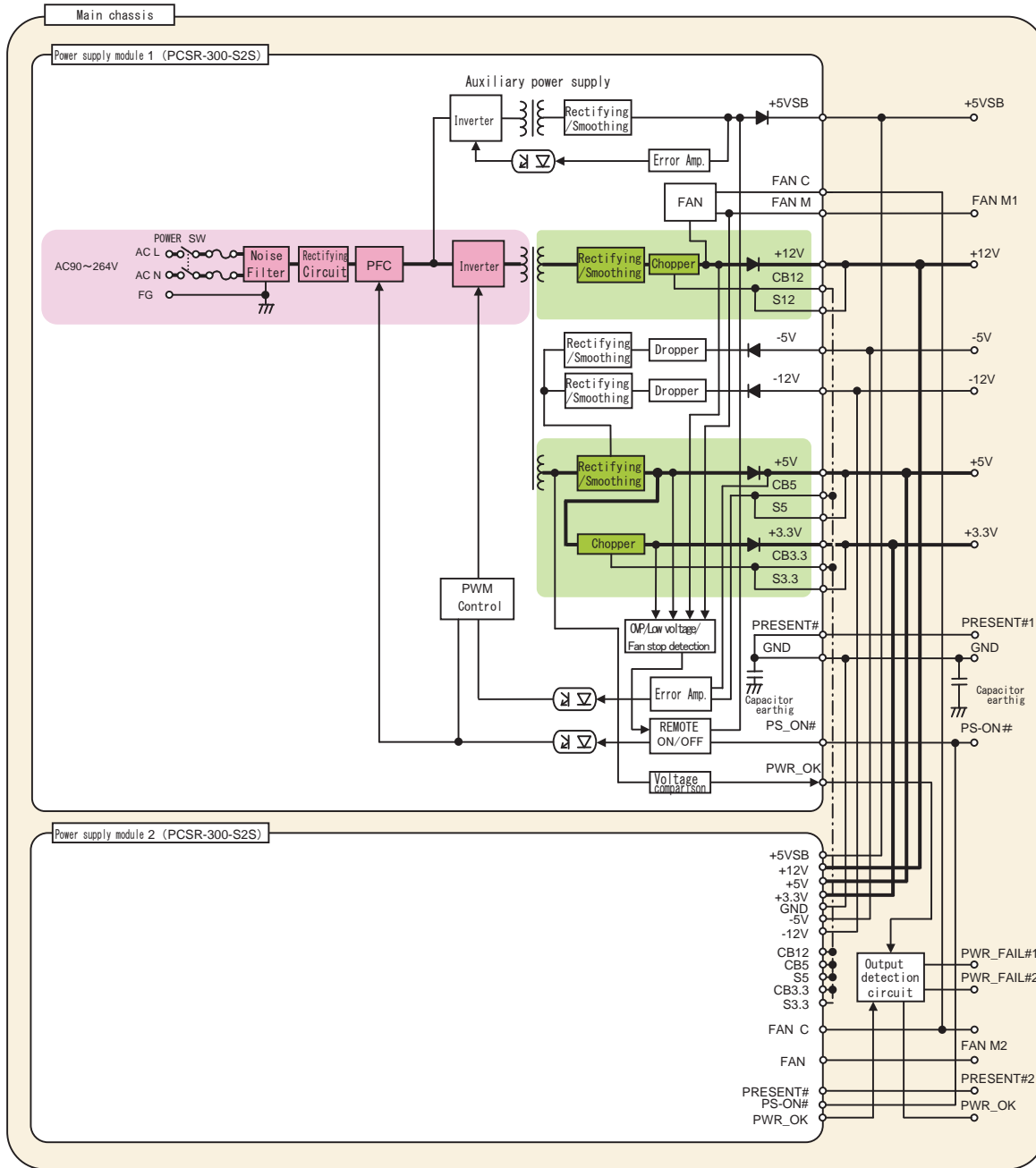

Computer Power Supply - BRAIN

Control & Mechanism System Power Supply - LIMBS

- A. UPDATE
- B.-A. SELECTION GUIDE
- B.-B. PRODUCT PAGE GUIDELINE
- B.-C. NONSTOP POWER SUPPLY
- B.-D. AC+DC DUAL-INPUT PSU
- B.-E. GENERAL PURPOSE PC PSU
- B.-F. GENERAL PURPOSE REDUNDANT PSU
- B.-G. OPTIONS
- C.-A. SELECTION GUIDE
- C.-B. PRODUCT PAGE GUIDELINE
- C.-C. AC/DC SINGLE OUTPUT NONSTOP PSU
- C.-D. AC/DC MULTI-OUTPUT NONSTOP PSU
- C.-E. AC/DC SINGLE OUTPUT POWER SUPPLY
- C.-F. AC/DC MULTI-OUTPUT POWER SUPPLY
- C.-G. DC-DC CONVERTER
- C.-H. OPTIONS

Internal structure

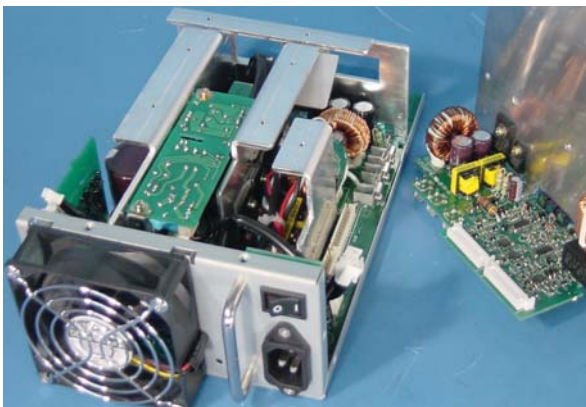

Outline Drawing / Output harness drawing

PCSR-300-X2V

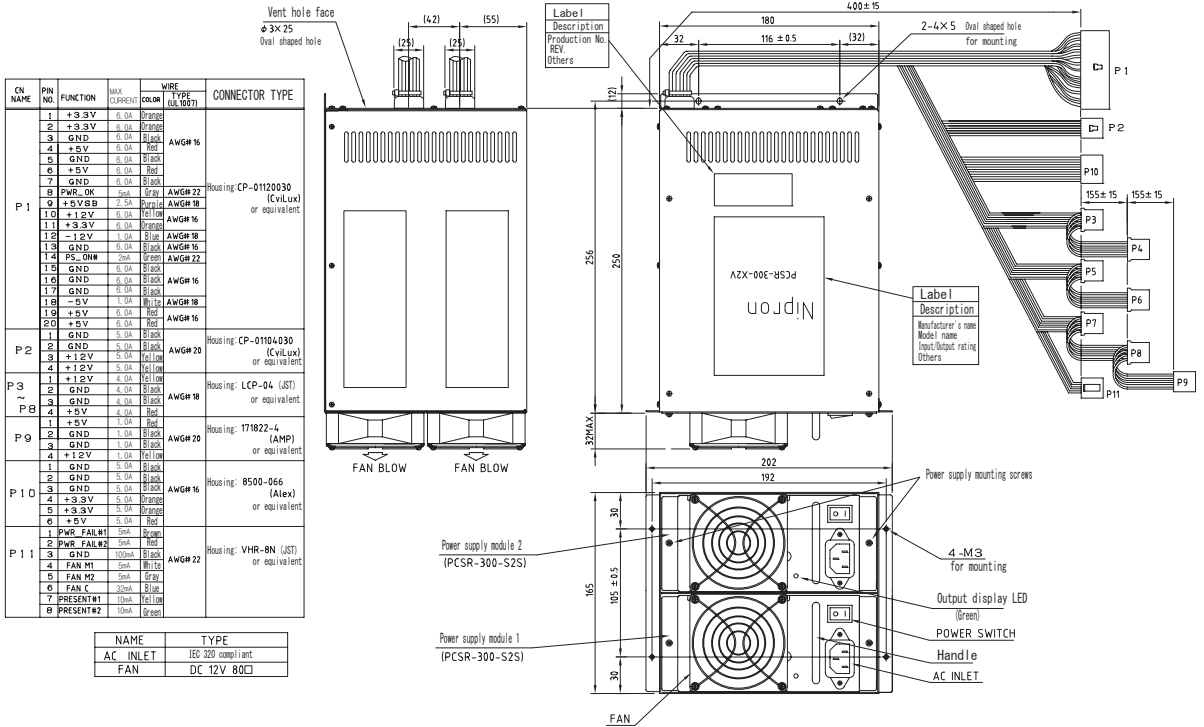

※ Dimensional tolerance shall be ± 1 unless otherwise specified.

PCSR-300-X2H

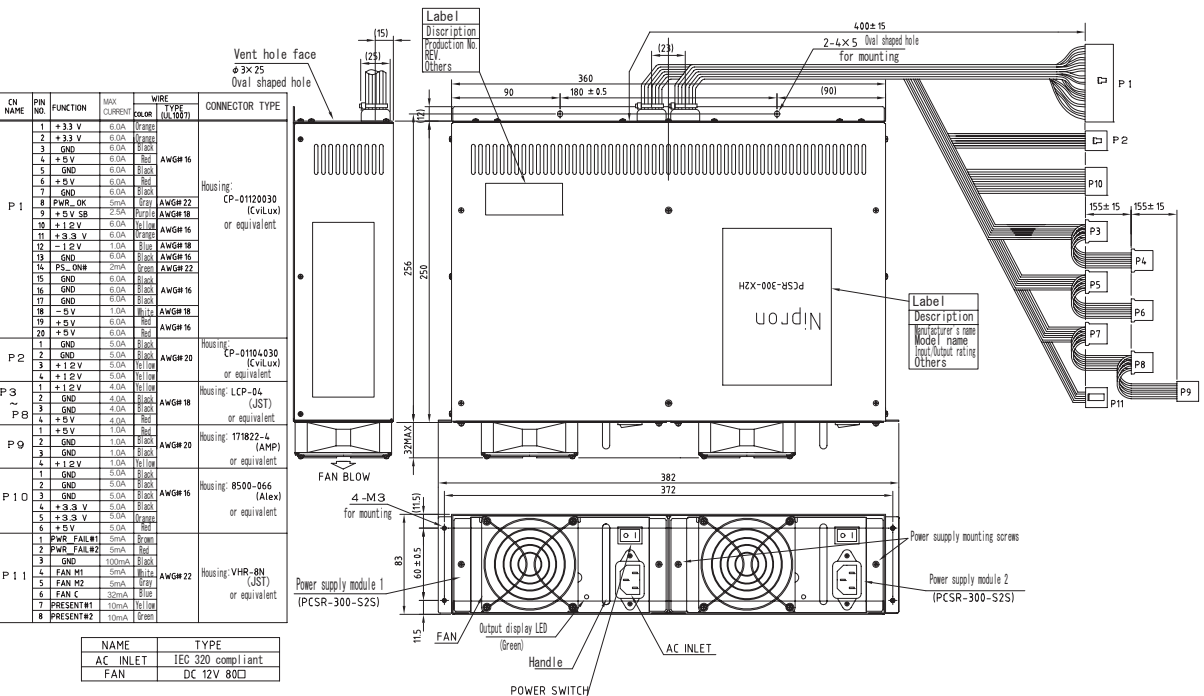

※ Dimensional tolerance shall be ± 1 unless otherwise specified.

PCSR-300-S2S

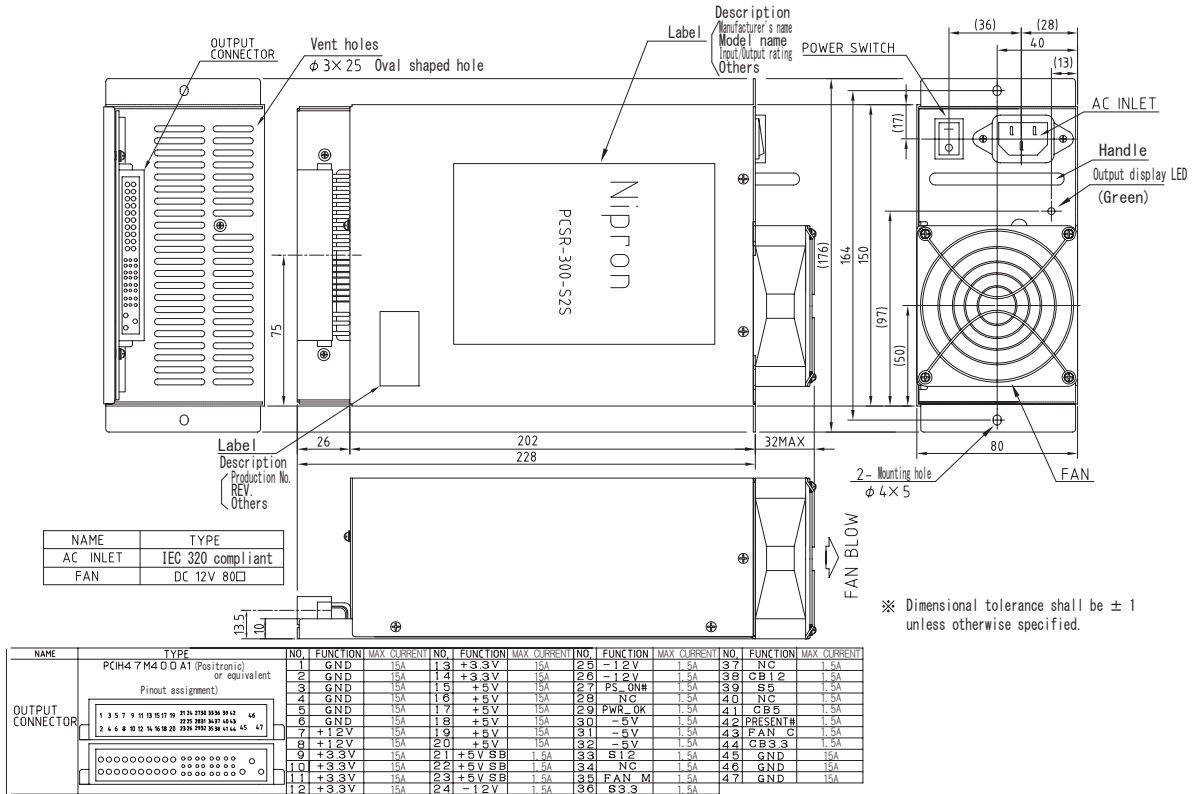

※ Dimensional tolerance shall be ± 1 unless otherwise specified.

| NAME | TYPE | NO. | FUNCTION | MAX. CURRENT | NO. | FUNCTION | MAX. CURRENT | NO. | FUNCTION | MAX. CURRENT | NO. | FUNCTION | MAX. CURRENT |
|------------------|---|-----|----------|--------------|-----|----------|--------------|-----|----------|--------------|-----|----------|--------------|
| OUTPUT CONNECTOR | PCH4 7 M4 0 0 A1 (Postronic) or equivalent Pinout assignment | 1 | GND | 15A | 13 | +3.3V | 15A | 25 | -12V | 1.5A | 37 | NC | 1.5A |
| | | 2 | GND | 15A | 14 | +3.3V | 15A | 26 | -12V | 1.5A | 38 | CB1 2 | 1.5A |
| | | 3 | GND | 15A | 15 | +5V | 15A | 27 | PS_ON | 1.5A | 39 | S5 | 1.5A |
| | | 4 | GND | 15A | 16 | +5V | 15A | 28 | NC | 1.5A | 40 | NC | 1.5A |
| | | 5 | GND | 15A | 17 | +5V | 15A | 29 | PWR_OK | 1.5A | 41 | CB5 | 1.5A |
| | | 6 | GND | 15A | 18 | +5V | 15A | 30 | -5V | 1.5A | 42 | PRESENT | 1.5A |
| | | 7 | +12V | 15A | 19 | +5V | 15A | 31 | -5V | 1.5A | 43 | FAN_C | 1.5A |
| | | 8 | +12V | 15A | 20 | +5V | 15A | 32 | -5V | 1.5A | 44 | CB3 3 | 1.5A |
| | | 9 | +3.3V | 15A | 21 | +5V SB | 1.5A | 33 | S1 2 | 1.5A | 45 | GND | 15A |
| | | 10 | +3.3V | 15A | 22 | +5V SB | 1.5A | 34 | NC | 1.5A | 46 | GND | 15A |
| | | 11 | +3.3V | 15A | 23 | +5V SB | 1.5A | 35 | FAN_M | 1.5A | 47 | GND | 15A |
| | | 12 | +3.3V | 15A | 24 | -12V | 1.5A | 36 | S3 3 | 1.5A | | | |

Optional Components (Sold separately)

| Page | Photo | Model | Category | Description |
|-------|-------|--------|----------------|------------------|
| B-646 | | WH2753 | AC power cable | AC125V 12A [PSE] |

| Other options | | | | | |
|---------------|-----------|--|-------|-----------|--|
| Page | Model | Description | Page | Model | Description |
| B-652 | ACC2637 | Automatic Startup Unit | B-650 | WH5105 | 12V 4-pin connector conversion harness (80mm) |
| B-649 | WH2820 | 20-pin extension harness (600mm) | B-650 | WH5105-02 | 12V 4-pin connector conversion harness (320mm) |
| B-649 | WH2747 | 20-pin extension harness (450mm) | B-647 | WH5055 | AT connector conversion harness |
| B-649 | WH2892-02 | 20-pin extension harness (200mm) | B-647 | ACC5046 | PS_ON switch equipped harness |
| B-651 | WH2812 | PCI-E 6-pin connector conversion harness | B-648 | ACC5077 | PS_ON terminal shorting connector |
| | | | B-648 | WH5073 | PS_ON terminal shorting 20-pin harness |

A. UPDATE

- B-A SELECTION GUIDE
- B-B PRODUCT PAGE GUIDELINE
- B-C NONSTOP POWER SUPPLY
- B-D AC+DC DUAL-INPUT PSU
- B-E GENERAL PURPOSE PC PSU
- B-F GENERAL PURPOSE REDUNDANT PSU
- B-G OPTIONS

- C-A SELECTION GUIDE
- C-B PRODUCT PAGE GUIDELINE
- C-C AC-DC SINGLE OUTPUT NONSTOP PSU
- C-D AC-DC MULTI-OUTPUT NONSTOP PSU
- C-E AC-DC SINGLE OUTPUT POWER SUPPLY
- C-F AC-DC MULTI-OUTPUT POWER SUPPLY
- C-G DC-DC CONVERTER
- C-H OPTIONS

- D. TECHNICAL DICTIONARY
- E. COMPANY PROFILE
- F. BUSINESS MANUAL
- G. INDEX

Characteristics Data PCSR-300-X2V (Examples of actual measurement)

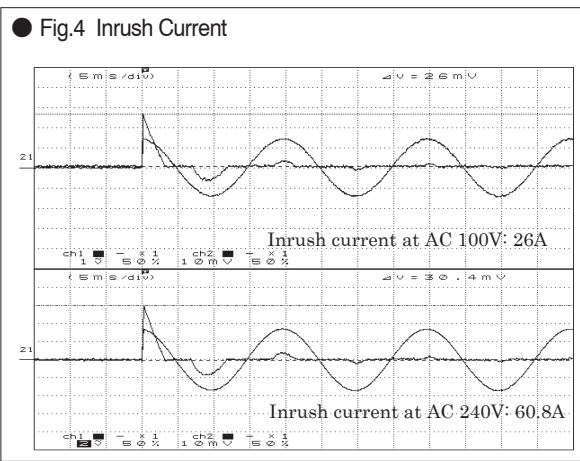
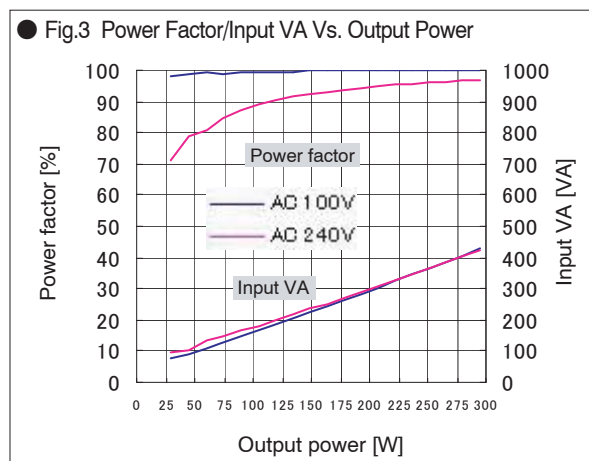
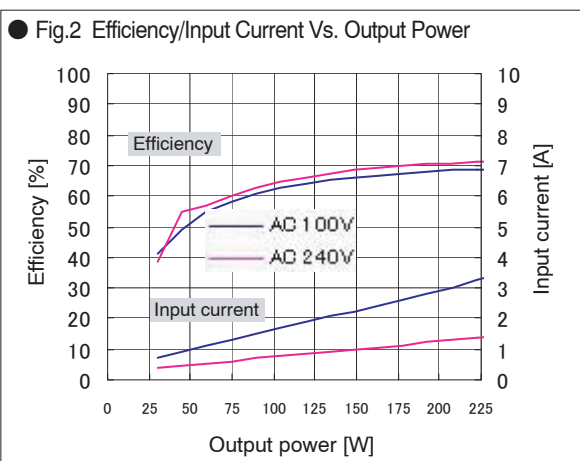
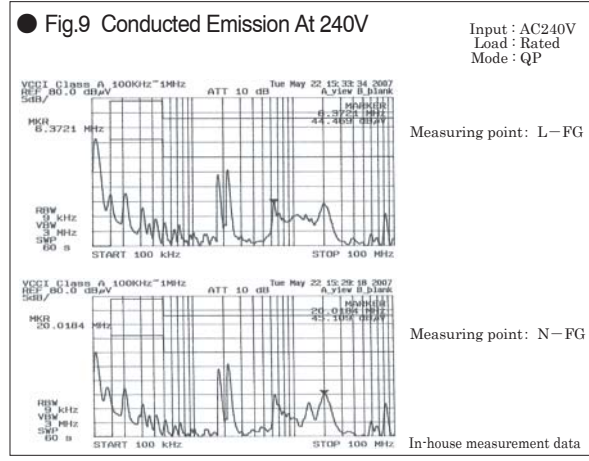
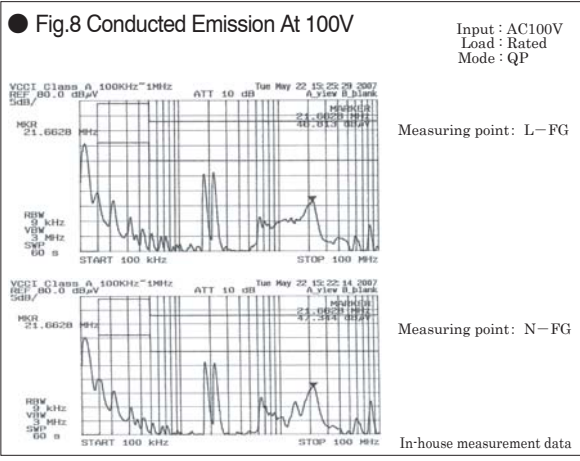
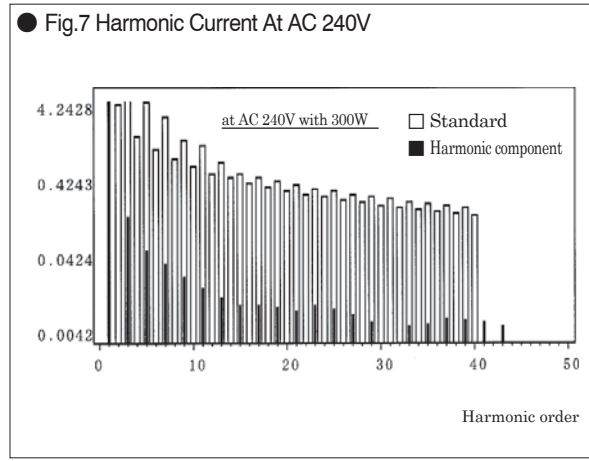
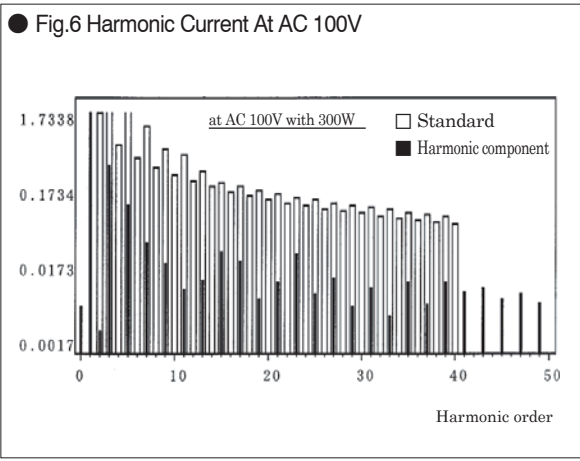
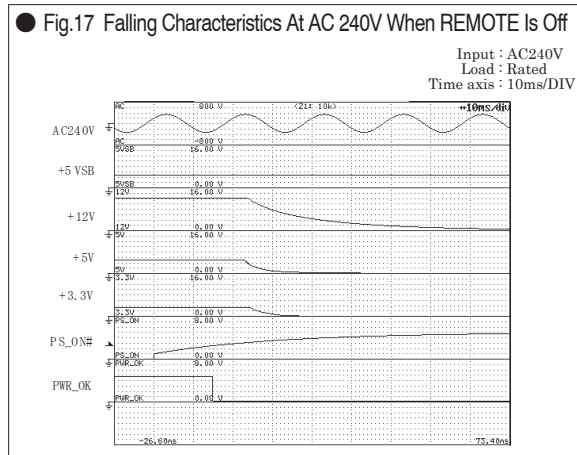
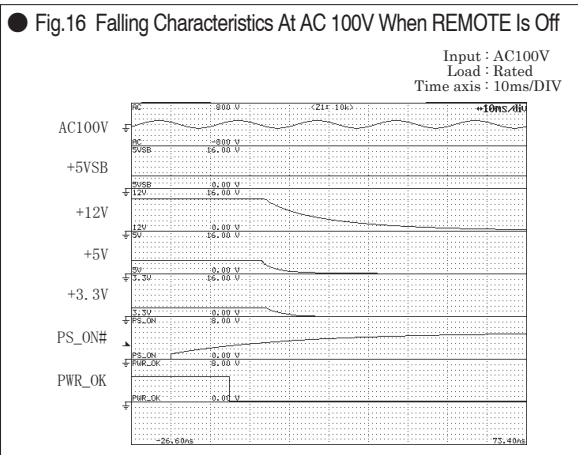
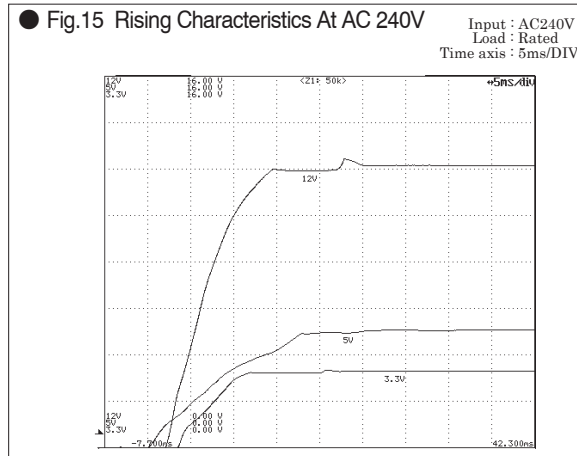
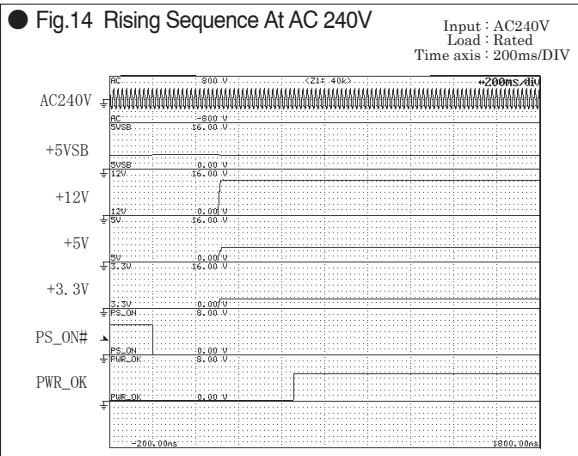
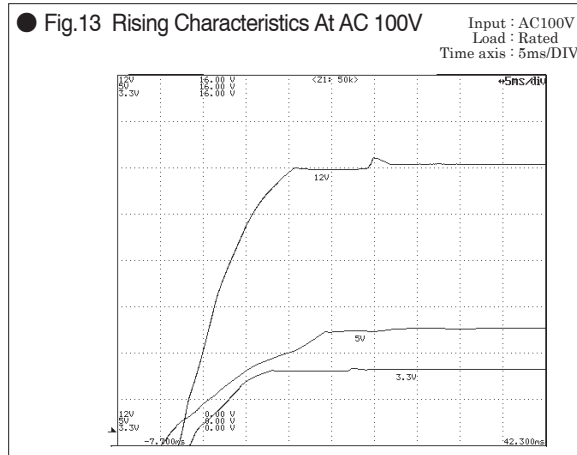
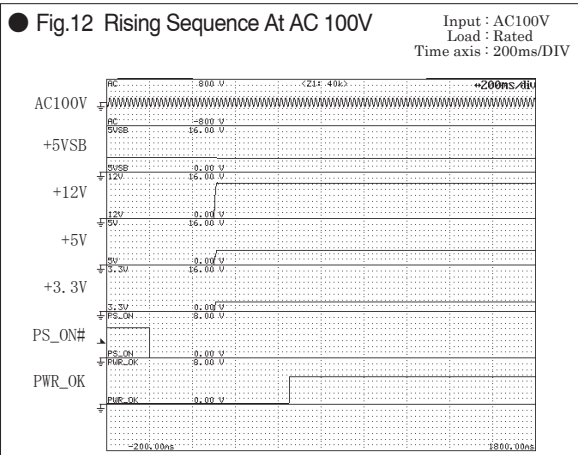
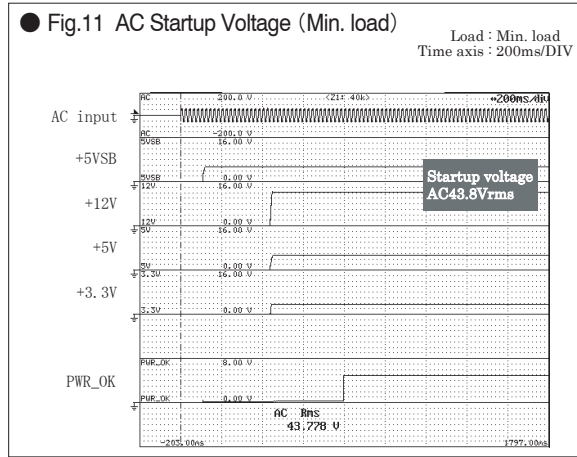
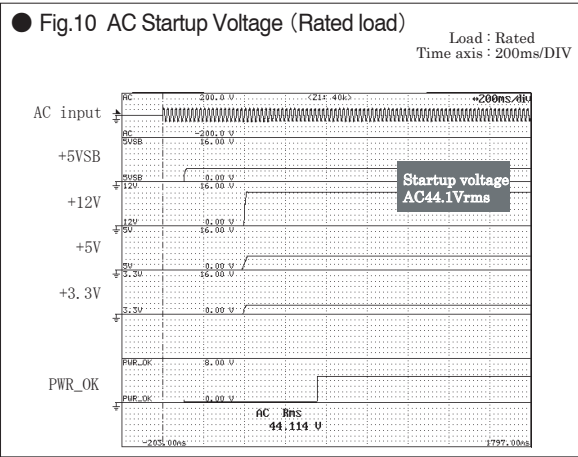

Fig.5 Leakage Current

Input : AC100, 240V
Load : Rated load and Min. load

| | Rated load | Min. load |
|---------|------------|-----------|
| AC 100V | 0.64mA | 0.61mA |
| AC 200V | 1.5mA | 1.5mA |





Computer Power Supply - BRAIN

- B. SELECTION GUIDE
- B. PRODUCT PAGE GUIDELINE
- B. NONSTOP POWER SUPPLY
- B. AC+DC DUAL-INPUT PSU
- B. GENERAL PURPOSE PC PSU
- B. GENERAL PURPOSE REDUNDANT PSU
- B. OPTIONS

Control & Mechanism System Power Supply - LIMBS

- C. SELECTION GUIDE
- C. PRODUCT PAGE GUIDELINE
- C. AC-DC SINGLE OUTPUT NONSTOP PSU
- C. AC-DC MULTI-OUTPUT NONSTOP PSU
- C. AC-DC SINGLE OUTPUT POWER SUPPLY
- C. AC-DC MULTI-OUTPUT POWER SUPPLY
- C. DC-DC CONVERTER
- C. OPTIONS

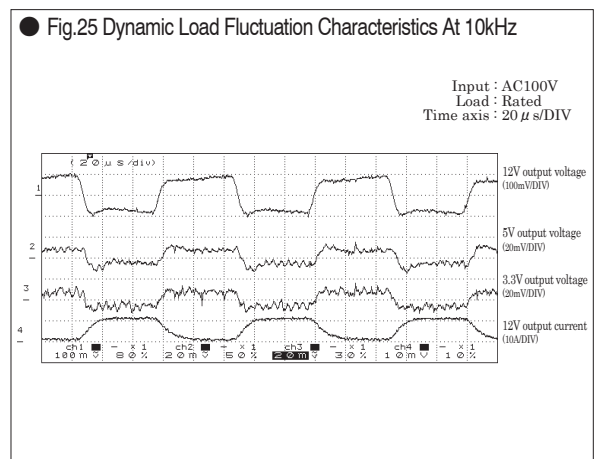
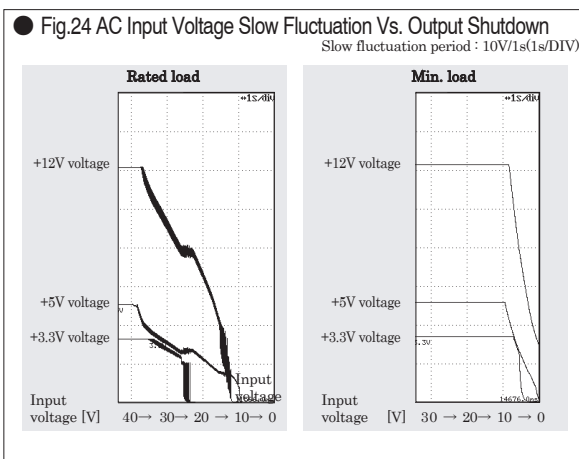
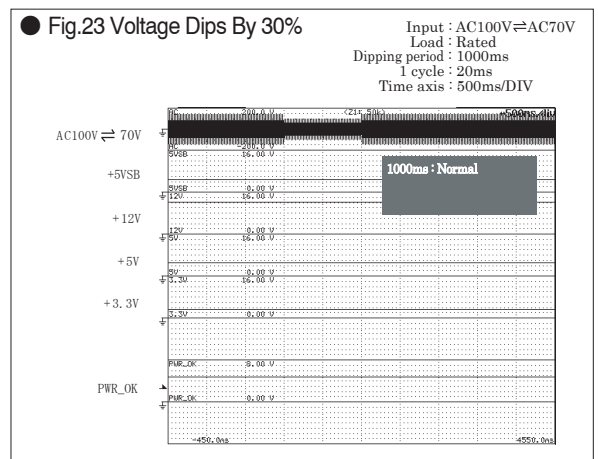
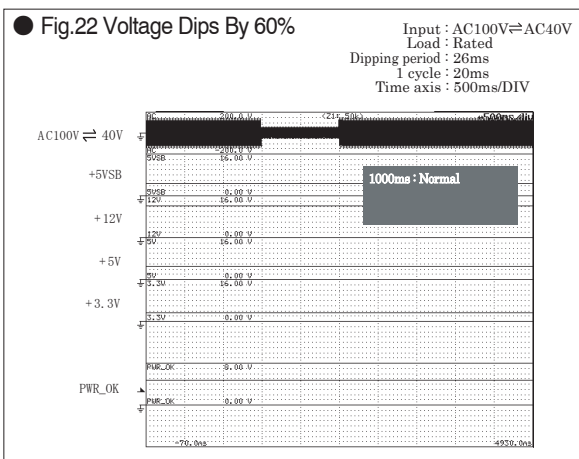
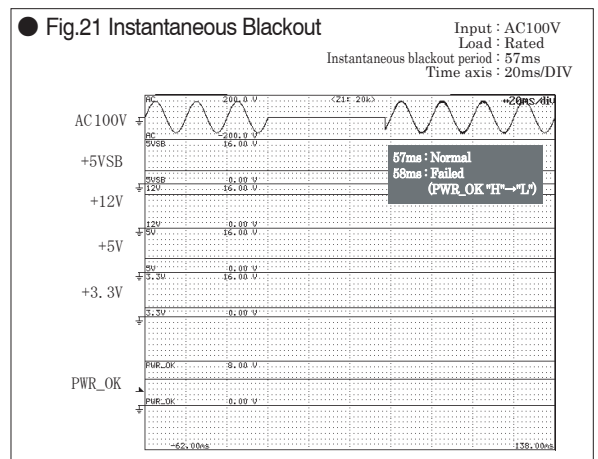
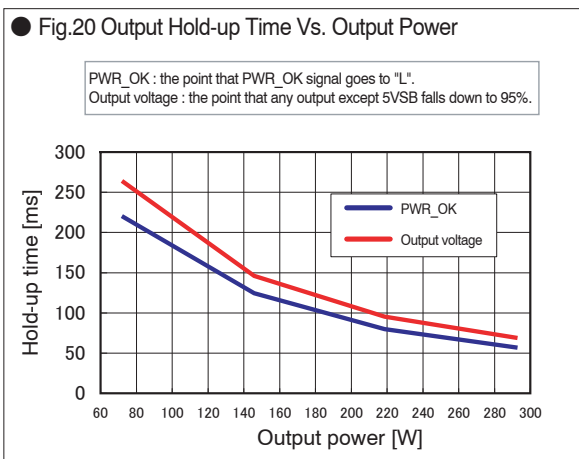
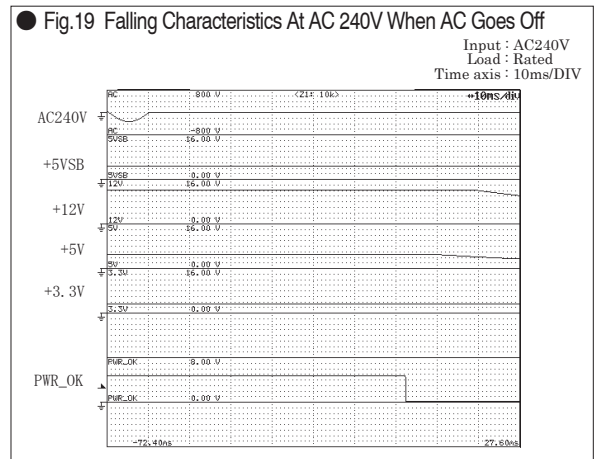
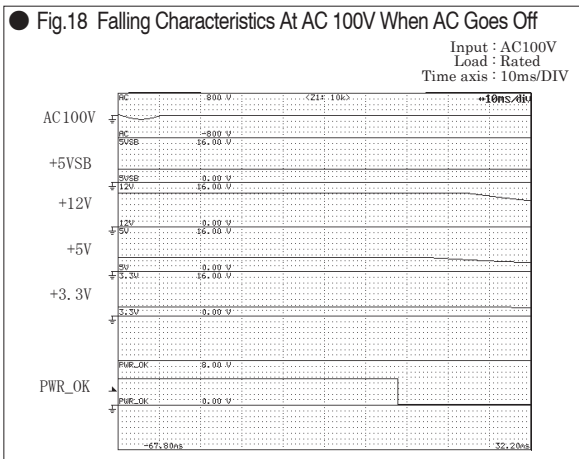

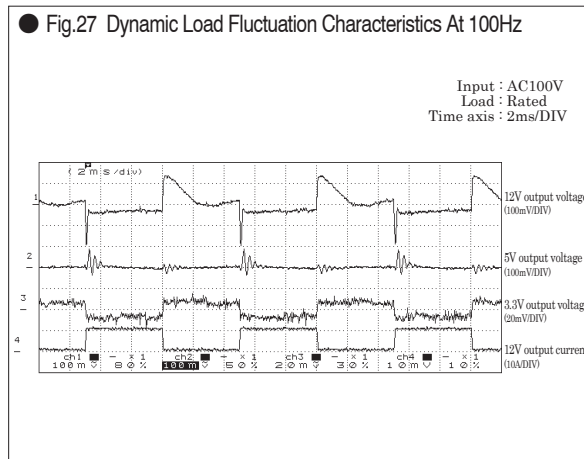
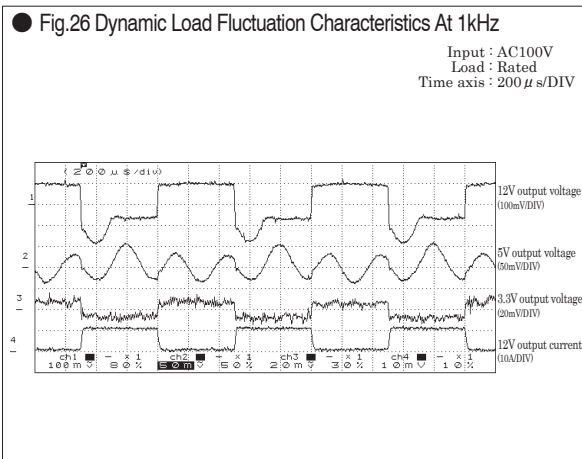

Fig.28 Output Voltage Regulation

| | SP50 | | | SP100 | | | SP150 | | |
|-----------|-----------|------------|-----------|-----------|------------|-----------|-----------|------------|-----------|
| | Min. load | Rated load | Peak load | Min. load | Rated load | Peak load | Min. load | Rated load | Peak load |
| 12V load | 0.1A | 10A | 15A | 0.1A | 10A | 15A | 0.1A | 10A | 15A |
| 5V load | 2A | 20A | 35A | 2A | 20A | 35A | 2A | 20A | 35A |
| 3.3V load | 0A | 15A | 28A | 0A | 15A | 28A | 0A | 15A | 28A |

| AC 入力 | AC 85V | AC 100V | AC 132V | AC 176V | AC 240V | AC 264V |
|-------------------|----------|----------|----------|----------|----------|----------|
| 12V load (min.) | 12.267 V | 12.268 V | 12.267 V | 12.267 V | 12.267 V | 12.268 V |
| 12V load (rated) | 12.129 V | 12.129 V | 12.130 V | 12.128 V | 12.129 V | 12.130 V |
| 12V load (peak) | 12.127 V | 12.127 V | 12.126 V | 12.126 V | 12.126 V | 12.128 V |
| 5V load (min.) | 5.127 V | 5.127 V | 5.127 V | 5.127 V | 5.126 V | 5.126 V |
| 5V load (rated) | 5.079 V | 5.079 V | 5.079 V | 5.078 V | 5.078 V | 5.078 V |
| 5V load (peak) | 5.058 V | 5.058 V | 5.058 V | 5.058 V | 5.058 V | 5.058 V |
| 3.3V load (min.) | 3.353 V | 3.353 V | 3.353 V | 3.353 V | 3.353 V | 3.353 V |
| 3.3V load (rated) | 3.309 V | 3.309 V | 3.309 V | 3.309 V | 3.309 V | 3.309 V |
| 3.3V load (peak) | 3.300 V | 3.300 V | 3.300 V | 3.300 V | 3.300 V | 3.300 V |

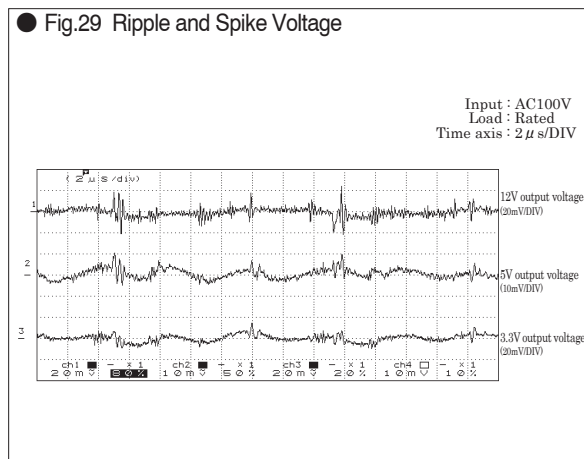

Fig.30 Ambient Temperature Vs. Lifetime Expectancy

■ Electrolytic capacitors (PCSR-300-S2S)

Input : AC100V
Load : Rated

| Temp. of intake air | 20°C | 30°C | 40°C | 50°C |
|--------------------------|------------|------------|-------------|-------------|
| Lifetime expectancy (yr) | approx. 32 | approx. 16 | approx. 8.1 | approx. 4.0 |

※ Lifetime shall be 15 years at longest due to deterioration of sealing plates. UOM: Year

■ FAN

| Ambient temp. of Fan | 40°C | 50°C | 60°C |
|--------------------------|-------------|-------------|-------------|
| Lifetime expectancy (yr) | approx. 7.4 | approx. 6.4 | approx. 4.6 |

UOM: Year

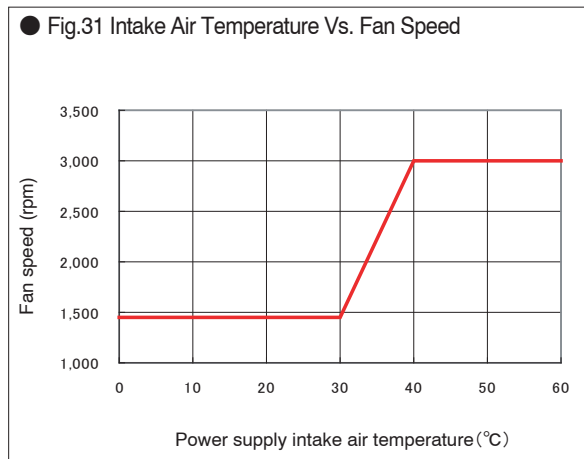

Computer Power Supply - BRAIN

Control & Mechanism System Power Supply - LIMBS

- A. UPDATE
- B. SELECTION GUIDE
 - B-A. PRODUCT PAGE GUIDELINE
 - B-B. NONSTOP POWER SUPPLY
 - B-C. AC+DC DUAL-INPUT PSU
 - B-D. GENERAL PURPOSE PC PSU
 - B-E. GENERAL PURPOSE REDUNDANT PSU
 - B-F. OPTIONS
- C. SELECTION GUIDE
 - C-A. PRODUCT PAGE GUIDELINE
 - C-B. AC/DC SINGLE OUTPUT NONSTOP PSU
 - C-C. AC/DC MULTI-OUTPUT NONSTOP PSU
 - C-D. AC/DC SINGLE OUTPUT POWER SUPPLY
 - C-E. AC/DC MULTI-OUTPUT POWER SUPPLY
 - C-F. DC-DC CONVERTER
 - C-G. OPTIONS
- D. TECHNICAL DICTIONARY
- E. COMPANY PROFILE
- F. BUSINESS MANUAL
- G. INDEX