

Desktop PC Power Supply PCSI-470P Series

High-Power, Silent Power Supply



PCSA-470P-X2S

RoHS Directive

ATX/EPS
 Continuous Max. **340W** Peak Power **470W**

Model	Description	Stock
PCSA-470P-X2S	ATX output (with main 20-pin, 12V 4-pin connector)	Standard stock
PCSA-470P-E2S	EPS output (with main 24-pin, processor (12V 8-pin) connector)	Standard stock

Model Name Coding

PCSA - 470 P - * 2 S

① ② ③ ④ ⑤ ⑥

- Series name
- Output power
- Peak output compliant
- X: ATX output, E: EPS output
- +3.3V output equipped
- Standard

* "PCSA-470P-E2J1" with S-ATA connector is on p.151

Features

- 470W silent power supply
- Specification of PCSA-470P-X2S is ATX output (Main connector 20-pin, 12V connector 4-pin)
- Specification of PCSA-470P-E2S is EPS output (Main connector 24-pin, Processor connector 8-pin)

Introduction of modified products: +12V output enhanced type

Modify product of PCSA-470P-E2S

Increased +12V output to continuous **18A (Peak 24A)**

Model: PCSA-470P-E2P

Output

Output voltage	+3.3V	+5V	+12V	-12V	+5VSB
Max. current / max. power (continuous)	25A Total 30A	30A Total 30A	18A Total 336W	0.9A	2.2A
Peak current / peak power (5 sec max.)	31A Total 40A	40A Total 40A	24A Total 440W	0.9A	3.0A
Min. current	0A	0A	0A	0A	0A

*Min. lot is 50 pcs: Lead time 100days
Please ask for detail

Output connector

Model	Main 20+4pin	Main 24pin	Main 20pin	AT	AUX	12V 4pin	12V 8pin	PCI-E 6pin	PCI-E 6+2pin	HDD	S-ATA	FDD
PCSA-470P-X2S	✓	✓	✓	✓	✓	✓	✓	✓	✓	✓	✓	✓
PCSA-470P-E2S	✓	✓	✓	✓	✓	✓	✓	✓	✓	✓	✓	✓

Refer to "Product Page Guideline" on p.13

Safety standard / Approval	UL	CSA	EN	CE	CCC
Reliability Grade	HFA	FA	HOA	OA	

Function

DC start	RS 232C	USB	TTL	PFC	Silence	5VSB FAN	TSFC FAN	Connection	RoHS
----------	---------	-----	-----	-----	---------	----------	----------	------------	------

Input

AC input	85 - 264V (worldwide range)
----------	-----------------------------

Output

Model: PCSA-470P-X2S

Output voltage	+3.3V	+5V	+12V	-5V	-12V	+5VSB
Max. current / max. power (continuous)	31A Total 36A	36A Total 36A	16.7A Total 331W	0.5A	0.9A	2.2A
Peak current / peak power (5 sec max.)	31A Total 40A	40A Total 40A	20A Total 200W	0.5A	0.9A	3.0A
Min. current	0A	2A	0A	0A	0A	0A

Model: PCSA-470P-E2S

Output voltage	+3.3V	+5V	+12V	-12V	+5VSB
Max. current / max. power (continuous)	31A Total 36A	36A Total 36A	16.7A Total 331W	0.9A	2.2A
Peak current / peak power (5 sec max.)	31A Total 40A	40A Total 40A	20A Total 200W	0.9A	3.0A
Min. current	0A	2A	0A	0A	0A

Dimensions

W×H×D (mm)	150×86×160 (PS/2 +size)
------------	-------------------------

General Specification Condition: at normal temperature and humidity unless otherwise specified

BRAIN
Power
Supply

Desktop PC Power Supply

Non-backup Power Supply

Items		Specification						Measurement conditions, etc.	
AC Input	Rated Voltage	100 - 240 VAC (85* - 264 VAC)						Worldwide range, but up to 253V for harmonic regulation *Refer to Fig.1	
	Input Frequency	50 / 60Hz						47-63Hz	
	Efficiency	68% min. (100 VAC), 72% min. (240 VAC) *Characteristic data: Fig.6						At rated output	
	Power Factor	95% min. (100 VAC), 92% min. (240 VAC) *Characteristic data: Fig.7							
	Inrush Current	50A peak (240 VAC) *Characteristic data: Fig.8						Input reclosing interval shall be 10 sec min. at rated load. The inrush current into X-capacitor of input noise filter is not specified unless its period is more than 100µs.	
Input VA	Operation	500VA typ. (at rated load), 700VA typ. (at peak power) *Characteristic data: Fig.7							
	Standby	30VA typ. (100 VAC), 60VA typ. (240 VAC) 9VA typ. (100 VAC), 47VA typ. (240 VAC)						PS_ON# signal 'H' or 'OPEN' at rated load of +5VSB PS_ON# signal 'H' or 'OPEN' at no load of +5VSB	
Output	Rated Voltage	+3.3V	+5V	+12	-5V*	-12V	+5VSB	*-5V is only available for PCSA-470P-X2S.	
	Rated Current	15A	20A	14A	0.5A	0.9A	2.2A		
	Max. Current / Power	31A	36A	16.7A	0.5A	0.9A	2.2A	Max. output power: 342W Peak output power: 468W (PCSA-470P-X2S) 466W (PCSA-470P-E2S)	
		36A max.		16.7A max.		0.9A max.			
	Peak Current / Power	331W max.						Time: 5 sec or less Duty ratio of repetitive load: 10% or less *Refer to Fig.2: Duty ratio below *Refer to Fig.4 and 5: Output power distribution *Refer to Fig.1 and 3: Derating	
		31A	40A	20A	0.5A	0.9A	3.0A		
		40A max.		200W max.					
	Min. Current	0A*	2A*	0A	0A	0A	0A	*Or total power of +3.3V, +5V is 10W min.	
	Total Voltage Accuracy 1 (%)	PCSA-470P-X2S	+5/-3 max.	±5 max.	±5 max.	±6 max.	±6 max.	±5 max.	*Refer to Fig.4
		PCSA-470P-E2S	+5/-3 max.	±5 max.	±5 max.	-	+9/-5 max.	+5/-4 max.	Accuracy with humidity, temperature, time drift for input/load change within power in range
Total Voltage Accuracy 2 (%)	PCSA-470P-E2S	+5/-3 max.	+5/-4 max.	+5/-4 max.	-	+9/-5 max.	+5/-4 max.	*Refer to Fig.5 Accuracy with humidity, temperature, time drift for input/load change within power in range	
Max. Ripple Voltage (mVp-p)	50 max.		50 max.	120 max.	50 max.	120 max.	50 max.	Measured on a test board connected with a 47µF capacitor. The test board shall be away from load wire and within 150mm from output terminals. *Characteristic data: Fig.19	
Max. Spike Voltage (mVp-p)	100 max.		100 max.	170 max.	100 max.	170 max.	100 max.		
Protection	Overcurrent Protection	OCP Point (A)	32 min.	-	-	-	-	-	At min. output power, except measured output
			-	43 min.	21 min.	0.55 min.	0.95 min.	3.1 min.	At max. output power, except measured output with no load of +3.3V
		Method	Hold down current limiting→ +3.3V, +5V, +12V, -5V, -12V output shutdown			Fold back current limiting		Blocking oscillation	All outputs shutdown when +5VSB is shorted. (automatic recovery)
	Recovery	Reclosing of input (10 sec min. interval) or PS_ON# signal 'H' to 'L'			Automatic recovery				
	Overvoltage Protection	OVP Point (V)	3.7 - 4.3	5.7 - 7.0	13.8 - 15.6	-	-	-	
		Method	+3.3V, +5V, +12V, -5V, -12V output shutdown			-	-	-	
Recovery		Reclosing of input (10 sec min. interval) or PS_ON# signal 'H' to 'L'			-	-	-		
Overpower Protection	OPP Point (V)	Total output power 340W min. / Shutdown retardation time 6 sec min.						-	
	Method	+3.3V, +5V, +12V, -5V, -12V output shutdown (Retardation shutdown method)						-	
	Recovery	Reclosing of AC input (10 sec min. interval) or PS_ON# signal 'H' to 'L'							
Fan Stop Protection	At fan motor stops by failure, +3.3V, +5V, +12V, -5V, -12V output shutdown						Reclosing of AC input (10 sec min. interval) or PS_ON# signal 'H' to 'L'		
Environment	Operating Temp. / Humidity	0 to 60°C* / 20 to 90%						*Refer to Fig.3 No condensation	
	Storage Temp. / Humidity	-20 to 70°C/10 to 95%						No condensation	
	Vibration	Displacement amplitude: 0.075mm (10-55Hz), Sweep cycles: 10, Test duration: 45 minutes each axis						JIS-C-0040-1999, at no operation	
	Mechanical Shock	Lift one bottom edge up to 50mm and let it fall. Number of bumps: 3 each of 4 edges						JIS-C-0043-1995, at no operation	
Insulation	Dielectric Strength	AC input - DC output/FG: 1500 VAC for 1 minute						Cut-off current: 20mA max.	
	Insulation Resistance	AC input - DC output/FG: 50MΩ min.						At 500 VDC	
		DC output - FG: 50MΩ min.						Normal temp. / humidity	
	Leakage Current	0.5mA max. (100 VAC) / 1mA max. (200 VAC) *Characteristic data: Fig.9						YEW. TYPE3226 (1kΩ) or equivalent	
EMC	Line Noise Immunity	± 2000V (pulse width: 100/1000ns, repetitive cycle: 30-100Hz, normal/common modes with pos./neg. polarity for 1 minute)						Measured by INS-410 No fluctuation of DC output or malfunction	
	Electrostatic Discharge	EN61000-4-2 compliant							
	Radiated, Radio-Frequency EM Field	EN61000-4-3 compliant							
	Fast Transient Burst	EN61000-4-4 compliant							
	Lightning Surge	EN61000-4-5 compliant							
	RF Conducted Immunity	EN61000-4-6 compliant							
	Magnetic Field Immunity	EN61000-4-8 compliant							
	Voltage Dip / Regulation	EN61000-4-11 compliant							
	Conducted Emission	VCCI-B, FCC-B, EN55022-B CISPR22-B compliant *Characteristic data: Fig.10 and 11						Measured by single unit	
	Harmonic Current Regulation	IEC61000-3-2 Class A compliant						At input voltage range of 90 - 253V	
Others	Safety Standard	UL60950, CSA C22.2 No.60950 (c-UL), EN60950-1							
	Cooling System	Forced air cooling: thermal-sensing variable speed fan embedded						Fan speed changes by temperature and load.	
	Output Grounding	Capacitor grounding							
	Output Hold-up Time	PWR_OK holds up 17ms min. after AC failure. *Characteristic data: Fig.16						At rated output	
	Reliability Grade	HOA						Follow our standard	
	MTBF	100,000 H min.						Based on EIAJ RCR-9102	
	Weight	2.6 kg typ.							
Warranty	1 years after delivery. If any faults belong to us, the defective unit shall be repaired or replaced at our cost.						Except for errors caused by operation not listed		

General Specification Condition: at normal temperature and humidity unless otherwise specified

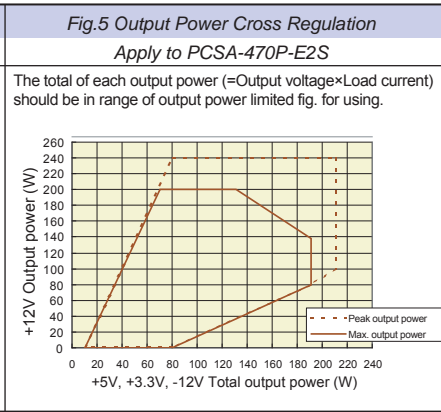
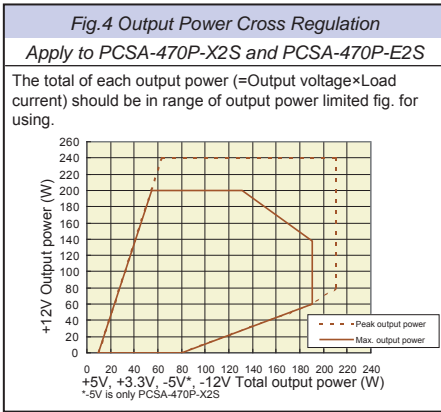
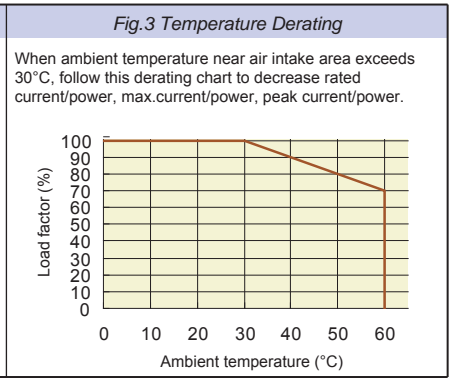
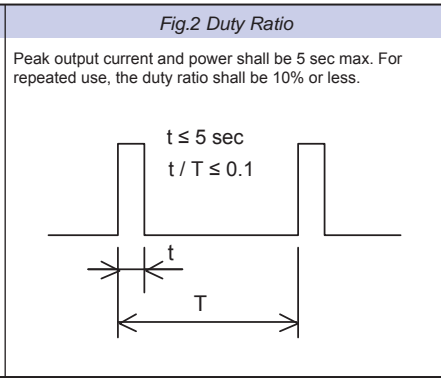
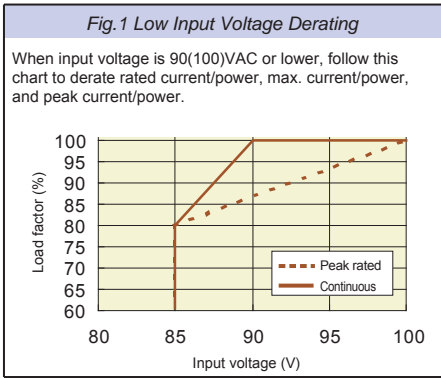

Signal Input / Output Specification Condition: at normal temperature and humidity unless otherwise specified

Refer to [] only for PCSA-470P-E2S.

Items	Specification	Note	
Input Signal	Output ON / OFF Control Signal (PS_ON#)	+3.3V, +5V, +12V, -5V, and -12V [+3.3V, +5V, +12V, and -12V] outputs are delivered with 'L' input. +3.3V, +5V, +12V, -5V, and -12V [+3.3V, +5V, +12V, and -12V] outputs shutdown with 'H' or 'OPEN' input and, protection circuit is activated to reset locked latch circuit at output shutdown status.	Signal input between the pin 14 [16] of P1 connector and COM pin
	+3.3V SENSE	The input terminal to detect the voltage of +3.3V output; by connecting to the load terminal, only the line drop of the + side of the output cable is compensated.	The pin 11 [13] of P1 connector
	Fan Control Signal (FAN C)	Fan motor spin the most at normal input voltage over 10.5V±5%. Speed control inside the power supply comes first when input voltage is lower than that or open.	The pin 2 of P12 [P13] connector
Output Signal	Normal Output Signal (PWR_OK)	'H' signal is delivered when the +5V output is normal (detection delay time: 200 - 500ms).	The pin 8 of P1 connector
	Fan Monitor Signal (FAN M)	Two cycle pulses per one rotation of the fan motor are delivered (open collector output). Duty ratio of the pulse shall be 0.5 typ. (Interval between the signals becomes longer at low speed and shorter at high speed.) The signal remains 'L' or 'OPEN' when the fan stops caused by any failure or malfunction.	The pin 1 of P12 [P13] connector

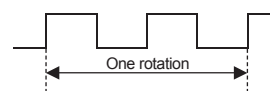

Signal Circuit

Input Signal Circuit	(PS_ON#)	(FAN C)
Output Signal Circuit	(PWR_OK)	(FAN M)

Sequence Diagram

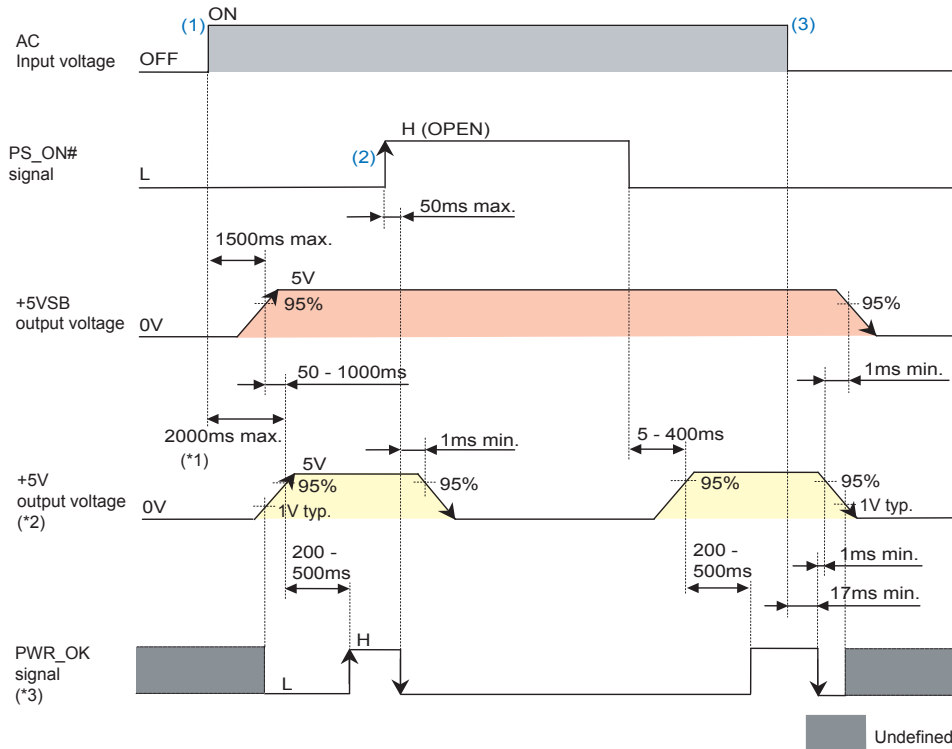



(*1) Reclosing interval after shutting down the input: more than 10 sec min.
 (*2) All other outputs except for +5V shall follow this timing and the rising time difference from +5V shall be 50ms or less. In addition, output voltage level of +5V and +12V at rising shall be more than the voltage level of +3.3V. The difference of output voltage level of +5V and +3.3V should be less than 2.25V. Each output voltage at the time of trailing rank or level differences are unregulated.
 (*3) A rise and a fall time of PWR_OK# signal shall be less than 100µs at the time of the capacitive load is not connected to signal output.

(1) All outputs start up by being supplied AC input under the condition of PS_ON# 'L'. PWR_OK 'H' is delivered at 200 - 500ms after +5V output has risen.
 (2) At PS_ON# 'H (OPEN)' input, outputs except for +5VSB shut down.
 (3) PWR_OK turns to 'L' after 17ms or longer from blackout. 1ms later than this event, the +5V output shuts down.

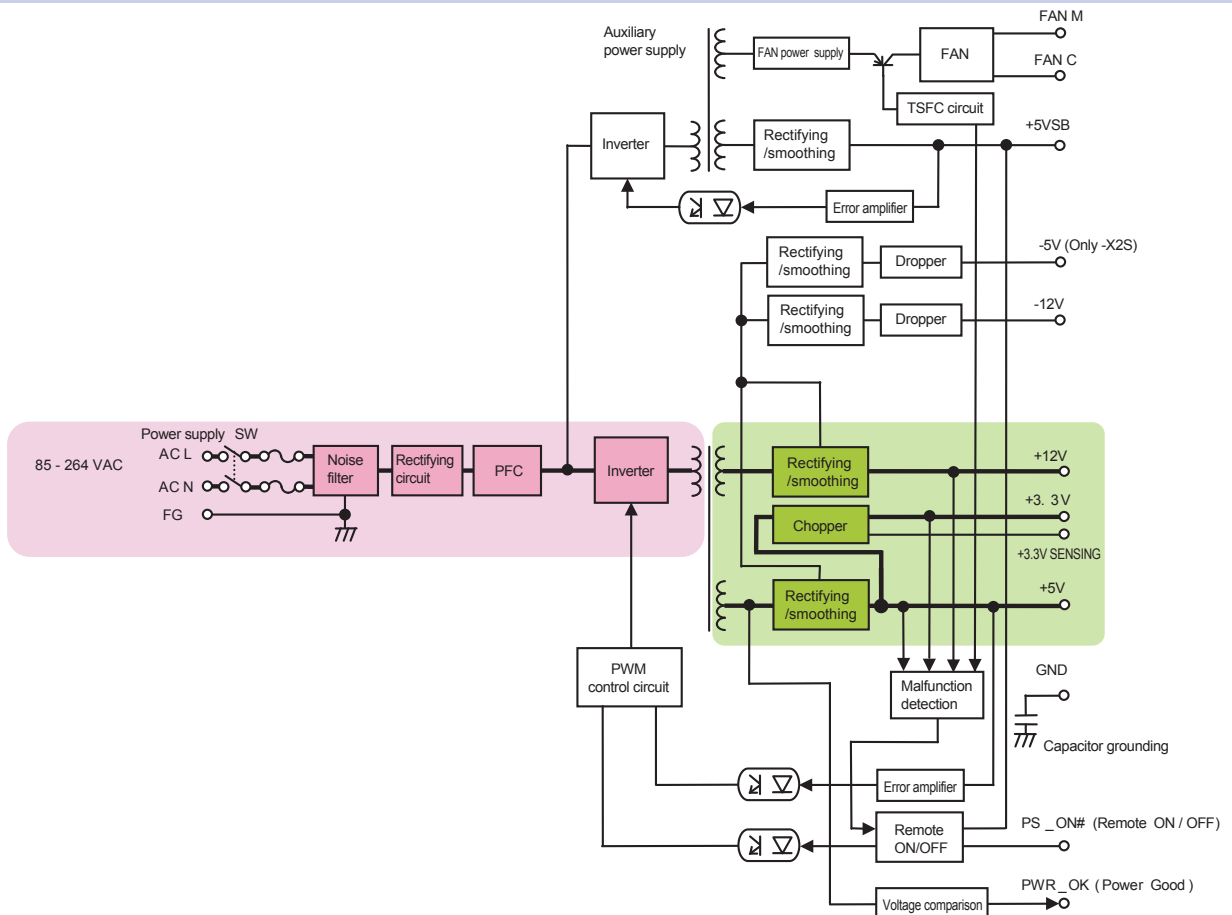
Block Diagram



Optional Components Sold Separately

Cable			
Picture	Model	Type	Description
	WH2753	AC power cord	125 VAC 12A [PSE]
	WH2753-02	AC power cord	125 VAC 12A (tracking resistance type) [PSE]

Other Optional Components			
Model	Description	Model	Description
ACC2637	Automatic startup unit	WH5105	12V 4-pin connector conversion harness (80mm)
WH2820	20-pin extension harness (600mm)	WH5105-02	12V 4-pin connector conversion harness (320mm)
WH2747	20-pin extension harness (450mm)	WH5055	AT connector conversion harness
WH2892-02	20-pin extension harness (200mm)	ACC5046	Harness with PS_ON switch
WH2812	PCI-E 6-pin connector conversion harness	ACC5077	PS_ON terminal short connector
		WH5073	PS_ON terminal short 20-pin harness

Internal Structure

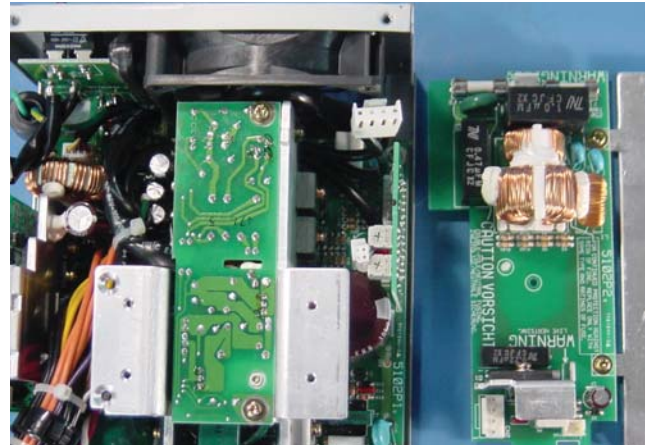
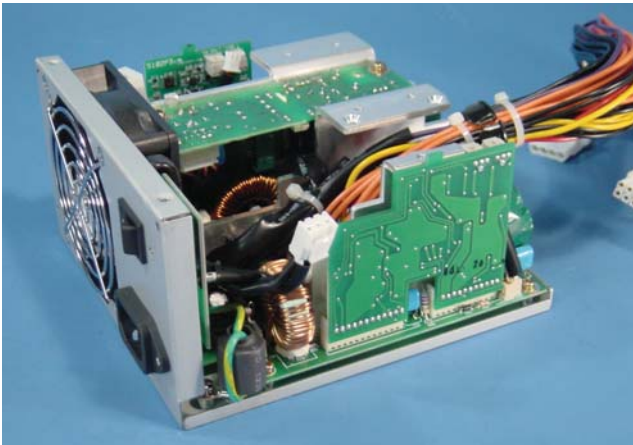

Characteristics Data PCSA-470P-X2S (Examples of actual measurement)

● Fig.6 Efficiency / Input Current vs. Output Power

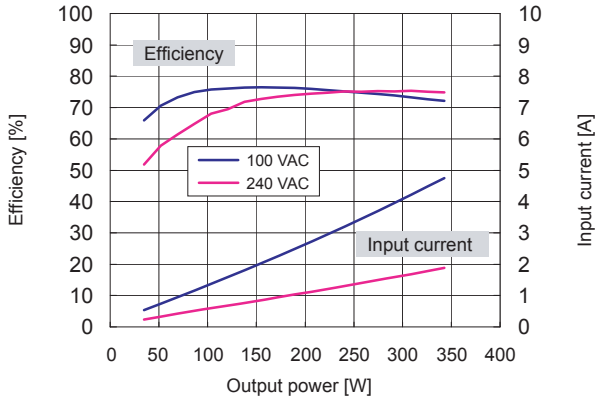

● Fig.7 Power Factor / Input VA vs. Output Power

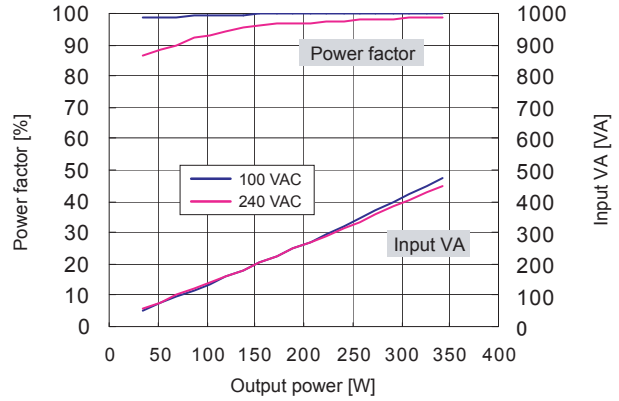

● Fig.8 Inrush Current

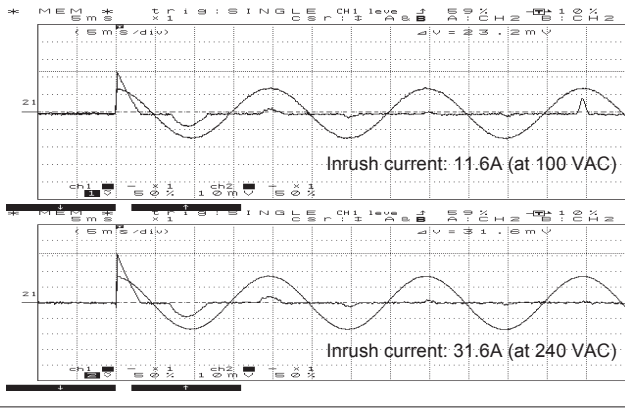

● Fig.9 Leakage Current

Input: 100 / 240 VAC
Load: Rated and min. load

	Rated load	Min. load
100 VAC	0.28mA	0.25mA
240 VAC	0.75mA	0.75mA

● Fig.10 Conducted Emission at 100 VAC

Input: 100 VAC
Load: Rated
Mode: QP

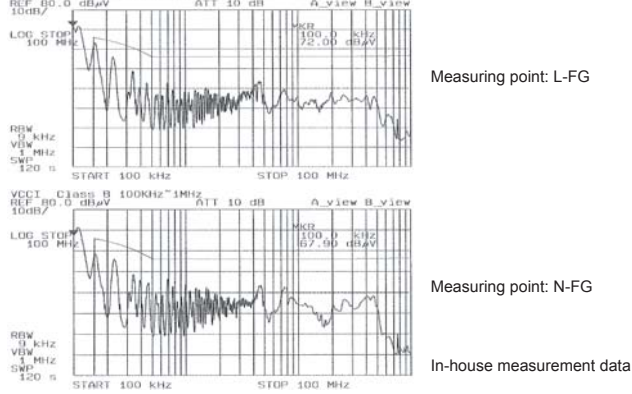

● Fig.11 Conducted Emission at 240 VAC

Input: 240 VAC
Load: Rated
Mode: QP

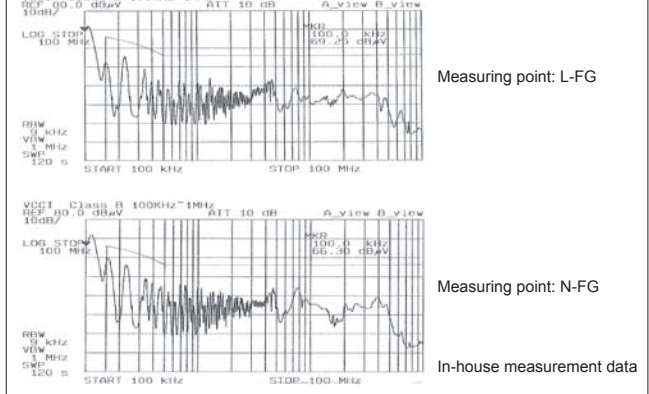

● Fig.12 Rising Characteristics at 100 VAC

Input: 100 VAC
Load: Rated
Time axis: 5ms/DIV

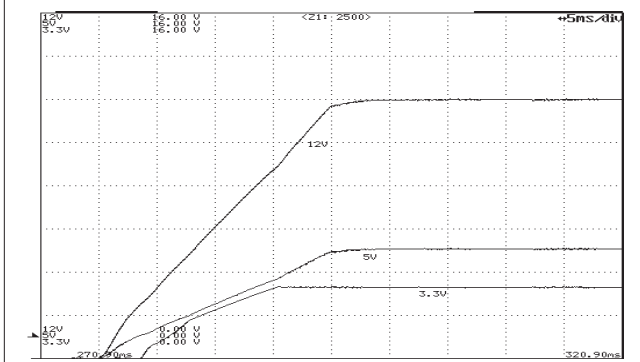

● Fig.13 Falling Characteristics at 100 VAC when REMOTE goes Off

Input: 100 VAC
Load: Rated
Time axis: 10ms/DIV

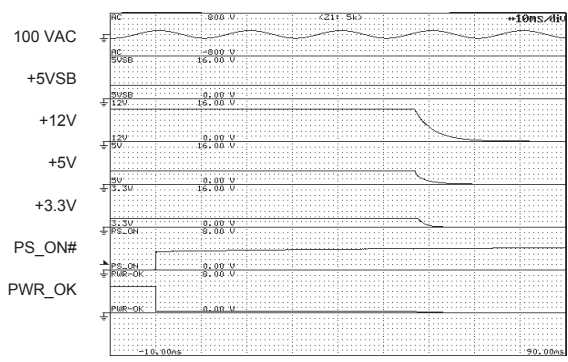

Characteristics Data PCSA-470P-X2S (Examples of actual measurement)

● Fig.14 Rising Characteristics at 240 VAC

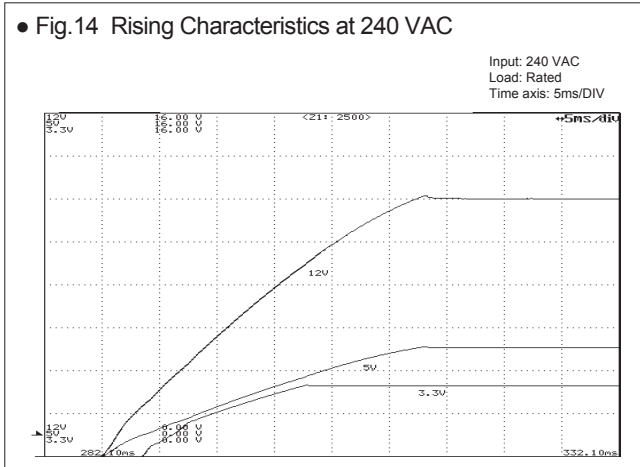

● Fig.15 Falling Characteristics at 240 VAC when REMOTE goes Off

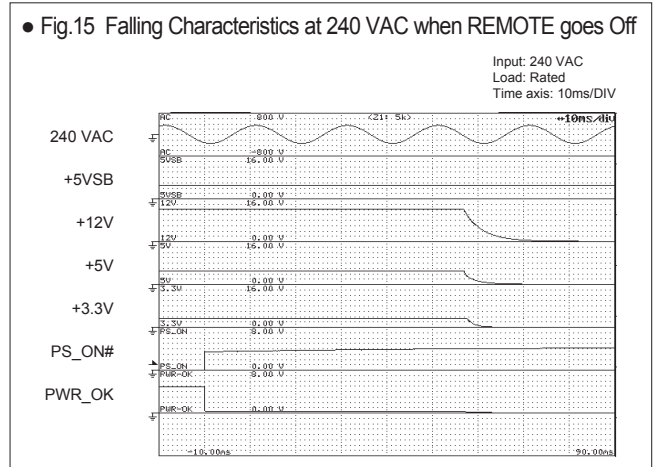

● Fig.16 Output Hold-up Time vs. Output Power

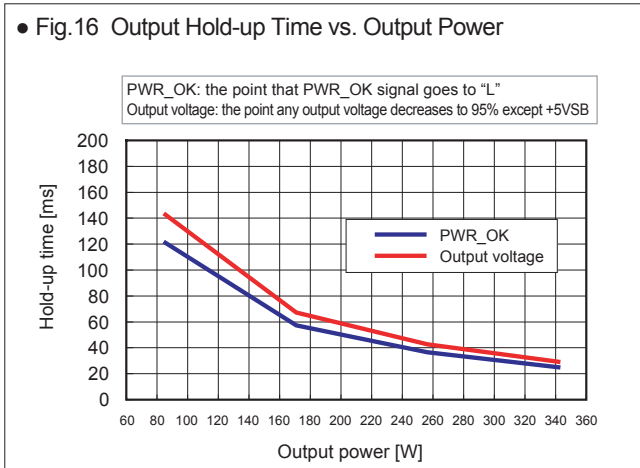

● Fig.17 Dynamic Load Fluctuation Characteristics at 1kHz

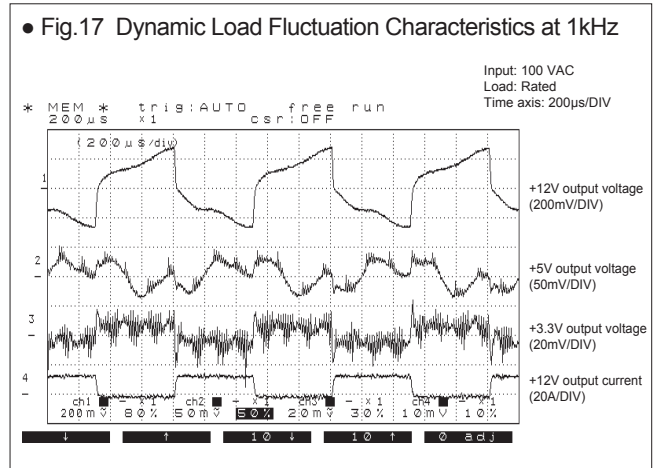

● Fig.18 Output Voltage Regulation

Output	AC input voltage					
	85 VAC	100 VAC	132 VAC	176 VAC	240 VAC	264 VAC
+12V output (min. load)	12.186 V	12.192 V	12.193 V	12.193 V	12.194 V	12.194 V
+12V output (rated load)	12.047 V	12.042 V	12.039 V	12.037 V	12.037 V	12.037 V
+12V output (peak load)	11.996 V	11.992 V	11.988 V	11.985 V	11.985 V	11.984 V
+5V output (min. load)	5.108 V	5.105 V	5.105 V	5.105 V	5.105 V	5.105 V
+5V output (rated load)	5.037 V	5.038 V	5.039 V	5.039 V	5.039 V	5.039 V
+5V output (peak load)	4.972 V	4.973 V	4.974 V	4.975 V	4.975 V	4.975 V
+3.3V output (min. load)	3.352 V	3.352 V	3.352 V	3.352 V	3.352 V	3.352 V
+3.3V output (rated load)	3.282 V	3.283 V	3.283 V	3.283 V	3.283 V	3.283 V
+3.3V output (peak load)	3.242 V	3.242 V	3.242 V	3.242 V	3.242 V	3.242 V

● Fig.19 Ripple and Spike Voltage

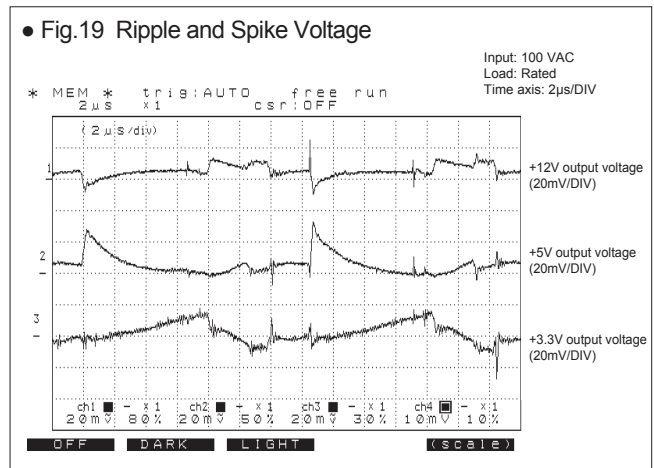

● Fig.20 Ambient Temperature vs. Expected Service Life

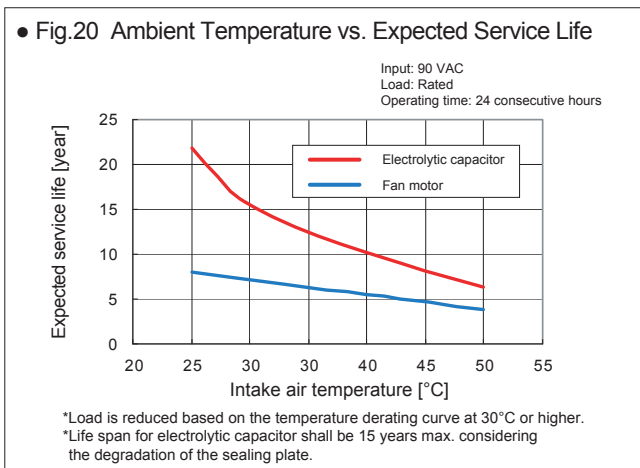

● Fig.21 Over Current Protection (V-I Characteristic)

