

# Desktop PC Power Supply aNSP3-250P Series

Low Cost Nonstop Power Supply with Specialized Functions



aNSP3-250P-S20

**RoHS  
Directive**

<b>ATX</b>	
<b>NSP</b> (nonstop power supply)	
Continuous Max. <b>200W</b>	Peak Power <b>250W</b>

Model	Description	Stock
aNSP3-250P-S20	20-pin main connector	Standard stock
aNSP3-250P-S21	24-pin main and S-ATA connector	Standard stock

■ Model Name Coding

**aNSP3 - 250 P - S 2 \***

①	②	③	④	⑤	⑥
---	---	---	---	---	---

1. Series name	4. Standard
2. Output power	5. DC input voltage (battery voltage) 24V type
3. Peak output compliant	6. Modification code

## Features

- With backup function, it protects your PC from blackout
- With specialized functions and joint components, this unit has achieved low cost.
- Double-sided through holes suitable for industrial use and long life expectancy fan\* are used.  
\*25°C / 70000H, ball-bearing
- 250W peak output, 12V connector embedded
- In order to comply with the harmonic current regulation, choke coils can be added optionally.

This unit does not have a PFC circuit !

This unit is not IEC-61000 compliant !

Be aware that AC input needs shifting to operate either a 100V system or a 200V system with a front switch

Note: Be aware that battery packages that can be used for aNSP3-250P-S21 are different from those of aNSP3-250P-S20

## Batteries for aNSP3-250P-S21

Model	Battery	Type	Page
BS11A-P24/2.3L	Lead	5-inch bay fixed type	P.402
RBS02A-P24/2.3L	Lead	5-inch bay removable type	P.404
BS12A-P24/5.0L	Lead	5-inch bay 2-unit fixed type	P.405

Note: If a dedicated battery package for aNSP3-250P-S20 is needed, consult with us

## Dimensions

W×H×D (mm)	150×86×140 (PS/2 size)
------------	------------------------

Refer to "Product Page Guideline" on p.13

Safety standard / Approval	UL	CSA	EN	CE	CCC
Reliability Grade	HFA	FA	HOA	OA	

## Function



## Automatic shutdown compliant OS



## Input

AC input	90 - 132V, 180 - 264V (with a switch)
DC input	24V (dedicated battery package*)

\*Battery package is optional (sold separately)

## Output

Refer to [ ] only for aNSP3-250-S21. No -5V output available.

Output voltage	+3.3V	+5V	+12V	-5V [-]	-12V	+5VSB
Max. current/ max. power (continuous)	14A Total 125W	21A Total 185W	10A Total 203.6W [202.1W]	0.3A [-]	0.8A	1.5A
Peak current / peak power (5 sec max.)	20A Total 155W	25A Total 230W	13A Total 251.1W [Total 249.6W]	0.3A [-]	0.8A	2.0A
Min. current	0A	2A	0A	0A [-]	0A	0A

## Output connector

### aNSP3-250P-S20

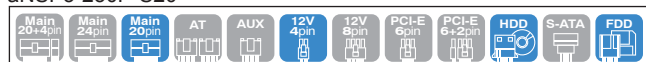

### aNSP3-250P-S21

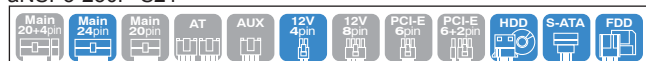

# General Specification Condition: at normal temperature and humidity unless otherwise specified

Refer to [ ] only for aNSP3-250-S21. No -5V output available.

Items		Specification						Measurement conditions, etc.	
AC Input	Rated Voltage	100 / 240 VAC (90 - 132 VAC / 180 - 264 VAC)						Shifting with a switch 100V/200V	
	Input Frequency	50 / 60Hz						47 - 63Hz	
	Efficiency	70% typ. *Characteristic data: Fig.3						At rated input/output with fully-charged battery	
	Power Factor	*Characteristic data: Fig.4							
DC Input	Inrush Current	50A peak (100 VAC), 100A peak (240 VAC) *Characteristic data: Fig.5						At rated input/output at cold start (25°C)	
	Input VA	450VA max. *Characteristic data: Fig.4						At fully-charged battery	
Output	Rated Voltage	24 VDC (corresponds to dedicated battery package)						No battery startup	
	Battery Discharge Cut-off Voltage	18V typ. (shutdown of battery circuit)							
Output	Efficiency (at Battery Operation)	70% typ.						At rated input/output	
	Rated Voltage	+3.3V	+5V	+12V	-5V [-]	-12V	+5VSB		
	Rated Current	9.4A	14A	7A	0.3A [-]	0.8A	1.5A		
	Max. Current / Power	14A	21A	10A	0.3A [-]	0.8A	1.5A	Max. output power: 203.6W [202.1W] *Refer to Fig.1	
		125W max.							
	Peak Current / Power	185W max.						Peak output power: 251.1W [249.6W], Time: 5 sec or less, The interval between peak loads shall be at least 3 minutes. *Refer to Fig.1	
		20A	25A	13A	0.3A [-]	0.8A	2.0A		
	Min. Current	155W / 35A max.							
		230W max.							
	Total Voltage Accuracy (%)	±4 max.	±4 max.	±10 max.	±5 max. [-]	±5 max.	±5 max.	Total accuracy of temperature, input, and load fluctuations	
Max. Ripple Voltage (mVp-p)	50 max.	50 max.	150 max.	50 max. [-]	100 max.	50 max.	Two wires are coming out from the output connector and connected into one at the edge. 47µF electrolytic capacitor is placed on it and it is measured. *Characteristic data: Fig.16		
Max. Spike Voltage (mVp-p)	100 max.	100 max.	200 max.	100 max. [-]	200 max.	100 max.			
Protection	Overcurrent Protection	OCP Point (A)	21 min.	26 min.	14 min.	0.33 min. [-]	0.84 min.	2.1 min.	When measuring +5V, only +12V output is 6A; other outputs have rated current. When measuring +12V, only +5V output is 10A; other output have rated current. For other outputs, all outputs except for the output being measured have rated current.
	Recovery (Overcurrent)	Method	All outputs except for +5VSB shutdown All outputs shutdown at battery operation			Fold back current limiting		All outputs shutdown	
		At AC Operation	Reclosing AC input, or switching PS_ON# signal from 'H' to 'L'			Automatic recovery			
	Overvoltage Protection	OVP point (V)	3.8 - 4.8	5.6 - 7.0	13.4 - 15.6	-	-	-	
Method		All outputs except for +5VSB shutdown All outputs shutdown at battery operation			-	-	-		
Recovery (Overvoltage)	At AC Operation	Reclosing AC input, or switching PS_ON# signal from 'H' to 'L'			-	-	-		
	At Battery Operation	Reclosing AC input			-	-	-		
Charge	Charge Voltage	27.3V typ. (at 25°C, with no load)						Corresponds to dedicated battery package	
	Charge Current	0.5±0.2A (with 24V battery voltage)							
Environment	Operating Temp. / Humidity	0 to 60°C* / 10 to 90%						*Refer to Fig.2 No condensation	
	Storage Temp. / Humidity	-25 to 70°C / 10 to 95%						No condensation	
	Vibration	Displacement amplitude: 0.075mm (10-55Hz), Sweep cycles: 10, Test duration: 45 minutes each axis						JIS-C-0040-1999, at no operation	
Insulation	Mechanical Shock	Lift one bottom edge up to 50mm and let it fall. Number of bumps: 3 each of 4 edges						JIS-C-0043-1995	
	Dielectric Strength	AC input - DC output/FG/DC input: 1500 VAC for 1 minute							
	Insulation Resistance	AC input - DC output/FG/DC input: 50MΩ min.						At 500 VDC	
	Leakage Current	0.5mA max. (100 VAC) / 1mA max. (240 VAC) *Characteristic data: Fig.6						YEW. TYPE3226 (1kΩ) or equivalent	
EMC	Line Noise Immunity	± 2000V (pulse width: 100/1000ns, repetitive cycle: 10-50ms)						No fluctuation of DC output or malfunction	
	Electrostatic Discharge	EN61000-4-2 compliant							
	Radiated, Radio-Frequency EM Field	EN61000-4-3 compliant							
	Fast Transient Burst	EN61000-4-4 compliant							
	Lightning Surge	EN61000-4-5 compliant							
	RF Conducted Immunity	EN61000-4-6 compliant							
	Magnetic Field Immunity	EN61000-4-8 compliant							
	Voltage Dip / Regulation	EN61000-4-11 compliant							
	Conducted Emission	VCCI-A, FCC-A, EN55022-A compliant *Characteristic data: Fig.7 and 8						Measured by single unit	
	Harmonic Current Regulation	Choke coils can be mounted optionally to limit harmonic current							
Others	Safety Standard	UL, CSA (c-UL), EN compliant							
	Cooling System	Forced air cooling							
	Output Grounding	Connected to chassis (FG)							
	Output Hold-up Time	*Characteristic data: Fig.13							
	Reliability Grade	HOA						Follow our standard	
	MTBF	100,000H min.						Based on EIAJ RCR-9102	
	Weight	1.6kg typ.							
Warranty	1 years after delivery. If any faults belong to us, the defective unit shall be repaired or replaced at our cost.						Except for errors caused by operation not listed		

BRAIN Power Supply

Desktop PC Power Supply

Nonstop (Uninterruptible / No Power-interruption) Power Supply

Fig.1 Output power Cross Regulation

Follow the graph below for the power distribution of the total power of +3.3V and +5V vs. +12V output power.

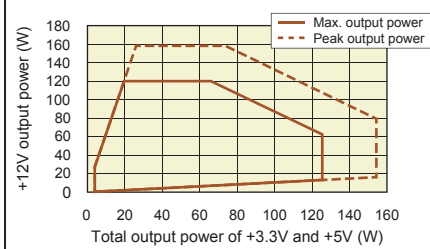
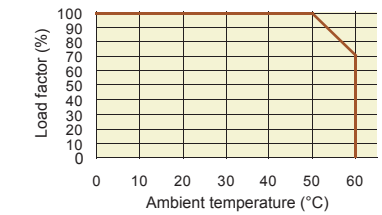

Fig.2 Temperature Derating

When the ambient temperature (near the airflow inlet) exceeds 50°C, follow the derating curve to derate rated current/power, max. current/power, and peak current/power.



# Signal Input / Output Specification Condition: at normal temperature and humidity unless otherwise specified

\*Only for aNSP3-250-S20. Refer to [ ] only for aNSP3-250-S21.

	Items	Specification	Note
Input Signal	Output ON / OFF Control Signal (PS_ON#)	+3.3V, +5V, +12V, -5V and -12V outputs shutdown with 'H' or 'OPEN' input. (During the backup operation, battery connection is shut off with 'H' or 'OPEN' input.)	Signal input between the pin 14 [pin 16] of P1 connector and COM pin
	+3.3V SENSE	The input terminal to detect the voltage of +3.3V output; by connecting to the load terminal, only the line drop of the + side of the output cable is compensated.	The pin 11 [pin 13] of P1 connector
	Battery Shutdown Signal for TTL* (SHUT_DOWN_T)	Battery connection is shutdown with 'L' input. (available only during the backup operation)	Signal input between the pin 2 of P12 connector and COM pin
	Battery Shutdown Signal for RS232C (SHUT_DOWN_R)	Battery connection is shutdown with 'positive (+2.4V min.)' input. (available only during the backup operation)	The pin 4 of front panel RS232C connector
Output Signal	Normal Output Signal (PWR_OK)	'H' signal is delivered when the +5V output is normal (detection delay time: 200 - 350ms).	The pin 8 of P1 connector
	Blackout Detection Signal for TTL* (AC_FAIL_T)	The signal goes 'OPEN' at low AC input voltage and blackout detection (open collector output). (detection voltage: 80 VAC typ., detection delay time: 20 - 50ms)	The pin 3 of P12 connector
	Blackout Detection Signal for RS232C (AC_FAIL_R)	'Negative (-9V typ.)' is delivered at low AC input voltage and blackout detection. (detection voltage: 80 VAC typ., detection delay time: 20 - 50ms)	The pin 8 of front panel RS232C connector
	Low Battery Voltage Signal for TTL* (BATT_LOW_T)	The signal goes 'OPEN' when the battery terminal voltage decreases to 19.3V typ (open collector output). 'L' is delivered when the battery package is not connected.	The pin 4 of P12 connector
	Low Battery Voltage Signal for RS232C (BATT_LOW_R)	'Negative (-9V typ.)' is delivered when the battery terminal voltage decreases to 19.3V typ. ('positive (+9V typ.)' is delivered when the battery package is not connected)	The pin 1 of front panel RS232C connector
	Fan Alarm Signal* (FAN_ALARM)	When the fan works normal, 'L' signal is delivered. When the fan lock status continues, the signal goes 'OPEN' (open collector).	The pin 6 of P12 connector

## Signal Circuit

	(PS_ON#), (SHUT_DOWN_T)*	(SHUT_DOWN_R)
Input Signal Circuit		
Output Signal Circuit	<p>(PWR_OK)</p>	<p>(AC_FAIL_T)*, (FAN_ALARM), (BATT_LOW_T)*</p>
		<p>(AC_FAIL_R), (BATT_LOW_R)</p>

## Internal Structure

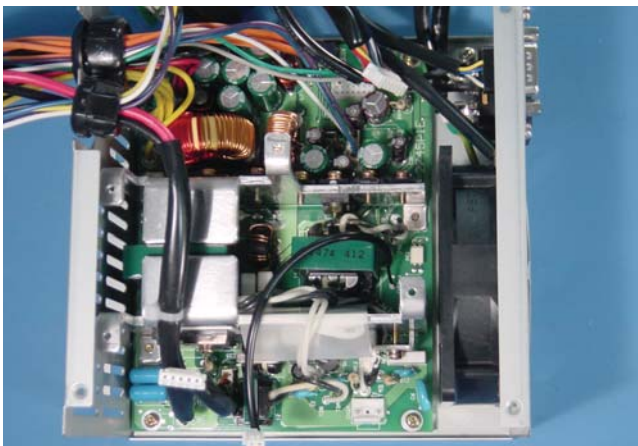

# Sequence Diagram aNSP3-250P-S20 connected w/ dedicated battery package

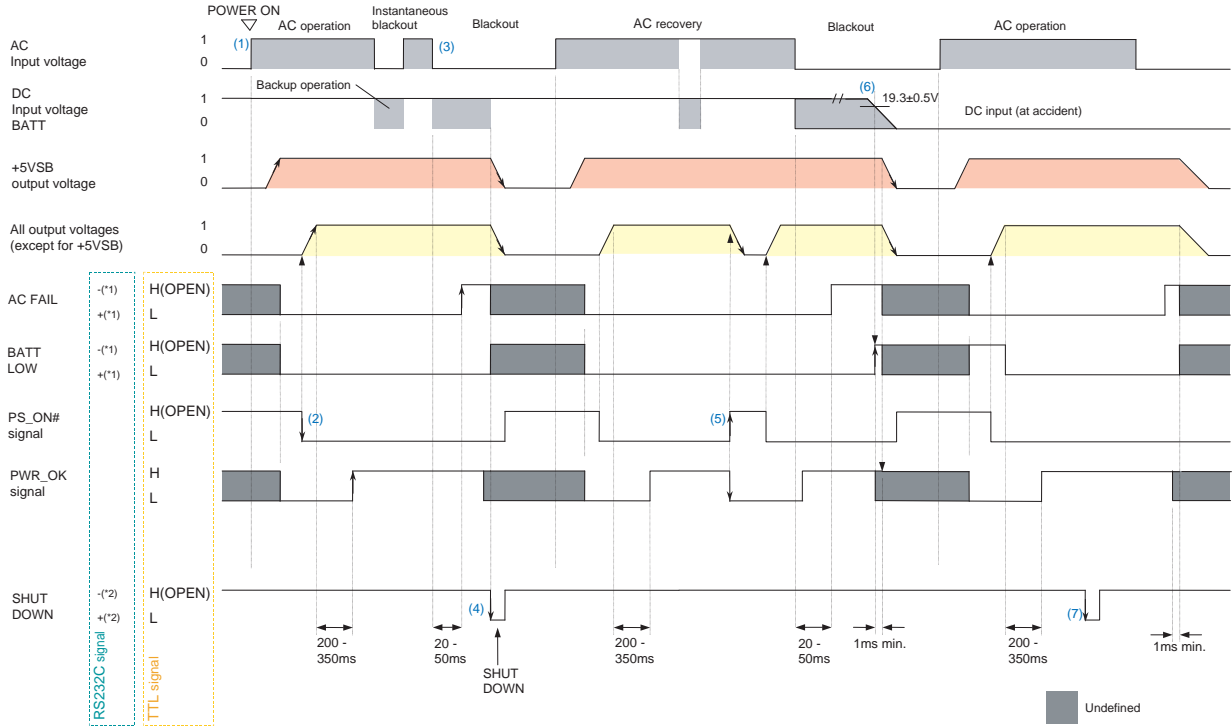

- (\*)1 Negative signal output is -9V typ. Positive signal output is +9V typ.
- (\*)2 Negative signal input should be +0.4V to -20V. Positive signal output should be +2.8V to +20V.
- (1) With AC input, only +5VSB starts up.
- (2) With PS\_ON# 'L' input, all outputs start up. After 200 - 350ms, PWR\_OK goes 'H'.
- (3) AC FAIL 'negative(RS232C)' and 'H (OPEN)(TTL)' are delivered 20 - 50ms after blackout.
- (4) At blackout, all outputs including +5VSB output shut down with SHUT DOWN 'positive (RS232C)' or 'L(TTL)' input.
- (5) When AC input and all outputs including +5VSB are turned on, all outputs except for +5VSB shutdown with PS\_ON# 'H' (OPEN) input.
- (6) When the battery voltage decreases to 19.3±0.5V typ. at backup operation, BATT LOW 'negative (RS232C)' and 'H (OPEN)(TTL)' are delivered; after it decreases to 17±0.5V typ., all outputs, including +5VSB shutdown.
- (7) At AC input, the output does not change even SHUT DOWN 'positive (RS232C)' or 'L (TTL)' is input.

# Block Diagram

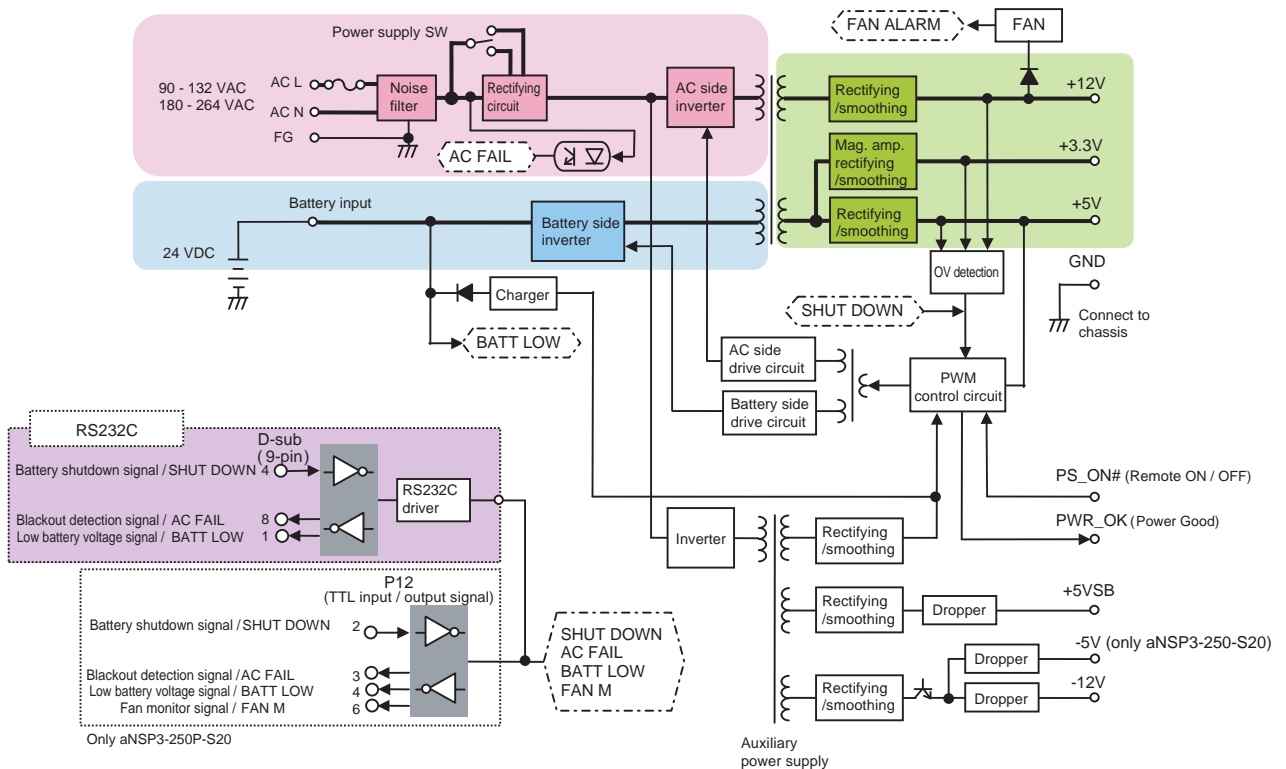

BRAIN Power Supply  
Desktop PC Power Supply  
Nonstop (Uninterruptible / No Power-interruption) Power Supply

# Outline Drawing / Output Harness

## aNSP3-250P-S20

Mounting hole details

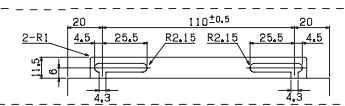

CH NAME	PIN No.	FUNCTION	WIRE COLOR	WIRE TYPE	CONNECTOR TYPE
P1	1	+3.3VDC	ORANGE	UL1007	Housing:CP-01120030(CvLux) Terminal:CP-01100102(CvLux) or equivalent
	2	+3.3VDC	ORANGE	AWG#18	
	3	COM	BLACK	AWG#18	
	4	+5VDC	RED	AWG#18	
	5	COM	BLACK	AWG#18	
	6	+5VDC	RED	AWG#18	
	7	COM	BLACK	AWG#18	
	8	PWR-OK	GRAY	AWG#22	
	9	+5V SB	PURPLE	AWG#18	
	10	+12VDC	YELLOW	AWG#18	
P2	1	+3.3VDC	ORANGE	AWG#22	Housing:CP-01100105(CvLux) Terminal:CP-01100105(CvLux) or equivalent
	2	+3.3VDC	ORANGE	AWG#18	
	3	COM	BLACK	AWG#18	
	4	+5VDC	RED	AWG#22	
	5	COM	BLACK	AWG#18	
	6	+5VDC	RED	AWG#18	
	7	COM	BLACK	AWG#18	
	8	+5VDC	RED	AWG#18	
	9	COM	BLACK	AWG#18	
	10	+5VDC	RED	AWG#18	
P4-8	1	+12VDC	YELLOW	AWG#18	Housing:CP-0114030(CvLux) Contact:CP-010002(CvLux) or equivalent
	2	COM	BLACK	AWG#18	
	3	+12VDC	YELLOW	AWG#18	
	4	COM	BLACK	AWG#18	
P9	1	+5VDC	RED	AWG#18	Housing:LCP-04(JST) Terminal:SLC22T-2,0(JST) or equivalent
	2	COM	BLACK	AWG#18	
	3	+5VDC	RED	AWG#18	
	4	COM	BLACK	AWG#18	
P12	1	+5VDC	RED	AWG#22	Housing:5200-063(molex) Terminal:170204-1(AMP) or equivalent
	2	COM	BLACK	AWG#18	
	3	+5VDC	RED	AWG#22	
	4	COM	BLACK	AWG#18	
BATT	1	BATT +VE	RED	AWG#14	Housing:VLR-03V(JST) Terminal:SVH-61T-P20(JST) or equivalent
	2	BATT -VE	BLACK	AWG#14	

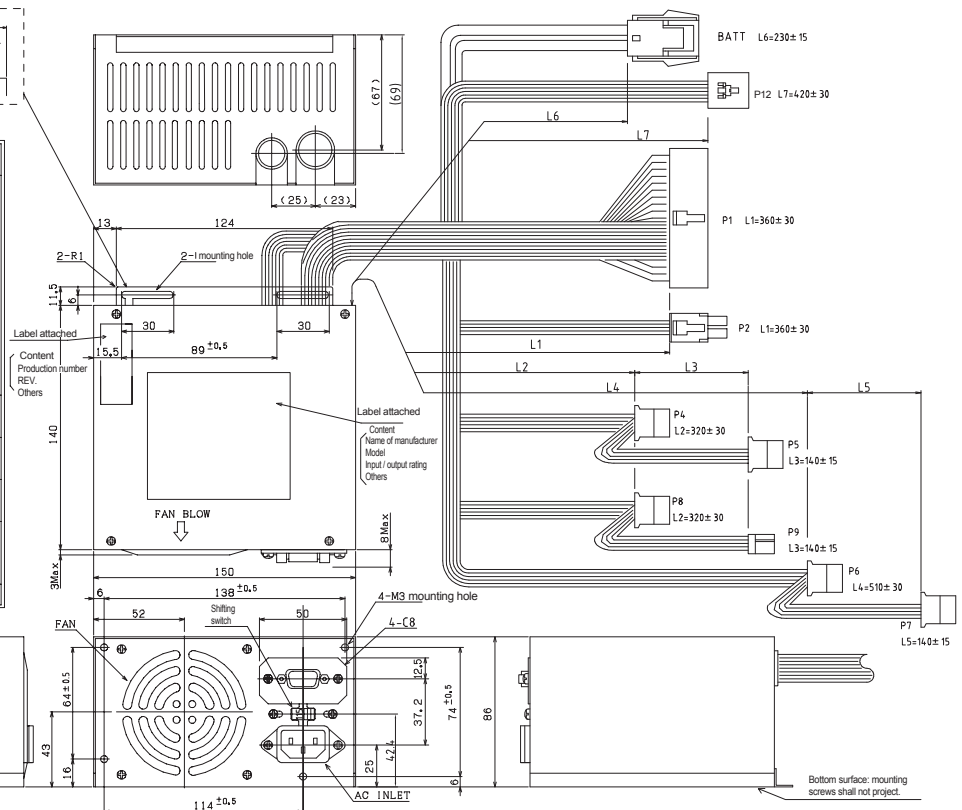

■ Installation direction  
The unit can be installed in any directions.

## aNSP3-250P-S21

Mounting hole details

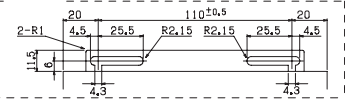

CH NAME	PIN No.	FUNCTION	WIRE COLOR	WIRE TYPE	CONNECTOR TYPE
P1	1	+3.3V	ORANGE	UL1007	Housing:CP-01124030(CvLux) Terminal:13PIN CP-01100105(CvLux) Other:CP-01100102(CvLux) or equivalent
	2	+3.3V	ORANGE	AWG#18	
	3	COM	BLACK	AWG#18	
	4	+5V	RED	AWG#18	
	5	COM	BLACK	AWG#18	
	6	+5V	RED	AWG#18	
	7	COM	BLACK	AWG#18	
	8	PWR-OK	GRAY	AWG#22	
	9	+5V SB	PURPLE	AWG#18	
	10	+12V	YELLOW	AWG#18	
P2	1	+3.3V	ORANGE	AWG#22	Housing:5551-04(R/molex) Terminal:5556(molex) or equivalent
	2	+3.3V	ORANGE	AWG#18	
	3	COM	BLACK	AWG#18	
	4	+5V	RED	AWG#22	
	5	COM	BLACK	AWG#18	
	6	+5V	RED	AWG#18	
	7	COM	BLACK	AWG#18	
	8	+5V	RED	AWG#18	
	9	COM	BLACK	AWG#18	
	10	+5V	RED	AWG#18	
P3	1	+12V	YELLOW	AWG#18	Housing:LCP-04(JST) Terminal:SLC22T-2,0(JST) or equivalent
	2	COM	BLACK	AWG#18	
	3	+12V	YELLOW	AWG#18	
	4	COM	BLACK	AWG#18	
P4	1	+12V	YELLOW	AWG#18	Housing:C94PF1A10(CvLux) Terminal:C94PF1C10(CvLux) or equivalent
	2	COM	BLACK	AWG#18	
	3	+5V	RED	AWG#18	
	4	COM	BLACK	AWG#18	
P5	1	+3.3V	ORANGE	AWG#18	Housing:C94PF1A10(CvLux) Terminal:C94PF1C10(CvLux) or equivalent
	2	+12V	YELLOW	AWG#18	
	3	+5V	RED	AWG#18	
	4	COM	BLACK	AWG#18	
P6	1	+12V	YELLOW	AWG#18	Housing:SLC22T-2,0(JST) Terminal:SLC22T-2,0(JST)
	2	COM	BLACK	AWG#18	
	3	+5V	RED	AWG#18	
	4	COM	BLACK	AWG#18	
P7	1	+12V	YELLOW	AWG#18	Housing:LCP-04(JST) Terminal:SLC22T-2,0(JST)
	2	COM	BLACK	AWG#18	
	3	+5V	RED	AWG#18	
	4	COM	BLACK	AWG#18	
P8	1	+5V	RED	AWG#22	Housing:171822-4(AMP) Terminal:170204-1(AMP) Housing:VLR-03V(JST) Terminal:SVH-61T-P20(JST)
	2	COM	BLACK	AWG#18	
	3	+5V	RED	AWG#22	
	4	COM	BLACK	AWG#18	
BATT	1	BATT +VE	RED	AWG#14	Terminal:SVH-61T-P20(JST)
	2	BATT -VE	BLACK	AWG#14	

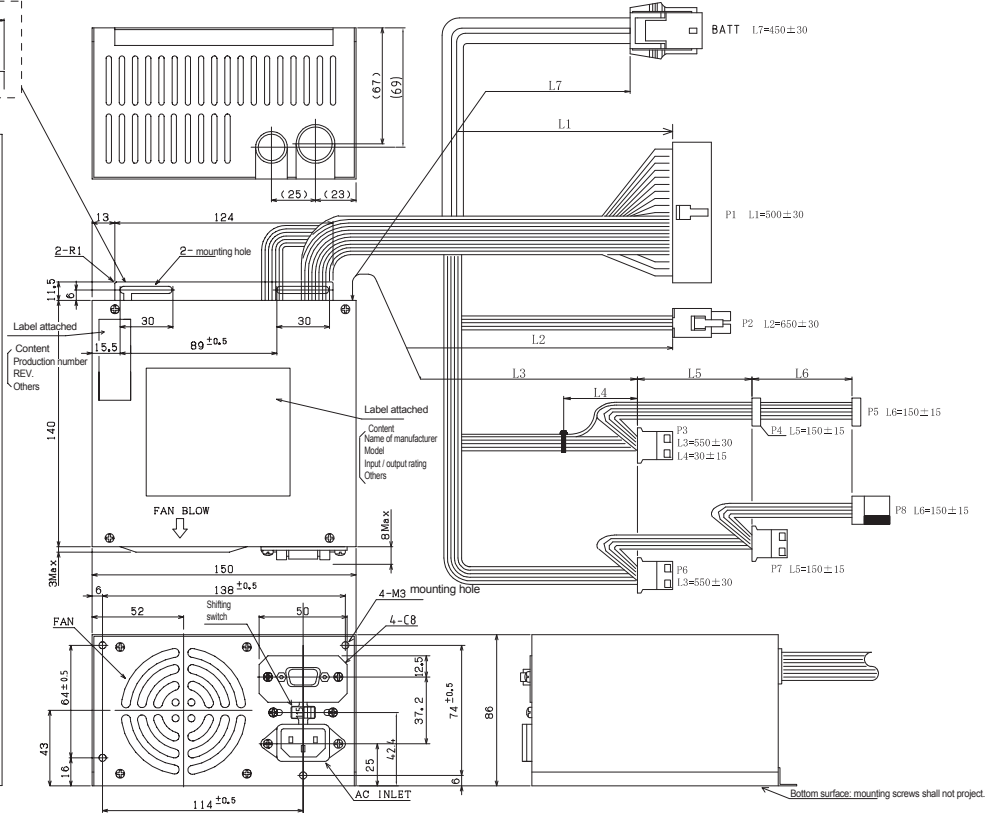





■ Installation direction  
The unit can be installed in any directions.

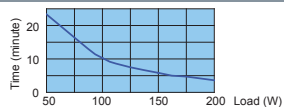

BRAIN Power Supply  
Desktop PC Power Supply

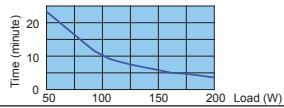
Nonstop (Uninterruptible / No Power-interruption) Power Supply

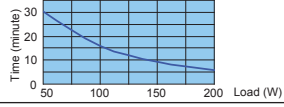

## Optional Components Sold Separately

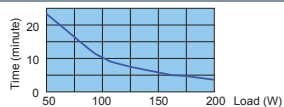
Battery Package (aNSP3-250P-S20)					
Page	Picture	Model	Type	Shape (size)	Backup Time
P.401		BS05A-P24/2.2L	Lead	5-inch bay fixed type (W×D×H=146×190×37mm)	
P.403		RBS01A-P24/2.2L	Lead	5-inch bay fixed, removable type (W×D×H=146×245×42mm)	
P.407		BS06A-H24/2.5L (for standby use) BS06B-H24/2.5L (with fan, for cycle use)	Ni-MH	5-inch bay fixed type (W×D×H=146×181×38mm)	

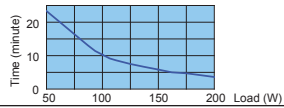
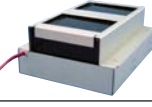
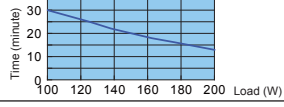
\*The backup time is a reference value at initial use; it is not a guaranteed value.

Battery Package (aNSP3-250P-S21)					
Page	Picture	Model	Type	Shape (size)	Backup Time
P.402		BS11A-P24/2.3L	Lead	5-inch bay fixed type (W×D×H=146×190×37mm)	
P.404		RBS02A-P24/2.3L	Lead	5-inch bay fixed, removable type (W×D×H=146×245×42mm)	
P.405		BS12A-P24/5.0L	Lead	5-inch bay 2 unit fixed type (W×D×H=146×190×74.9mm)	

\*The backup time is a reference value at initial use; it is not a guaranteed value.

Cable				
Picture	Model	Type	Description	
	WH2601-02	RS232C communication cable	Dedicated to Windows 2000 / XP / Vista / 7 [RoHS]	
	WH2753	AC power cord	125 VAC 12A [PSE]	
	WH2753-02	AC power cord	125 VAC 12A (tracking resistance type) [PSE]	

Software				
Picture	Model	Type	Description	
	NSP Pro 2	Automatic shutdown software	Dedicated to Windows 2000 / XP / Vista / 7	

\*Free software "NSP Pro 2" available at our web-site  
\*The UPS service of Windows 2000 and XP available

Other Optional Components				
Model	Description	Model	Description	
ACC2637	Automatic startup unit	WH5105	12V 4-pin connector conversion harness (80mm)	
WH2820	20-pin extension harness (600mm)	WH5105-02	12V 4-pin connector conversion harness (320mm)	
WH2747	20-pin extension harness (450mm)	WH5055	AT connector conversion harness	
WH2892-02	20-pin extension harness (200mm)	ACC5046	Harness with PS_ON switch	
WH2812	PCI-E 6-pin connector conversion harness	ACC5077	PS_ON terminal short connector	
		WH5073	PS_ON terminal short 20-pin harness	

BRAIN  
Power  
Supply

Desktop PC Power Supply

Nonstop (Uninterruptible / No Power-interruption) Power Supply

# Characteristics Data aNSP3-250P-S20 (Examples of actual measurement)

● Fig.3 Efficiency / Input Current vs. Output Power

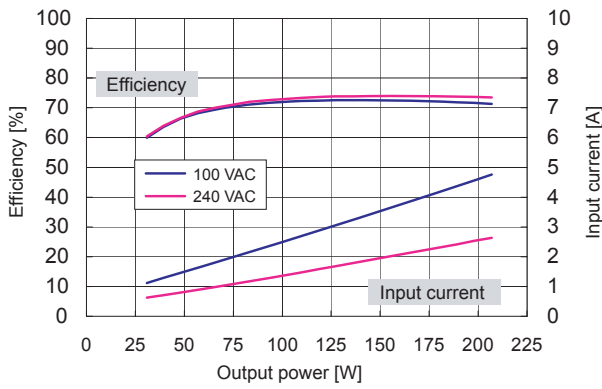

● Fig.4 Power Factor / Input VA vs. Output Power

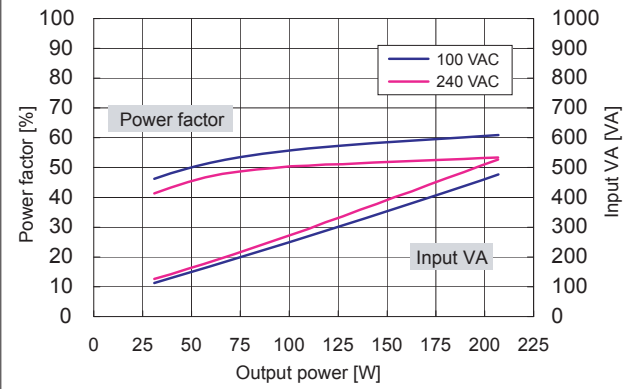

● Fig.5 Inrush Current

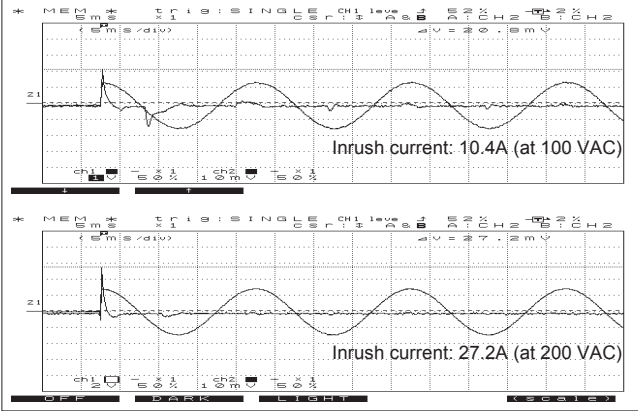

● Fig.6 Leakage Current

Input: 100 / 200 / 240 VAC  
Load: Rated and min. load

	Rated load	Min. load
100 VAC	0.36mA	0.38mA
200 VAC	0.55mA	0.58mA
240 VAC	0.66mA	0.68mA

● Fig.7 Conducted Emission at 100 VAC

Input: 100 VAC  
Load: Rated  
Mode: Peak

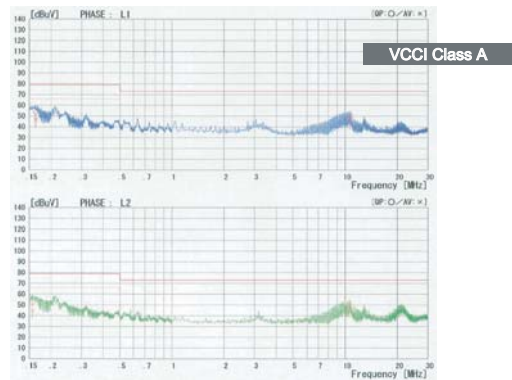

● Fig.8 Conducted Emission at 240 VAC

Input: 240 VAC  
Load: Rated  
Mode: Peak

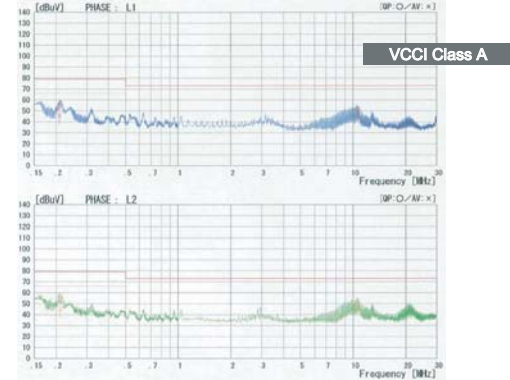

● Fig.9 Rising Characteristics at 100 VAC

Input: 100 VAC  
Load: Rated  
Time axis: 2ms/DIV

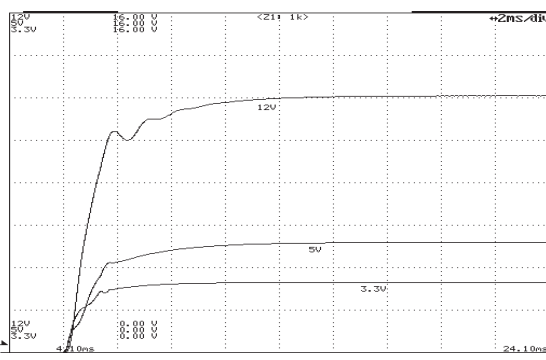

● Fig.10 Falling Characteristics at 100 VAC when REMOTE goes Off

Input: 100 VAC  
Load: Rated  
Time axis: 10ms/DIV

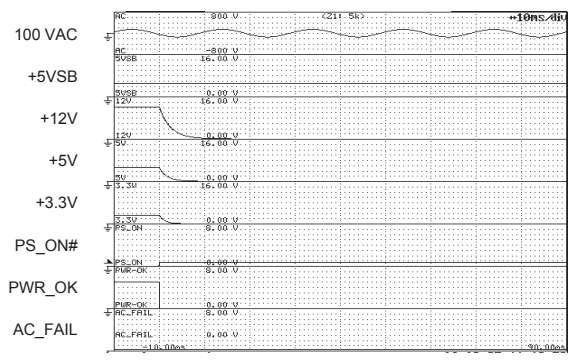

# Characteristics Data aNSP3-250P-S20 (Examples of actual measurement)

● Fig.11 Rising Characteristics at 200 VAC

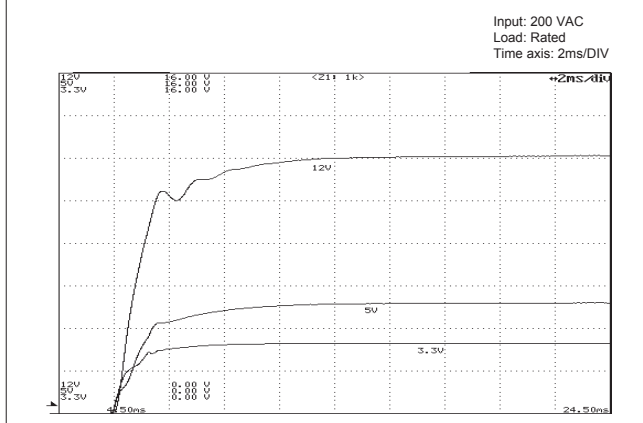

● Fig.12 Falling Characteristics at 200 VAC when REMOTE goes Off

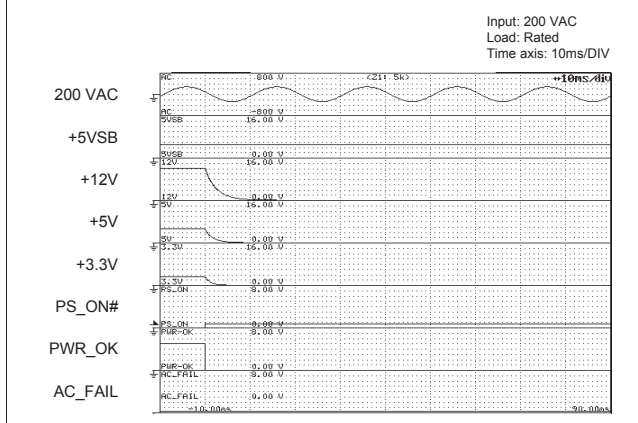

● Fig.13 Output Hold-up Time vs. Output Power

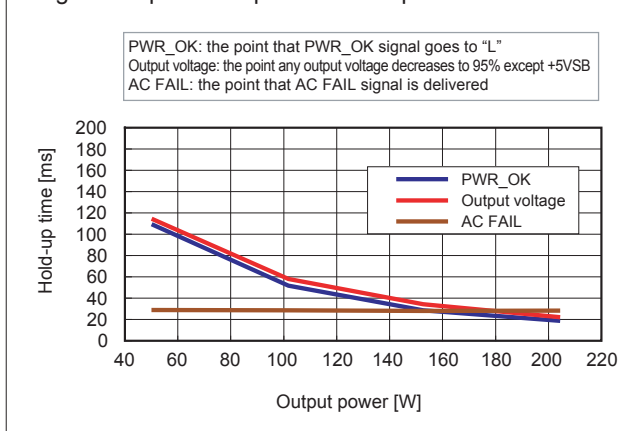

● Fig.14 Dynamic Load Fluctuation Characteristics at 1kHz

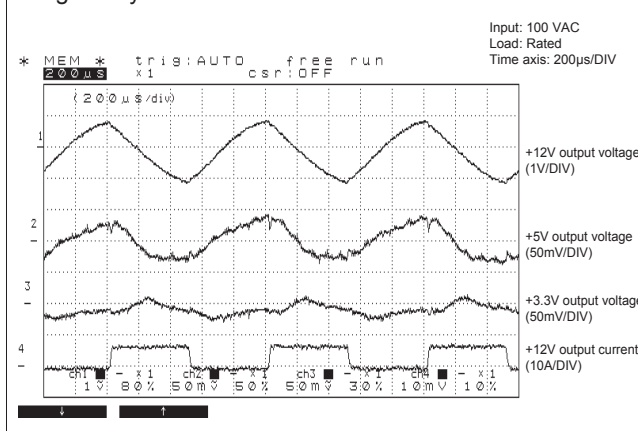

● Fig.15 Output Voltage Regulation

Output	Min. load	Rated load	Peak load
+12V output	0A	7A	13A
+5V output	2A	14A	25A
+3.3V output	0A	9.4A	20A

AC input voltage	90 VAC	100 VAC	132 VAC	180 VAC	240 VAC	264 VAC
+12V output (min. load)	12.460 V	12.661 V	13.016 V	12.406 V	12.944 V	13.017 V
+12V output (rated load)	11.765 V	11.762 V	11.746 V	11.764 V	11.748 V	11.743 V
+12V output (peak load)	11.420 V	11.370 V	11.380 V	11.390 V	11.380 V	11.380 V
+5V output (min. load)	5.095 V	5.091 V	5.084 V	5.096 V	5.086 V	5.083 V
+5V output (rated load)	5.057 V	5.058 V	5.058 V	5.058 V	5.057 V	5.057 V
+5V output (peak load)	5.020 V	4.990 V	5.000 V	5.000 V	5.000 V	5.010 V
+3.3V output (min. load)	3.349 V	3.349 V	3.350 V	3.349 V	3.350 V	3.351 V
+3.3V output (rated load)	3.295 V	3.295 V	3.297 V	3.295 V	3.297 V	3.297 V
+3.3V output (peak load)	3.230 V	3.210 V	3.230 V	3.240 V	3.230 V	3.230 V

● Fig.16 Ripple and Spike Voltage

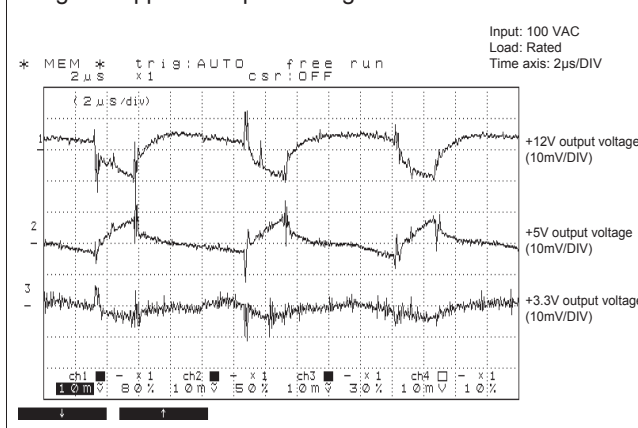

● Fig.17 Ambient Temperature vs. Expected Service Life

■ Electrolytic capacitors

Input: 100 VAC  
Load: Rated  
Operating time: 24 consecutive hours

Intake air temp.	20°C	30°C	40°C	50°C
Expected service life (yr)	approx. 24	approx. 12	approx. 6.0	approx. 3.0

※ Lifetime shall be 15 years at longest due to deterioration of sealing plates.

■ Fan

Ambient temp.	20°C	30°C	40°C	50°C
Expected service life (yr)	approx. 14	approx. 14	approx. 14	approx. 9.3

● Fig.18 Over Current Protection (V-I Characteristic)

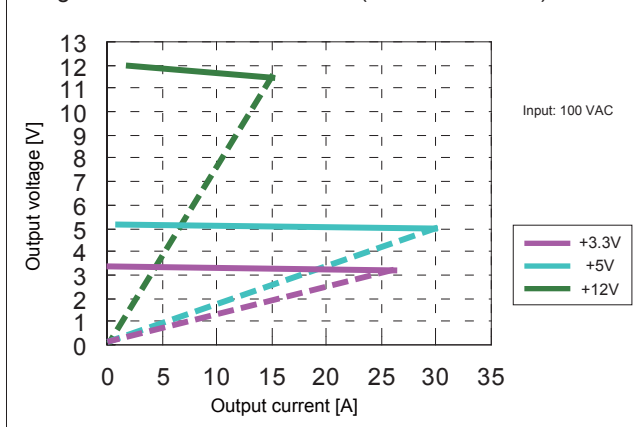

BRAIN Power Supply  
Desktop PC Power Supply  
Nonstop (Uninterruptible / No Power-interruption) Power Supply